

SONY®

DIGITAL CINEMATOGRAPHY CAMERA

F23



OPERATION MANUAL
1st Edition

English

For the customers in the U.S.A.

This equipment has been tested and found to comply with the limits for a Class A digital device, pursuant to Part 15 of the FCC Rules. These limits are designed to provide reasonable protection against harmful interference when the equipment is operated in a commercial environment. This equipment generates, uses, and can radiate radio frequency energy and, if not installed and used in accordance with the instruction manual, may cause harmful interference to radio communications. Operation of this equipment in a residential area is likely to cause harmful interference in which case the user will be required to correct the interference at his own expense.

You are cautioned that any changes or modifications not expressly approved in this manual could void your authority to operate this equipment.

All interface cables used to connect peripherals must be shielded in order to comply with the limits for a digital device pursuant to Subpart B of Part 15 of FCC Rules.

For the customers in Europe

This product with the CE marking complies with the EMC Directive issued by the Commission of the European Community.

Compliance with this directive implies conformity to the following European standards:

- EN55103-1: Electromagnetic Interference (Emission)
- EN55103-2: Electromagnetic Susceptibility (Immunity)

This product is intended for use in the following Electromagnetic Environments: E1 (residential), E2 (commercial and light industrial), E3 (urban outdoors), E4 (controlled EMC environment, ex. TV studio).

For the customers in Europe

The manufacturer of this product is Sony Corporation, 1-7-1 Konan, Minato-ku, Tokyo, Japan.

The Authorized Representative for EMC and product safety is Sony Deutschland GmbH, Hedelfinger Strasse 61, 70327 Stuttgart, Germany. For any service or guarantee matters please refer to the addresses given in separate service or guarantee documents.

Pour les clients européens

Ce produit portant la marque CE est conforme à la Directive sur la compatibilité électromagnétique (EMC) émise par la Commission de la Communauté européenne.

La conformité à cette directive implique la conformité aux normes européennes suivantes :

- EN55103-1 : Interférences électromagnétiques (émission)
- EN55103-2 : Sensibilité électromagnétique (immunité)

Ce produit est prévu pour être utilisé dans les environnements électromagnétiques suivants : E1 (résidentiel), E2 (commercial et industrie légère), E3 (urbain extérieur) et E4 (environnement EMC contrôlé, ex. studio de télévision).

Pour les clients européens

Le fabricant de ce produit est Sony Corporation, 1-7-1 Konan, Minato-ku, Tokyo, Japon.

Le représentant autorisé pour EMC et la sécurité des produits est Sony Deutschland GmbH, Hedelfinger Strasse 61, 70327 Stuttgart, Allemagne. Pour toute question concernant le service ou la garantie, veuillez consulter les adresses indiquées dans les documents de service ou de garantie séparés.

Für Kunden in Europa

Dieses Produkt besitzt die CE-Kennzeichnung und erfüllt die EMV-Richtlinie der EG-Kommission.

Angewandte Normen:

- EN55103-1: Elektromagnetische Verträglichkeit (Störaussendung)
- EN55103-2: Elektromagnetische Verträglichkeit (Störfestigkeit), für die folgenden elektromagnetischen Umgebungen: E1 (Wohnbereich), E2 (kommerzieller und in beschränktem Maße industrieller Bereich), E3 (Stadtbereich im Freien) und E4 (kontrollierter EMV-Bereich, z.B. Fernsehstudio).

Für Kunden in Europa

Der Hersteller dieses Produkts ist Sony Corporation, 1-7-1 Konan, Minato-ku, Tokyo, Japan.

Der autorisierte Repräsentant für EMV und Produktsicherheit ist Sony Deutschland GmbH, Hedelfinger Strasse 61, 70327 Stuttgart, Deutschland. Bei jeglichen Angelegenheiten in Bezug auf Kundendienst oder Garantie wenden Sie sich bitte an die in den separaten Kundendienst- oder Garantiedokumenten aufgeführten Anschriften.

For the State of California, USA only

Perchlorate Material - special handling may apply, See www.dtsc.ca.gov/hazardouswaste/perchlorate
Perchlorate Material : Lithium battery contains perchlorate.

For the customers in the USA and Canada RECYCLING LITHIUM-ION BATTERIES

Lithium-ion batteries are recyclable.

You can help preserve our environment by returning your used rechargeable batteries to the collection and recycling location nearest you.

For more information regarding recycling of rechargeable batteries, call toll free 1-800-822-8837, or visit

<http://www.rbrbc.org/>

Caution: Do not handle damaged or leaking Lithium-ion batteries.



Pour les utilisateurs aux Etats-Unis et au Canada. RECYCLAGE DES ACCUMULATEURS AUX IONS DE LITHIUM

Les accumulateurs aux ions de lithium sont recyclables. Vous pouvez contribuer à préserver l'environnement en rapportant les piles usées dans un point de collection et recyclage le plus proche.

Pour plus d'informations sur le recyclage des accumulateurs, téléphonez le numéro gratuit 1-800-822-8837 (Etats-Unis et Canada uniquement), ou visitez <http://www.rbrbc.org/>

Avertissement: Ne pas utiliser des accumulateurs aux ions de lithium qui sont endommagés ou qui fuient.



Für Kunden in Deutschland

Entsorgungshinweis: Bitte werfen Sie nur entladene Batterien in die Sammelboxen beim Handel oder den Kommunen.

Entladen sind Batterien in der Regel dann, wenn das Gerät abschaltet und signalisiert „Batterie leer“ oder nach längerer Gebrauchsdauer der Batterien „nicht mehr einwandfrei funktioniert“. Um sicherzugehen, kleben Sie die Batteriepole z.B. mit einem Klebestreifen ab oder geben Sie die Batterien einzeln in einen Plastikbeutel.

Voor de Klanten in Nederland

- Gooi de batterij niet weg maar lever deze in als klein chemisch afval (KCA).
- Dit apparaat bevat een vast ingebouwde batterij die niet vervangen hoeft te worden tijdens de levensduur van het apparaat.
- Raadpleeg uw leverancier indien de batterij toch vervangen moet worden. De batterij mag alleen vervangen worden door vakbekwaam servicepersoneel.
- Lever het apparaat aan het einde van de levensduur in voor recycling, de batterij zal dan op correcte wijze verwerkt worden.

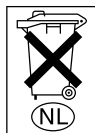

For the customers in Taiwan only



廢電池請回收

Table of Contents

Chapter 1 Overview

1-1 Features	7
1-2 Example of System Configuration	9
1-3 Locations and Functions of Parts	10
1-3-1 Camera Head	10
1-3-2 Assistant Panel (Supplied)	15
1-3-3 Interface Box (Supplied)	15

Chapter 2 Installation and Preparations

2-1 Mounting the Interface Box	17
2-2 Mounting the SRW-1 Recorder	19
2-3 Attaching a Lens	20
2-4 Attaching a Viewfinder	21
2-5 Mounting the Camera to a Tripod	22
2-6 Attaching/Detaching Handles	23
2-6-1 L Handle	23
2-6-2 Center Handle (Supplied)	23
2-7 Preparing the Power Supply	24
2-8 Setting the Built-in Clock	25

Chapter 3 Basic Adjustments and Settings

3-1 Selection of the Basic Operation Modes	26
3-1-1 Overview of the Basic Operation Modes	26
3-1-2 Switching of the Basic Operation Modes	26
3-2 Basic Settings with the Subdisplay	27
3-2-1 Basic Operation of the Subdisplay	27
3-2-2 Shutter Settings	28
3-2-3 Selection of Video Formats	30
3-2-4 Selection of the Filters	30
3-2-5 Selection of the Gain, Color Temperature, and White Balance Memory	31
3-2-6 Selection of a Lens File	31
3-2-7 Confirmation of the Time Code and Tape Remaining ..	32
3-2-8 Confirmation of the Power Voltage and Selection of Fan Operation Mode	32

3-2-9 ON/OFF of the Character Indication	32
3-2-10 Allocation of Functions to the Assignable Buttons and Switch	33
3-2-11 Brightness Adjustment of the Subdisplay	33
3-3 Black Balance Adjustment	34
3-4 White Balance Adjustment (in Custom mode)	34
3-5 Setting the Camera Outputs	36
3-5-1 Selecting a Video Output Signal for Each Connector	36
3-5-2 Setting the Monitor Picture	36
3-5-3 Outputting Color Bars	38
3-6 Viewing and Setting the Viewfinder Displays	39
3-6-1 Viewing the Basic Status Indications	39
3-6-2 Viewing the ABNORMAL <!> Display	40
3-6-3 Viewing the FUNCTION (Format/Switch Function) Display	41
3-6-4 Setting the Marker Indications	41
3-6-5 Adjusting the Viewfinder Details	42
3-6-6 Setting the Zebra Indication	42
3-6-7 Setting the Cursor Indication	43
3-6-8 Checking the Power Voltage	43
3-7 Detailed Settings of the Switch Functions	44
3-8 Setting the Gain	45
3-9 Detailed Shutter Settings	45
3-10 Resuming the Standard Conditions	46
3-11 Selecting the Gamma	47
3-11-1 Using the Standard Gamma	47
3-11-2 Using the Hyper Gamma	47
3-11-3 Using the User Gamma	47
3-12 Setting the Fan Operation Mode	48
3-13 Inverting the Camera Picture	49
3-14 Detailed Setting of the Video Format	49

Chapter 4 Menu Configuration and Detailed Settings

4-1 Menu Configuration	51
4-2 Basic Menu Operations	52
4-2-1 Displaying Setting Pages	53
4-2-2 Setting the Menu Items	54
4-3 Menu List	55
4-3-1 OPERATION Menu	55
4-3-2 PAINT Menu	60
4-3-3 MAINTENANCE Menu	65
4-3-4 NETWORK Menu	70
4-3-5 FILE Menu	71

4-3-6 DIAGNOSIS Menu	74
4-4 Editing the USER Menu	75

Chapter 5 Storage and Retrieval of User Setting Data

5-1 File Configuration	78
5-2 List of Items Stored in Files	79
5-3 File Operations	81
5-3-1 Using a “Memory Stick”	81
5-3-2 Storage and Retrieval of the Operator File	82
5-3-3 Registration and Retrieval of the Lens Files	82
5-3-4 Storage and Retrieval of the Scene Files	83
5-3-5 Storage and Retrieval of the Reference File	84
5-3-6 Reading of the User Gamma	84
5-3-7 Storage of the OHB File	84
5-3-8 Resetting to the Initial Settings	85

Appendixes

Using the RM-B750	87
Connection	87
Operating the Menu of This Camera	87
Monitoring the Camera Image	88
Using the MSU-900/950	88
Connections	88
Parameter Settings	89
Warning/Error Messages	91
Precautions	92
About a “Memory Stick”	93
Specifications	95
Camera Head	95
Interface Box (Supplied)	97
Optional Accessories	97
Index	98

1-1 Features

The F23 is a digital cinematography camera equipped with 2/3-inch type CCDs, each with an effective pixel count of 1920 (H) × 1080 (V).

The camera is incorporated with newly developed imagers and a digital signal-processing LSI that yield images of a high quality for cinematic, commercial, and dramatic production applications. The camera also supports the features of a “production camera” up to details in its shape, button and indicator layout, and materials of the parts.

Superior Picture Quality and High Performance

Wide dynamic range and high-quality digital pictures

With its newly developed 2/3-type Progressive IT CCDs for 2,200,000 pixels, 14-bit A/D converter, and unique digital LSI, the camera achieves significant extension of the dynamic range and picture quality of optimal grade.

RGB 4:4:4 image capturing

The RGB 4:4:4 image-capturing capability, having high affinity with computer graphics, yields significant results, especially in chroma-keying and color-correction processes where highly exacting special-effects sequences and elaborate finishes are required in demanding movie-making, commercial, and television applications.

Variable-speed recording

When used with a Sony SRW-1 HD Portable Digital Recorder, the number of frames per second (fps) for shooting/recording is selectable in single-frame increments. This allows users to create slow- or fast-motion effects equivalent to those obtained by “overcranking” or “undercranking” a cinematic film camera.

Frame-rate settings for this function are variable from 1 to 60 fps in YCbCr signal mode and from 1 to 30 fps in RGB 4:4:4 signal mode.

Multiple frame formats

The camera covers the 1080 formats of different types to allow it to be used for high-end content creation, including commercial and broadcasting program production as well as movie making.

- Progressive mode: 1080/23.98P, 1080/24P, 1080/25P, 1080/29.97P, 1080/50P, 1080/59.94P
- Interlace mode: 1080/50i, 1080/59.94i

Imaging characteristics with wide color space

A newly developed optical prism system having wide spectral characteristics allows the camera to capture images in natural-looking colors closer to those of the actual scene than with conventional cameras.

User Gamma

As with Sony’s HDC-F950 video camera and HDW-F900R digital recorder, the F23 allows you to customize gamma curves according to your creative needs, using the CvpFileEditor¹⁾ application software.

- 1) You can download the software from the “eCSite,” the site for downloading business and professional software from Sony Corporation.

Design and Shape

New compact design

For a high level of mobility in consideration of various shooting situations, such as inside a car, the camera is housed in as compact a body as possible. In addition, buttons and indicators are laid out to provide a familiar and intuitive user interface to users of conventional cinema film cameras.

Dockable system of the SRW-1 HD Portable Digital Recorder

A dockable interface system is employed to conform to versatile shooting conditions and on-site demands. The SRW-1¹⁾ can be docked directly on the top or rear of the camera, as required for shooting conditions. The camera and SRW-1 recorder can also be tethered via cables to take advantage of the compactness of the camera for higher mobility.

- 1) The firmware of the SRW-1 may be required to be updated for use with the camera. For details, consult your local Sony representative.

Rugged and reliable lens mount

The newly designed lens mount utilizes a rigid, highly temperature-stable material, to better withstand frequent lens changes, dramatically reducing any galling of the lens mount and drift of back focus.

Compatible with film-camera accessories

The F23 is designed to be compatible with a variety of film-camera accessories, giving users a broad array of choices. These include ARRIFLEX-made bridge plates, matte boxes, follow focus units, lens focus/zoom/iris servo control units, and more. These film-camera accessories can be attached to the F23 without modification, enabling users who principally work with film to fully utilize their assets.

Having one 12 V DC output connector and another 24 V DC¹⁾ output connector, the F23 can supply power to such compatible accessories attached to it through these connectors.

1) To feed 24 V DC power in synchronization with the power switch of the camera, an independent power supply of 24V DC is required in addition to the 12 V power.

Assignable switches

Functions frequently used in the field, such as optical filter switching, can be assigned to three push buttons and one switch located on the side panel of the camera, allowing the operator to make rapid changes when working in the field.

Saving/retrieving settings with a “Memory Stick”¹⁾

Using a “Memory Stick,” you can save menu settings for particular shooting conditions for retrieval when required.

1) Memory Stick and  MEMORY STICK[™] are trademarks of Sony Corporation.

Operational Versatility

Two operation modes: Cine and Custom

The F23 offers two operation modes; “Cine Mode” for movie-making applications, where image tone is normally adjusted in post production, and “Custom Mode,” which is suitable for users who wish to fine-tune camera parameters to produce their desired look in on-set grading.

Shutter control

When using the electronic shutter, the setting indication can be switched between the shutter angle and shutter frequency.

Monitor output selection

For monitor outputs, the user can select flexibly whether to mix character information and markers, whether to apply alternative monitor gamma other than that applied to the camera signal, or how to mix the playback picture.

Image inversion function

The image inversion function allows you to cancel out the image-inversion phenomena that occurs when a cine-lens converter is used.

Other Features

Assistant panel

The supplied assistant panel has an identical button and indicator layout to that of the on-camera control panel and provides intuitive remote control of the basic camera and VTR operations at hand.

Down-conversion output

The down-converter built into the camera as standard equipment enables camera pictures as well as VTR playback pictures to be monitored using a conventional SD monitor.

Twin-viewfinder operation

Two viewfinders can be attached to the F23 for simultaneous monitoring with different settings of character information and marker indications.

1-2 Example of System Configuration

The diagram below shows a system configuration example to use of this camera.

In this manual, an optional HDVF-C35W HD Electronic Viewfinder is used to instruct how to operate the unit.

For more information about the fittings, connections, or use of additional equipment and accessories, see “Chapter 2 Installation and Preparations” as well as the operation manuals for the connected equipment.

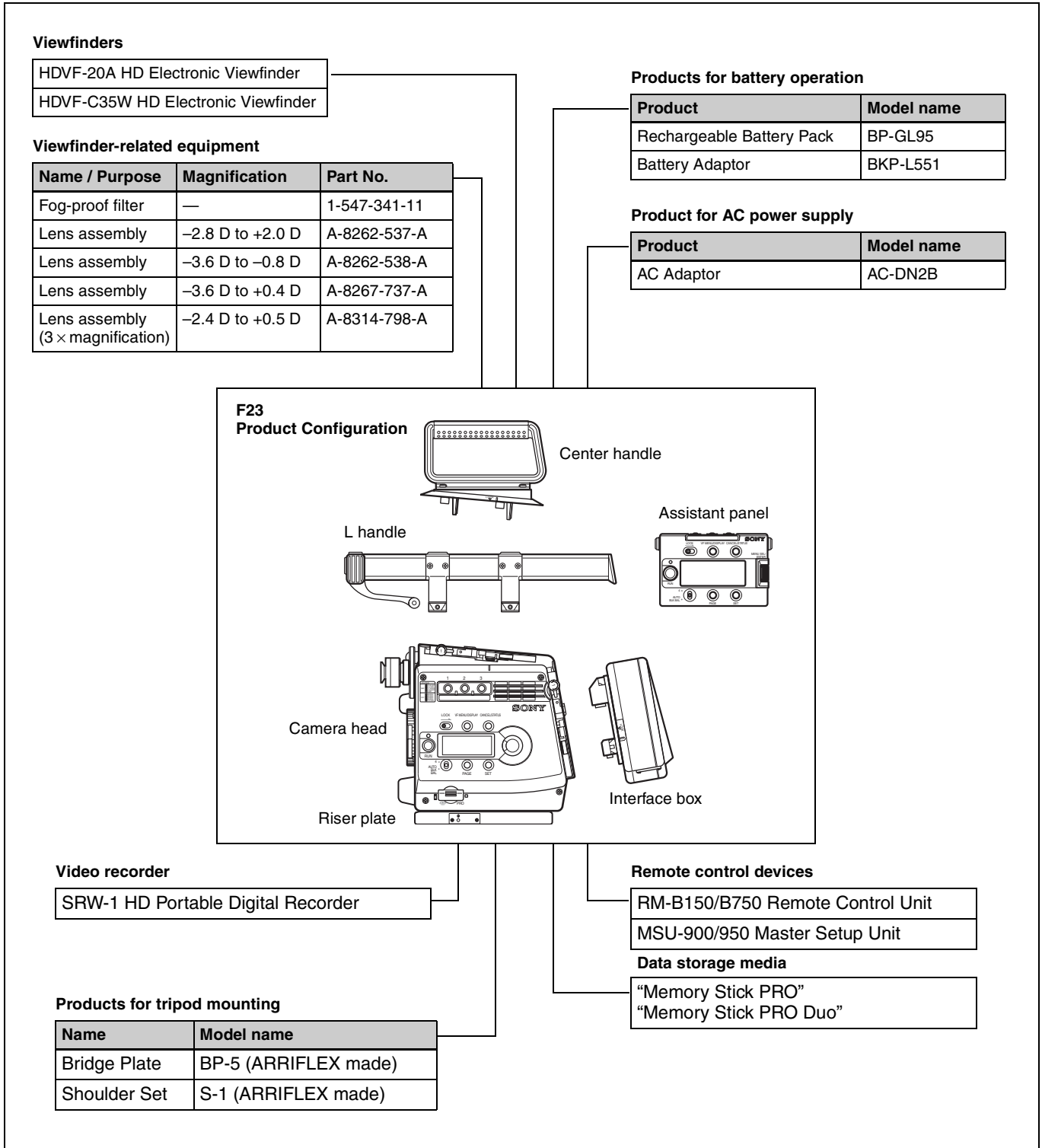

1-3 Locations and Functions of Parts

1-3-1 Camera Head

Front panel

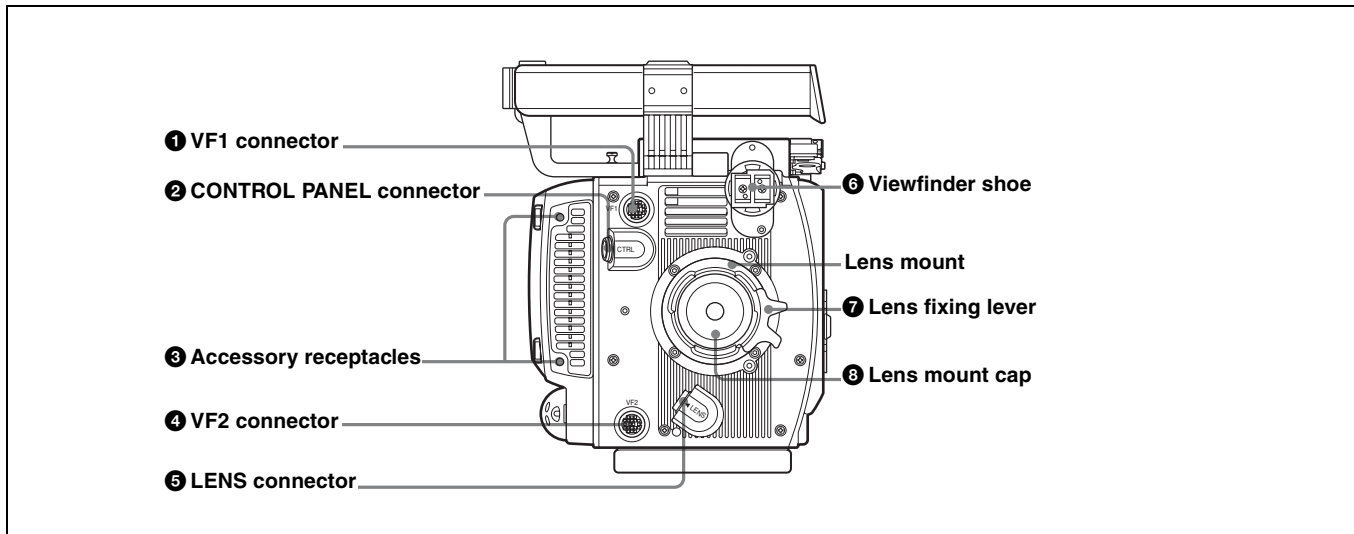

❶ VF1 (viewfinder 1) connector (20-pin)

Connect a viewfinder (optional).

❷ CONTROL PANEL connector

Connect with the CAMERA connector of the supplied assistant panel (page 15).

❸ Accessory receptacles

Using these screw holes in combination with the accessory pockets (page 11) on the left side, you can fix a certain accessory to the left side of the camera.

❹ VF2 (viewfinder 2) connector (20-pin)

Connect a second viewfinder (optional), e.g. for an assistant.

❺ LENS connector (12-pin)

If you mount an optional lens with a cable, connect the cable to this connector. You can control the functions of the lens through this connector.

❻ Viewfinder shoe

Attach an optional viewfinder.

The height of the attaching position can be adjusted.

For details, see “2-4 Attaching a Viewfinder” (page 21).

❼ Lens fixing lever

Push the lever downward to secure the lens in the lens mount. To remove the lens, pull up on the lever.

For details, see “2-3 Attaching a Lens” (page 20).

❽ Lens mount cap

Cover the lens mount with this cap when a lens is not attached. The cover may be removed by rotating the lens fixing lever upwards.

Left panel

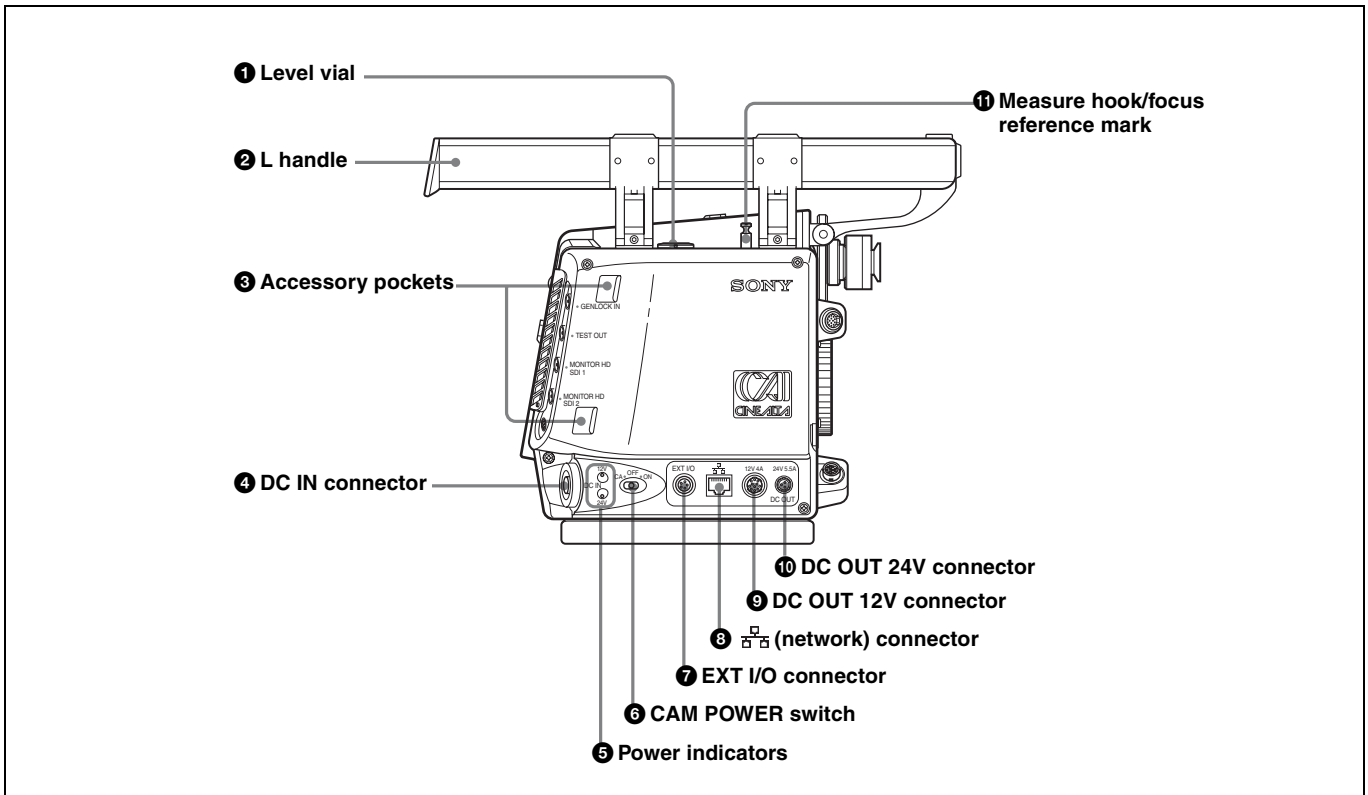

1 Level vial

Used as a reference to check that the camera stands horizontally. It can be fine-adjusted when required. If fine-adjustment is required, remove the cover and adjust it by rotating the three slotted-head screws.

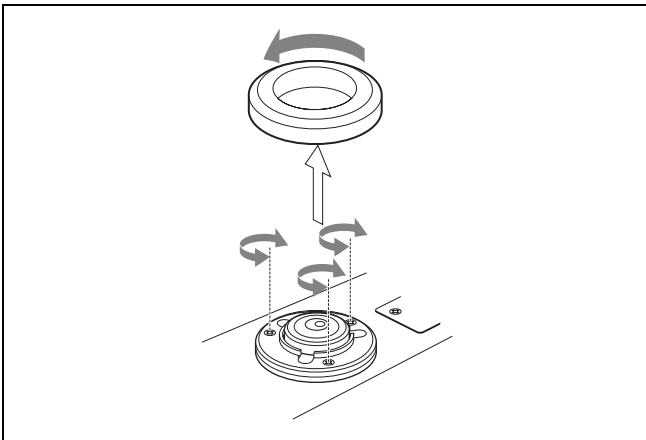

2 L handle

The L handle is attached to the top of the camera head at the factory. It has three screw holes ($\frac{3}{8}$ ") for accessories on the upper side. The assistant panel (*page 15*) can be mounted on the outside of the handle by attaching the supplied assistant panel hanger.

3 Accessory pockets

Using these accessory pockets in combination with the accessory receptacles (*page 10*) on the front panel, you can fix a certain accessory to the left side of the camera.

4 DC IN connector (LEMO 8-pin)

Power is supplied by using a specified power cord.

5 Power indicators

Either of the indicators lights according to the voltage of the power being supplied.

6 CAM POWER switch

CA: The camera is turned on using the power being supplied via the interface box (*page 15*).

OFF: The power is cut off.

ON: The camera is turned on using the power being supplied from the DC IN connector of the camera head.

Note

If you move the switch setting from ON to CA in one stroke, the power may not be cut off. To turn off the power, be sure to set the switch to the OFF position.

7 EXT I/O (external control) connector (5-pin)

For control via RS-232C.

8 Network connector (RJ-45 type, 10BASE-T, 100BASE-TX)

For control from the MSU-900/950 Master Setup Unit, etc. via a network cable.

The necessary settings are made using the NETWORK menu displayed on the viewfinder or monitor screen.

9 DC OUT 12V (DC 12V power output) connector
DC 12V power can be fed to an accessory.

10 DC OUT 24V (DC 24V power output) connector
DC 24 V power can be fed to an accessory.

Right panel

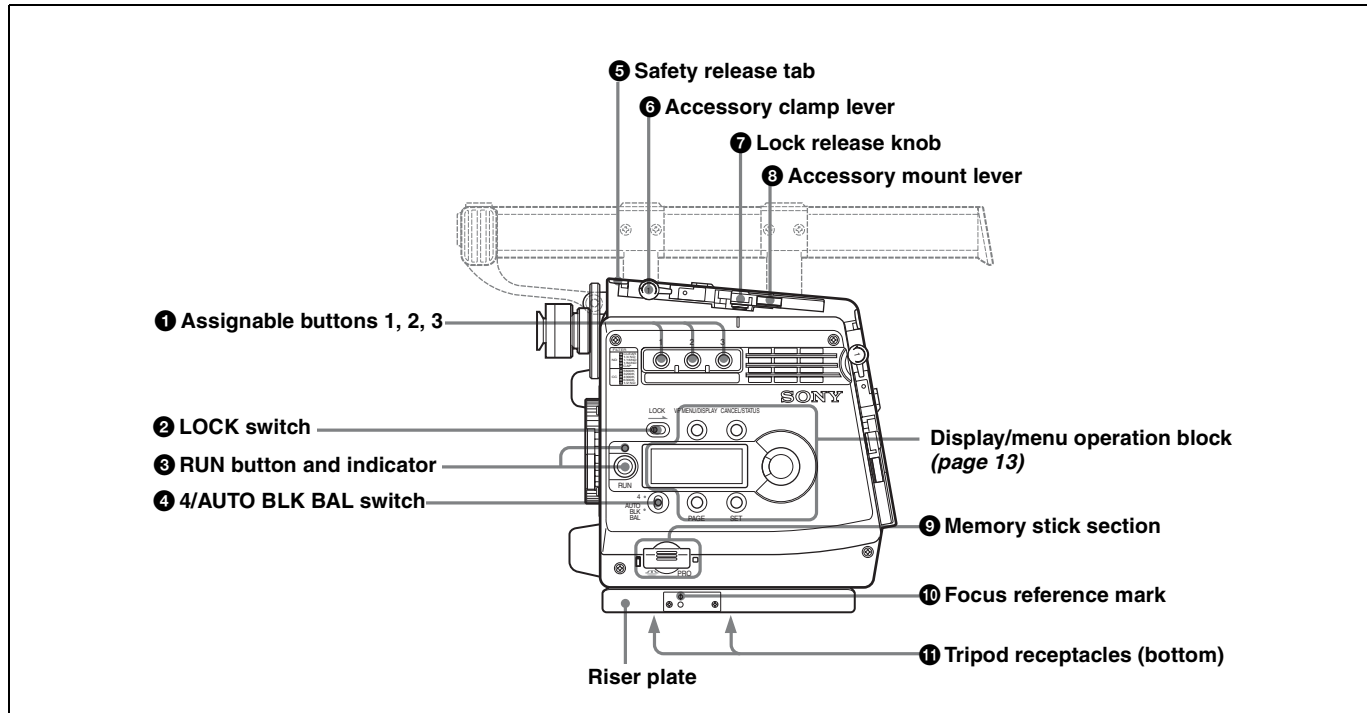

1 Assignable buttons 1, 2, 3

You can assign various functions to these buttons, using the subdisplay on the left panel or on the assistant panel or the menu displayed on the viewfinder or monitor screen. The ND filter selection function is assigned to button 1 and the CC filter selection function to button 2 at the factory. (No function is assigned to button 3.)

For details, see “3-2-10 Allocation of Functions to the Assignable Buttons and Switch” (page 33) and “3-7 Detailed Settings of the Switch Functions” (page 44).

2 LOCK switch

To disable operations on the panel.

3 RUN button and indicator

To start/stop recording on the SRW-1 HD Portable Digital Recorder docked on the camera. The indicator is lit while the recorder is in Recording mode. The indicator flashes as a warning in some cases.

For details on warning indication, see “Warning/Error Messages” (page 91).

11 Measure hook/focus reference mark

Use as reference for focusing. The same reference mark is also provided at the right of the riser plate (page 13). For actual measurement of the distance from a subject, you can fix the end of a tape measure to the hook.

The firmware of the SRW-1 may be required to be updated for use with this camera. For details, consult your local Sony representative.

4 Assignable 4/AUTO BLK BAL (auto black balance) switch

Push the switch downward to the AUTO BLK BAL side to start the auto black balance adjustment.

The function activated by pressing the switch upward to the 4 side can be selected using the subdisplay on the left panel or on the assistant panel or the menu displayed on the viewfinder or monitor screen.

For details, see “3-2-10 Allocation of Functions to the Assignable Buttons and Switch” (page 33) and “3-7 Detailed Settings of the Switch Functions” (page 44).

5 Safety release tab

6 Accessory clamp lever

7 Lock release knob

8 Accessory mount lever

For mounting/unmounting an SRW-1 HD Portable Digital Recorder or the supplied interface box to the top of the camera head.

The mounting/unmounting mechanism is the same as that on the rear panel (page 14).

For details, see “Chapter 2 Installation and Preparations”.

9 Memory Stick section

A slot to accommodate a “Memory Stick” is provided behind the rubber cap.

The access lamp is lit in red while writing or reading data to/from a “Memory Stick.”

You can use the “Memory Stick PRO” or “Memory Stick PRO Duo” with this camera. The “Memory Stick PRO Duo” media can be used without any adaptor.

Note

When the access lamp is lit in red, do not insert/remove the “Memory Stick” or turn off the camera.

For details, see “5-3-1 Using a “Memory Stick”” (page 81).

10 Focus reference mark

Used as a reference for focusing.

11 Tripod receptacles (bottom)

Two screw holes (for $\frac{3}{8}$ " camera screws) for tripod mounting are provided.

Display/menu operation block

Used to operate displays on the subdisplay and the viewfinder/monitor screen.

For details on menu operations, see “3-2-1 Basic Operation of the Subdisplay” (page 27) and “4-2 Basic Menu Operations” (page 52).

1 Subdisplay

For basic settings of this camera.

When an SRW-1 HD Portable Digital Recorder has been docked, some statuses of the recorder can also be displayed.

When the supplied assistant panel is connected, the same information will be displayed on the assistant panel.

2 VF (viewfinder) MENU/DISPLAY button

Press this button to select the display mode of the subdisplay and the viewfinder (monitor) screen.

3 CANCEL/STATUS button

In Menu Operation mode, press this button to cancel your entry or to resume the previous status.

If you press this button when the menu is not displayed on the viewfinder (monitor) screen, the status information of the camera will be displayed.

For the information displayed, see “3-6 Viewing and Setting the Viewfinder Displays” (page 39).

4 PAGE button

Press this button to flip the pages or register the setting on the subdisplay.

5 SET button

The subdisplay enters Data Change mode if you hold this button pressed for more than 1 second. Use this button also to flip to the previous page on the subdisplay.

6 MENU SEL (selection) /ENTER dial

Used to select or set the items on the subdisplay or the menu items on the viewfinder (monitor) screen.

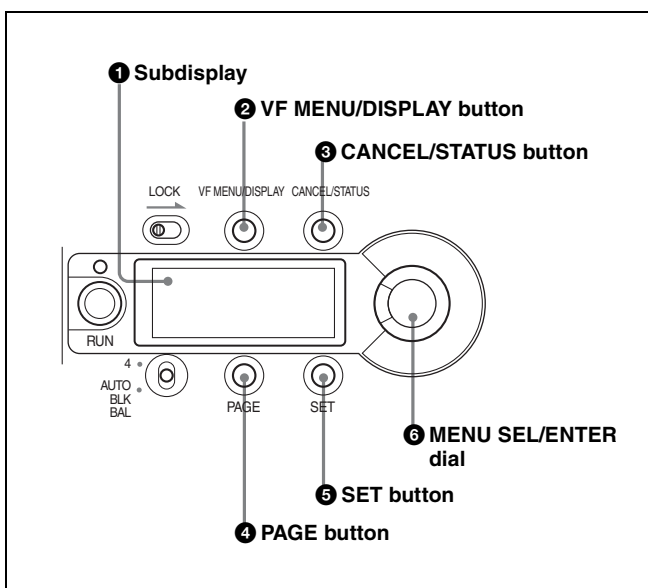

Rear panel

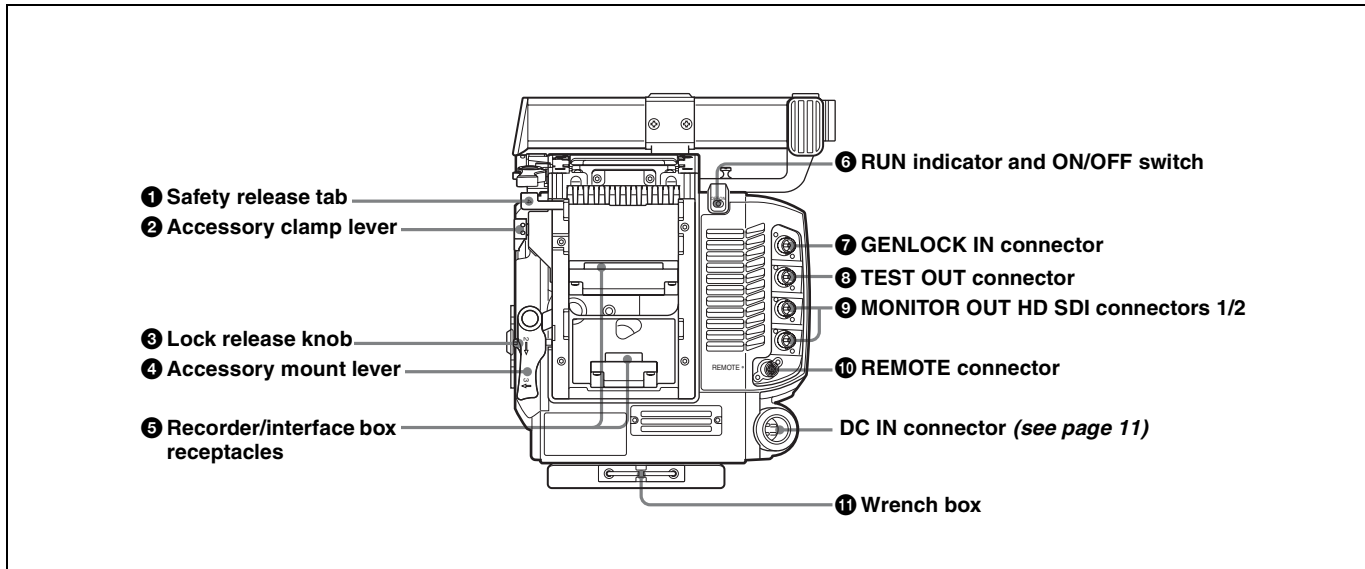

1 Safety release tab

2 Accessory clamp lever

3 Lock release knob

4 Accessory mount lever

For mounting/unmounting an SRW-1 HD Portable Digital Recorder or the interface box to/from the rear of the camera head.

The mounting/unmounting mechanism is the same as that on the top (*page 12*).

For details, see “*Chapter 2 Installation and Preparations*”.

5 Recorder/interface box receptacles

Signals and power are sent/received to/from an SRW-1 HD Portable Digital Recorder or the supplied interface box (*page 15*) mounted on the rear.

The same receptacles are provided on the top to send/receive signals and power to/from the recorder or the interface box mounted on the top.

When using a rechargeable battery

Use the receptacles on the rear panel. By attaching the BKP-L551 to the rear of the interface box, the camera can be operated on a battery. Note, however, that power will be fed only to the camera head and viewfinder. Provide another power source for the recorder.

6 RUN indicator and ON/OFF switch

When the switch is set to ON, the indicator will be lit while the recorder mounted on the camera is in Recording mode.

7 GENLOCK IN (external sync signal input) connector (BNC type)

Used for input of an external gen-lock signal (3-level sync).

8 TEST OUT connector (BNC type)

An analog test signal is fed from the connector.

The type of output signal can be set using a menu on the viewfinder or monitor screen.

9 MONITOR OUT HD SDI connectors 1/2 (BNC type)

An HD SDI signal for monitoring is fed from the connectors.

The type of output signal can be set using a menu on the viewfinder or monitor screen.

The same signal is output from connector 1 and 2.

10 REMOTE connector (8-pin)

Connect an external control device, such as the RM-B150/B750 Remote Control Unit.

11 Wrench box

A 3-mm wrench for attaching/detaching the handle and a 2.5-mm wrench for attaching/detaching the viewfinder shoe are accommodated.

1-3-2 Assistant Panel (Supplied)

The most parts are common to those on the right panel of the camera head. Connecting the panel to the CONTROL PANEL connector (page 10) of the camera head permits the camera and recorder to be operated at hand.

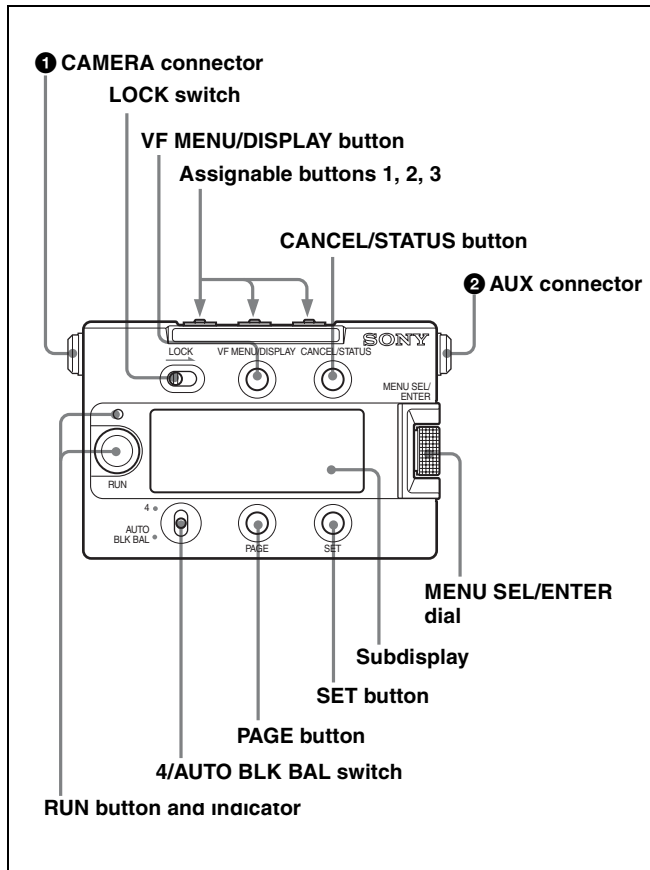

1 CAMERA connector

Using the supplied assistant panel cable, connect to the CONTROL PANEL connector of the camera head.

2 AUX (auxiliary) connector

Connect to an external device as required.

The other parts function the same as those on the right side panel of the camera head.

Note

If the assistant panel cable is disconnected/connected while you are operating the subdisplay or a menu on the viewfinder/monitor screen, the cursor/pointer on the subdisplay or on the menu page may inadvertently be moved. If a ? symbol is shown on the display, first register the setting, then disconnect/connect the cable.

1-3-3 Interface Box (Supplied)

Being attached to the top or the rear of the camera head, it transfers signals and power to/from the camera head.

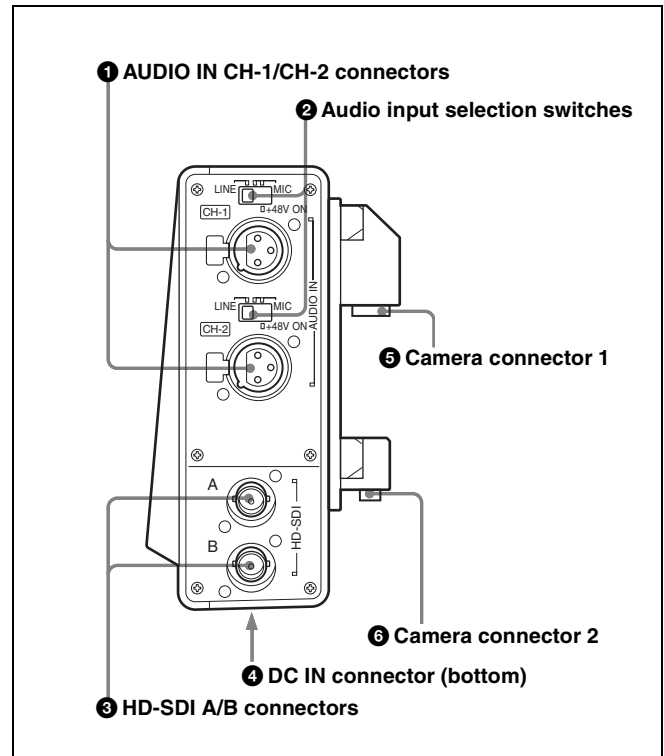

1 AUDIO IN CH-1/CH-2 connectors (XLR 3-pin, female)

Connect audio signals. Each connector is equipped with an input selection switch.

2 Audio input selection switches

Set to the appropriate position according to the equipment connected to the corresponding AUDIO IN connector.

LINE: When a line-level (0 dBm) signal source is connected

MIC: When an external microphone is connected (No power is supplied.)

+48 V ON: To supply power of +48 V to the connected microphone

3 HD-SDI A/B connectors

For Dual Link outputs of an HD-SDI signal.

4 DC IN connector (XLR 4-pin)

Connecting the BKP-L551 Battery Adaptor or a specified power cable, supply power to the interface box. The power is also fed to the camera head, viewfinder, and lens.

Note

Power is not fed to an SRW-1 recorder.



5 Camera connector 1

When the interface box is mounted on the top or rear of the camera head, video/audio and control signals are sent/received to/from the camera head.

6 Camera connector 2

When the interface box is mounted on rear of the camera head, power is sent/received to/from the camera head.

2-1 Mounting the Interface Box

The supplied interface box can be attached to the top or rear of the camera head. Connection between the camera head and the interface box is achieved by mounting, eliminating additional cable connections.

- The same attaching/detaching system is used both on the top and the rear.
- The following instructions use the illustrations of attaching to the rear as examples.
- Although the illustrations show the statuses where the L handle has been detached, the interface box can be mounted/unmounted with the L handle attached.

To attach

- 1 Place the camera head on a stable, flat surface.
- 2 Rotate the accessory clamp lever upward (toward the lens when attaching to the top).

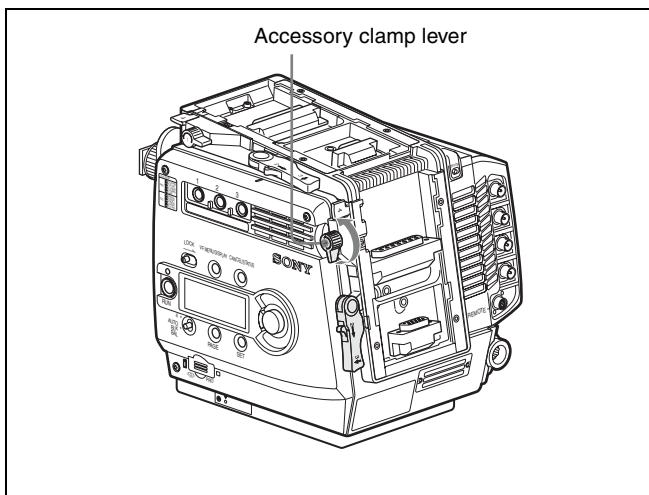

- 3 Release the lock by sliding the lock-release knob in the direction of the arrow (① in the figure below) then pull up the accessory mount lever (pull it toward the lens when mounting on the top) (② in the figure below).

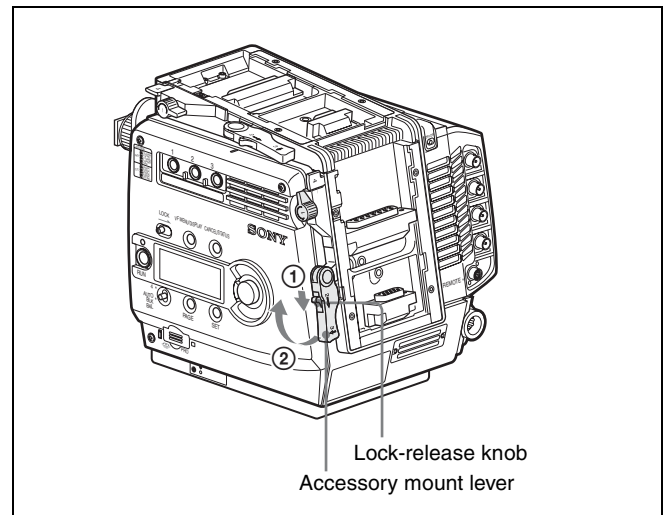

- 4 Aligning the matching line on the interface box with that on the camera head, fit the interface box into the camera head then push down on the box (slide it in the opposite direction of the lens when attaching to the top) so that the connectors engage.

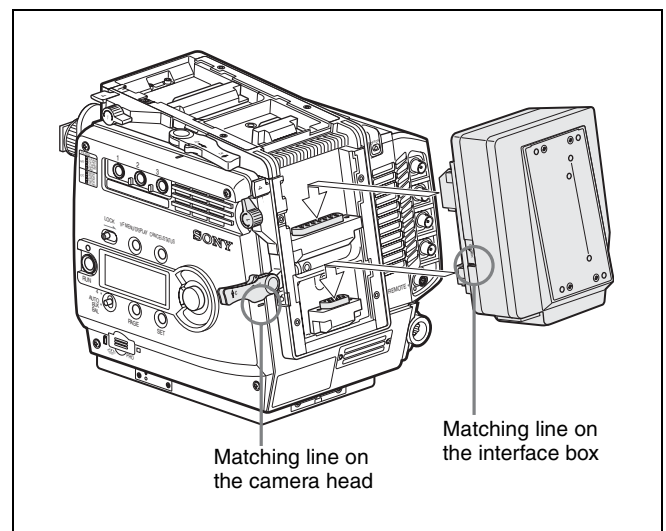

- 5** Rotate the accessory mount lever downward (pull it in the opposite direction of the lens when attaching to the top).

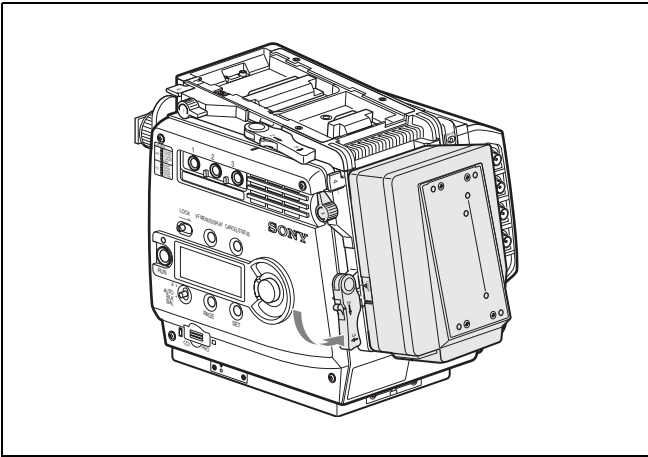

- 6** While holding the lock-release knob in the direction of the arrow, fold the accessory mount lever into its home position.

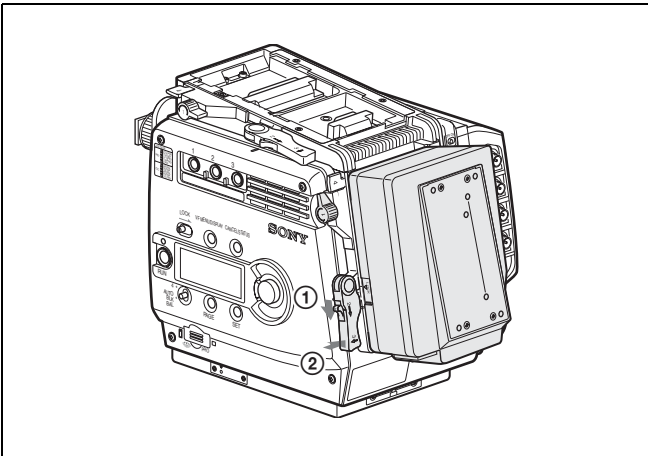

- 7** Rotate the accessory clamp lever downward (toward the opposite direction of the lens when attaching to the top).

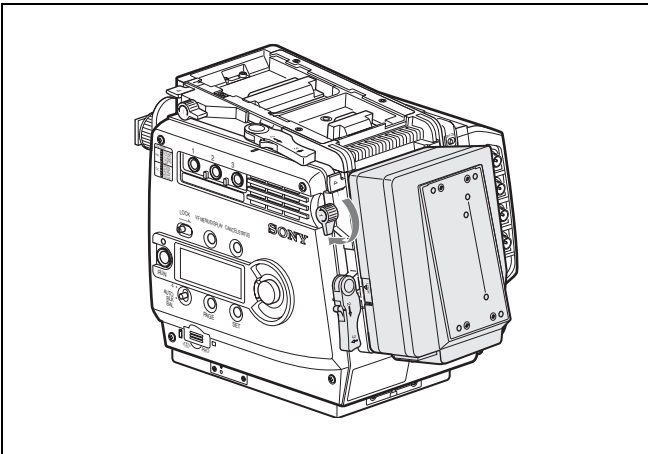

To detach

- 1** Rotate the accessory clamp lever upward (toward the lens when attaching to the top) (① in the figure below).
- 2** Release the lock by sliding the lock-release knob in the direction of the arrow (② in the figure below) then pull up on the accessory mount lever (③ in the figure below) (pull it toward the lens when mounting on the top).

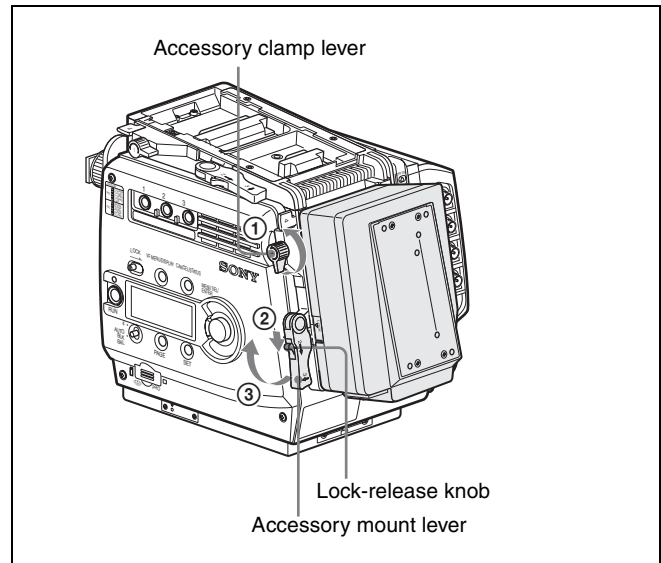

- 3** While holding the safety release tab pressed inward, pull up on the interface box to disengage the connectors, then pull out the box horizontally. (When attaching to the top, hold the safety release tab pressed downward, slide the interface box toward the lens to disengage the connectors, then pull out the box vertically).

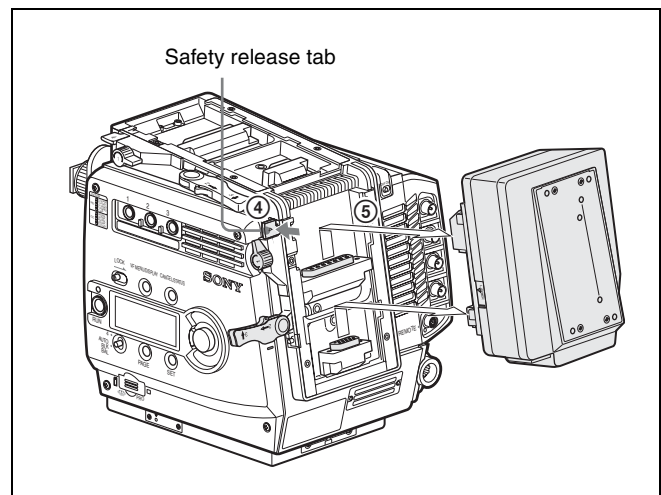

- 4** Return the accessory mount lever and accessory clamp lever to their home positions.

2-2 Mounting the SRW-1 Recorder

In the same manner as the interface box, the SRW-1 HD Portable Digital Recorder can be mounted on the top or rear of the camera head.

For handling of the SRW-1 Recorder, refer to the Operation Manual of the recorder.

Notes

- The firmware of the SRW-1 may be required to be updated for use with the camera.

For details, consult your Sony representative.

- When mounting the recorder, fix the camera head on a tripod in advance to keep the camera head stable.

For tripod mounting, see “2-5 Mounting the Camera to a Tripod” (page 22).

Mounting to the top

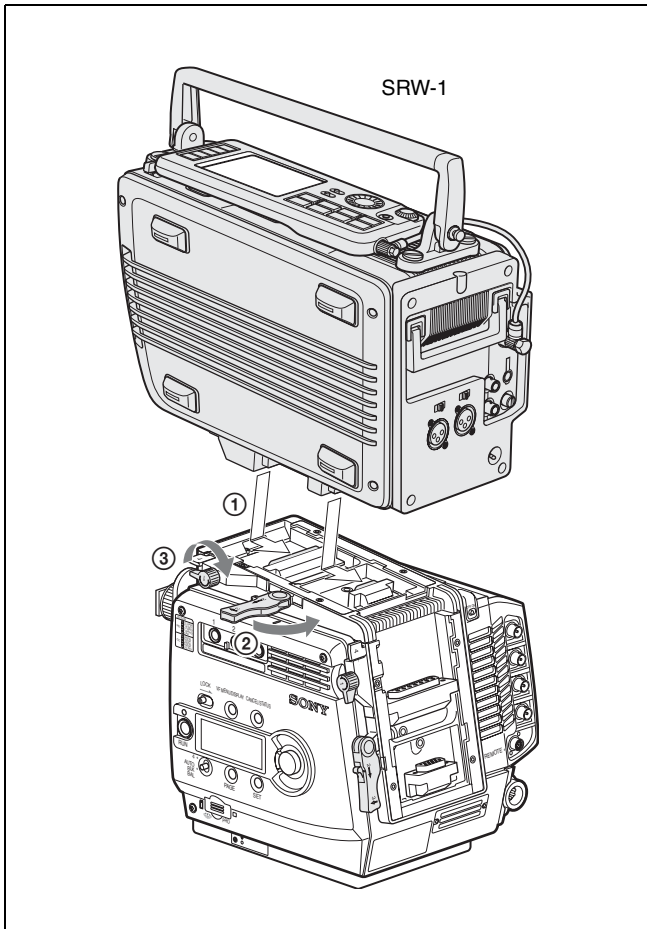

Mounting to the rear

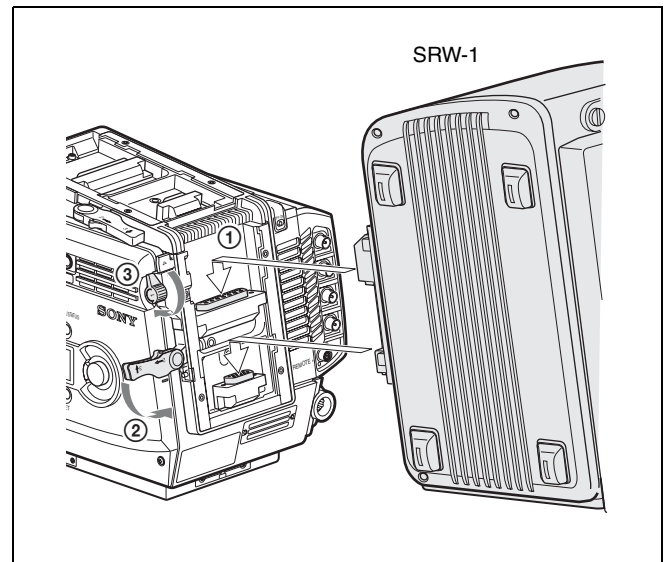

When connecting the SRW-1 recorder using cables

Attach the SRPC-1 HD Video Processor to the recorder to permit cable connections to the interface box mounted on the camera.

Use two coaxial cables for connections. The cable length can be extended up to 100 m when 5C-FB cables are used. The camera and recorder must be controlled independently when connected via cables.

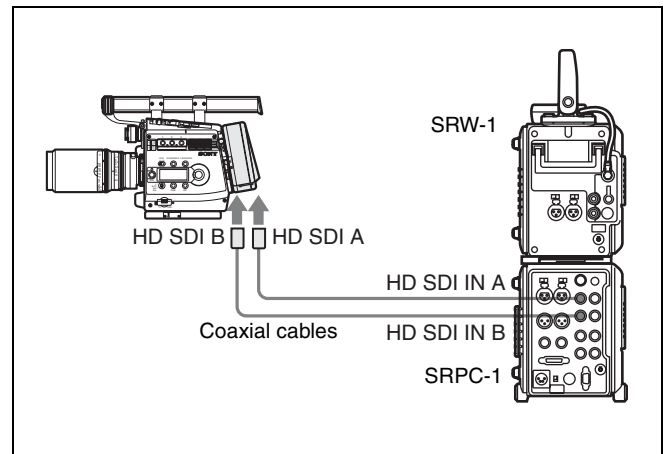

2-3 Attaching a Lens

Use an appropriate optional lens that conforms to the B4 (2/3") lens mount.

For information on handling lenses, refer to the lens' operation manual.

- 1 Pull the lens fixing lever upwards and remove the lens mount cap from the lens mount.

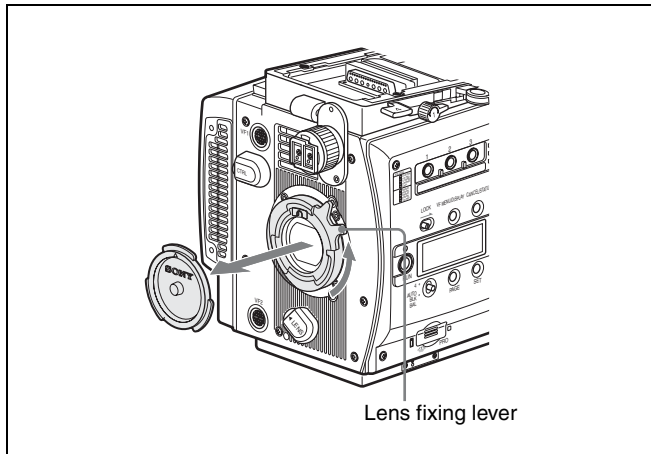

- 2 Align the lens' alignment pin with the notch in the upper part of the lens mount and insert the lens (sold separately) into the mount.
- 3 While supporting the lens, push the lens fixing lever downward to secure the lens.

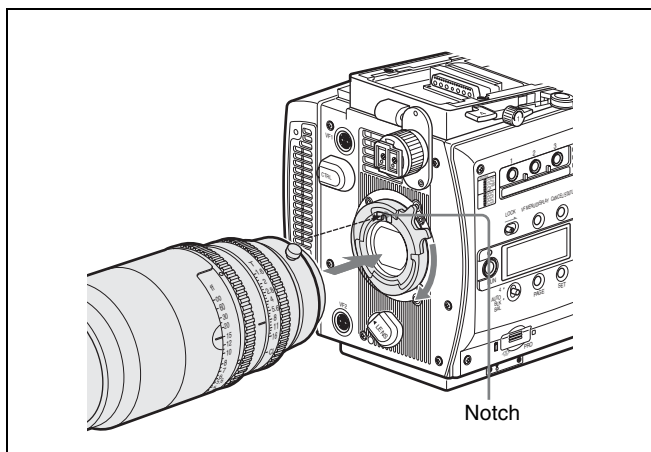

When a lens with a lens cable has been mounted, connect the cable to the LENS connector located at the lower left of the lens mount.

Selecting a lens file

If a lens file for the mounted lens has been registered in the built-in memory, specify the file on the subdisplay.

For lens file selection on the subdisplay, see "3-2-6 Selection of a Lens File" (page 31).

For details on the lens files, see "5-1 File Configuration" (page 78).

Adjusting the flange focal length

Adjustment of the flange focal length¹⁾ is necessary in the following situations:

- The first time a lens is attached
- When changing lenses
- When zooming, and the focus is not sharp at both telephoto and wide angle

Note

The parts of the lens used in adjusting the flange focal length are in different positions on different lenses. Refer to the lens' operation manual.

The procedure for adjusting the flange focal length is as follows:

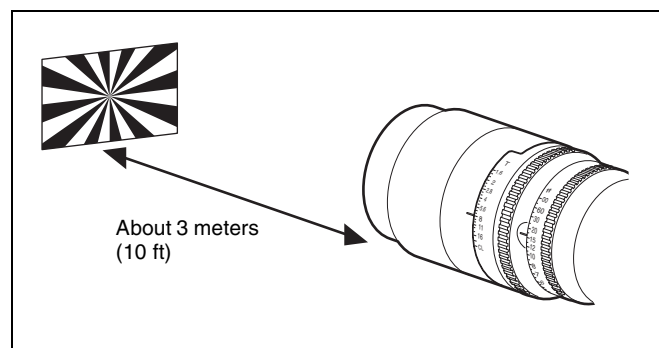

- 1 Set the iris control to manual and open the iris fully.
- 2 Place a flange focal length adjustment chart approximately 3 meters from the camera and adjust the lighting to get an appropriate video output level.
- 3 Loosen the Ff²⁾ ring lock screw.
- 4 With either manual or power zoom, set the zoom ring to telephoto.
- 5 Aim at the flange focal length adjustment chart and turn the focus ring to focus the image.
- 6 Set the zoom ring to wide angle.
- 7 Turn the Ff ring to bring the chart into focus. Take care not to move the distance ring.

8 Repeat steps **4** through **7** until the image is focused at both telephoto and wide angle.

9 Tighten the Ff ring lock screw.

- 1) Flange focal length: The distance between the lens mount attachment plane and the imaging plane
- 2) Ff: Abbreviation of flange focal length

2-4 Attaching a Viewfinder

Note

When the viewfinder is attached, do not leave the camera with the eyepiece facing the sun. Direct sunlight can enter through the eyepiece, be focused in the viewfinder and cause fire.

For details on the viewfinder, refer to the instruction manual of the viewfinder.

- 1** If the viewfinder must be attached higher, loosen the two screws, using the 2.5-mm wrench stored in the wrench box (*page 14*) to detach the viewfinder shoe, and attach it to the upper position using the upper screw holes.

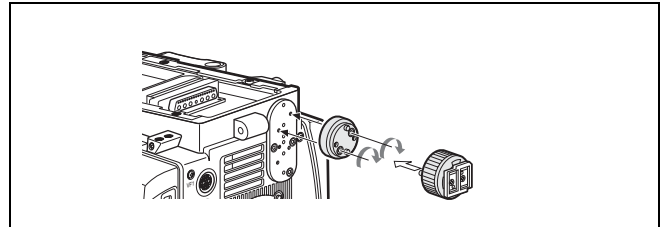

- 2** Fit the viewfinder to the viewfinder shoe and slide the viewfinder horizontally.

The viewfinder stopper automatically pops down.

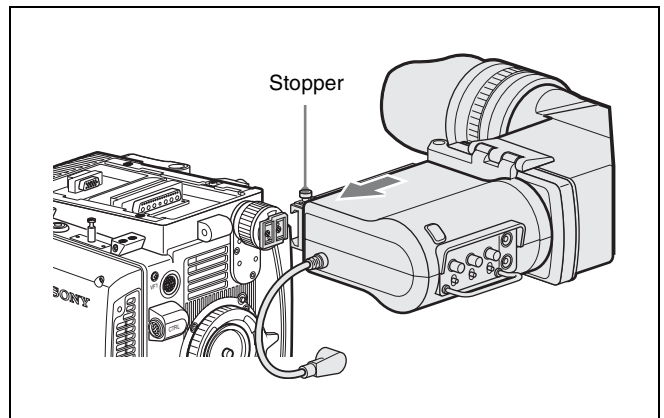

- 3** Set the viewfinder to the most convenient position, tighten the viewfinder positioning ring (① in the figure below), and connect the viewfinder cable to the VF1 connector of the camera (② in the figure below).

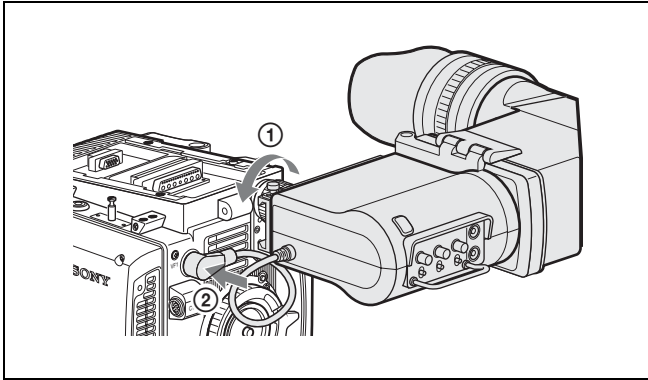

Note

When the L handle is attached to the camera head, the attaching condition may be limited, owing to the viewfinder position and the rotating position of the hood.

When the second viewfinder is required

Connect it to the VF2 connector.

Using the menus, you can specify the display condition independently of the viewfinder connected to the VF1 connector.

To detach the viewfinder

Loosen the viewfinder positioning ring, pull on the viewfinder stopper, then pull out the viewfinder by sliding it in the direction opposite that when attaching.

2-5 Mounting the Camera to a Tripod

Two tripod receptacles (for $\frac{3}{8}$ " camera screws) are provided on the bottom of the camera head.

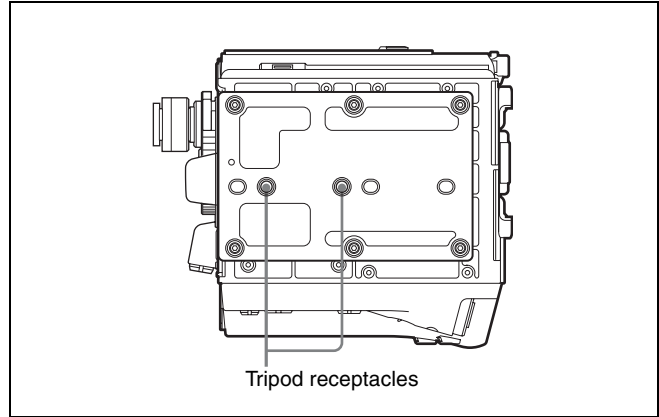

Notes

- Select an appropriate hole, considering the balance of the weight of the camera. If an inappropriate hole is selected, the camera may fall over.
- Check that the size of the selected hole matches that of the screw of the tripod. If they do not match, the camera cannot be attached to the tripod securely.

2-6 Attaching/Detaching Handles

2-6-1 L Handle

The L handle is attached to the top of the camera head at the factory.

Three screw holes (for $\frac{3}{8}$ " camera screws for a tripod) on the upper side of the L handle can be used for fixing various accessories.

Mounting the assistant panel

By attaching the supplied assistant panel hanger, you can mount the assistant panel on the outside of the handle.

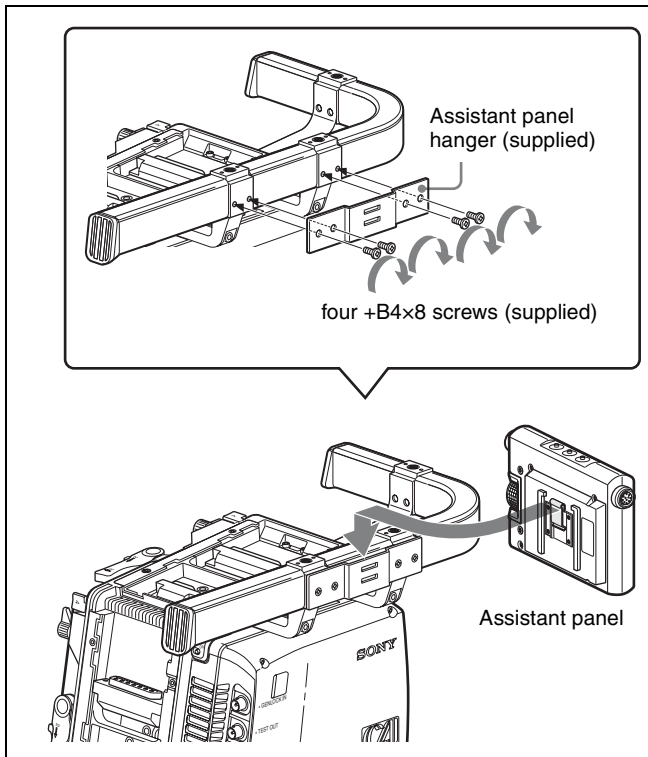

Detaching the L handle

If the L handle is not necessary or to be replaced with the supplied center handle, remove it by loosening the two screws, using the 3-mm wrench stored in the wrench box (page 14).

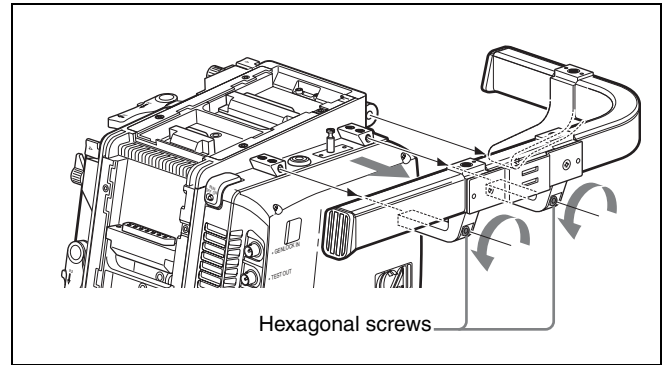

To attach the handle in the original position, reverse the procedure for detaching.

2-6-2 Center Handle (Supplied)

The supplied center handle can be attached to the top or rear of the camera head.

Attach it so that the slanting side faces the back (or bottom).

The screw holes on the upper side of the handle can be used for fixing various accessories.

Attaching the handle directly to the camera head

The handle can be attached/detached in the same manner as the interface box (see page 17).

Attaching the handle to the interface box mounted on the camera head

First remove the base plate from the handle by loosening the four screws, then attach it to the interface box.

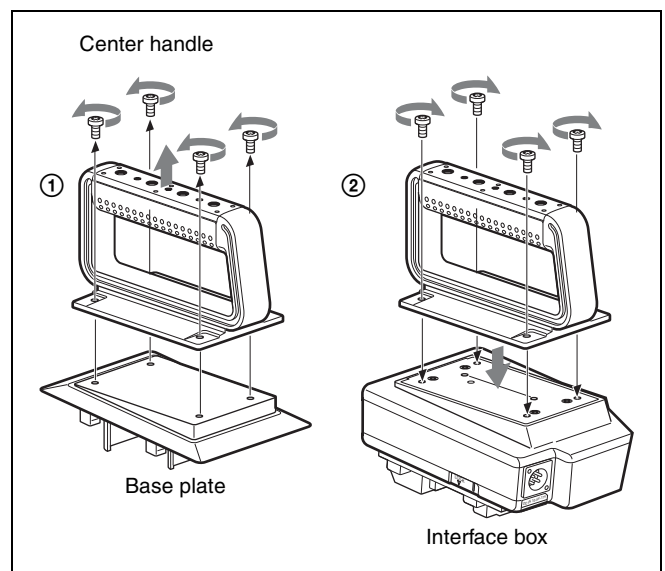

2-7 Preparing the Power Supply

This camera operates on DC 12 V (10.5 to 17 V).

Supplying power directly to the camera head

Connect a power supply to the DC IN connector of the camera head.

Use a commercially available shielded cable by attaching the supplied 8-pin connector for a power cable.

For details on the connection, consult your local Sony representative.

To turn on the camera

Set the CAM POWER switch of the camera head to the ON side, and the camera is turned on.

Power is also supplied to the viewfinder and lens mounted on the camera head.

Power of 12 V or 24 V can be fed to accessories via the DC OUT connectors.

Supplying power via the interface box

To supply power via the interface box, mount the interface box to the rear of the camera head. If the interface box is mounted on the top, the power is not fed to the camera head.

Connect a power supply to the DC IN connector (XLR 4-pin) of the interface box.

To turn on the camera

Set the CAM POWER switch of the camera head to the CA side, and the camera is turned on.

The power is also supplied to the viewfinder and lens mounted on the camera head.

To use an AC power source

An AC power source can be connected, by using the AC-DN2B AC Adaptor.

- 1 Attach the AC-DN2B to the interface box.
- 2 Connect the DC power cord supplied with the AC-DN2B to the DC IN connector of the interface box.
- 3 Connect the AC-DN2B to an AC power source.

To use a battery pack

The BP-GL95 Lithium-ion Battery Pack can be used.

By attaching the BKP-L551 Battery Adaptor to the interface box, connect the BP-GL95 Lithium-ion Battery

Pack to the interface box.

Notes

- Remove the battery pack if the camera will be out of use for an extended period.
- Charge the battery, using the specified battery charger, before use.

For charging, refer to the instructions for the battery charger.

- 1 Attach the BKP-L551 Battery Adaptor to the interface box.

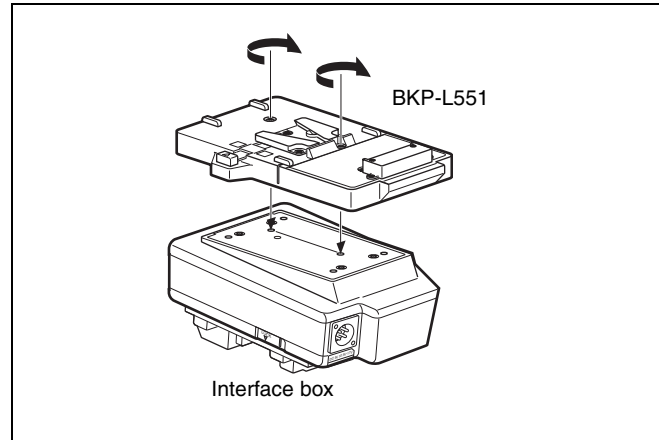

- 2 Aligning the groove on the BP-GL95 with the projection on the BKP-L551, slide the BP-GL95 so that the connectors engage.
- 3 Connect the DC cable of the BKP-L551 to the DC IN connector of the interface box.

When the battery is connected to the DC IN connector of the interface box, power is fed to the camera head, viewfinder, and lens.

Note

Power is not supplied to the recorder mounted on the camera head. To supply power to the recorder, connect a power supply to the DC IN connector on the camera head.

2-8 Setting the Built-in Clock

When using the camera for the first time, set the built-in clock to the local time, using the <DATE> page of the MAINTENANCE menu displayed on the viewfinder screen.

To set the menu on monitor screen, connect a monitor to either of the MONITOR OUT HD SDI connectors.

Setting procedure

- 1 Turn on the camera.
- 2 While holding the MENU SEL/ENTER dial pressed, press the VF MENU/DISPLAY button.

The camera enters Menu Operation mode, and “TOP” is displayed at the upper-right corner of the screen.
- 3 Rotate the MENU SEL/ENTER dial to set the pointer to “TOP” and push on the MENU SEL/ENTER dial.

The TOP MENU screen is displayed.

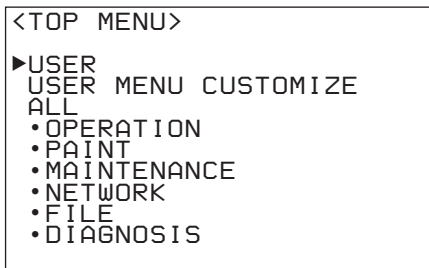

- 4 Rotate the MENU SEL/ENTER dial to position the pointer to MAINTENANCE and push on the MENU SEL/ENTER dial.

The CONTENTS page of the MAINTENANCE menu is displayed.

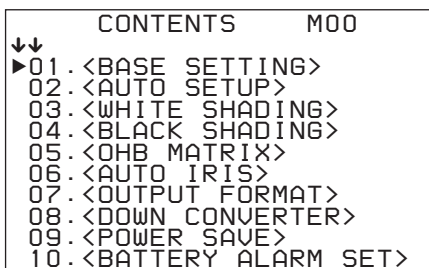

- 5 Turn the MENU SEL/ENTER dial to scroll the page and position the pointer to <DATE>.

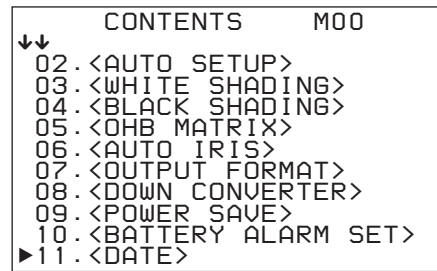

- 6 Push on the MENU SEL/ENTER dial.

The <DATE> page is displayed.

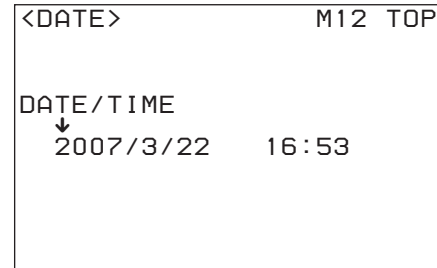

- 7 Turn the MENU SEL/ENTER dial and set the date and time.

Push on the MENU SEL/ENTER dial to shift to the next digit.
- 8 When the date/time setting is completed, press the VF MENU/DISPLAY button to exit Menu Operation mode.

For details on menu operations, see “4-2 Basic Menu Operations” (page 52).

3-1 Selection of the Basic Operation Modes

3-1-1 Overview of the Basic Operation Modes

With this camera, Cine mode and Custom mode can be switched. Cine mode is designed for shooting the materials that will undergo post-production editing and that do not need on-set grading, as with shooting with a film camera. Custom mode is designed for shooting with all the setting items of the camera set as you wish.

The items that can be set and the selectable values on the menus and from the remote control unit are different in Cine mode and Custom mode.

Cine mode (default mode)

- The subdisplay and the USER menu are mainly used.
- Most of the items on the PAINT and MAINTENANCE menus are fixed at the default values.
- Only auto black balance (ABB) can be activated as auto setup.

The white balance level is fixed at the preset value (3200K), and auto white balance (AWB) and WHITE R/G/B settings are not operative.

- On a remote control unit connected to the REMOTE connector of the camera, the values for the adjustment items whose settings fixed in Cine mode are not displayed. However, data for the ON/OFF setting items and selectable items are displayed although they are fixed in Cine mode.
- Reading/writing of files from/to a “Memory Stick” and data presetting are enabled only for the operator file that is included in the USER menu.
- Only retrieval by specifying a file number is allowed among the lens file operations.
- The reference file items are fixed to the default values set at the factory even if you have changed the values in Custom mode.

Custom mode

- This mode is designed for shooting with detailed settings on the menus or with operations from the remote control unit.
- The reference file, which stores the values to be used as reference for adjustments, and the scene files, which store the adjustment values specific to a particular scene, are available in this mode.
- User Gamma can be installed.
- Modification and storage of the lens files are possible.

Note

The settings for the file items adjusted in Custom mode are maintained when the camera is switched back to Cine mode. However, the video adjustment values that are temporarily changed and not stored in any file will be cleared upon mode switching.

For details on different items and values that can be set in each mode, see “4-3 Menu List” (page 55).

3-1-2 Switching of the Basic Operation Modes

At shipment, Cine mode is selected.

To switch to Custom mode

Referring to the procedures described in “2-8 Setting the Built-in Clock” (page 25), call up the <BASE SETTING> page of the MAINTENANCE menu on the viewfinder screen or the monitor screen and switch the modes.

On the same page, making settings for dynamic range and color space is also possible.

<BASE SETTING> page of the MAINTENANCE menu

```

<BASE SETTING>   M01 TOP
SHOOT MODE :▶CUSTOM
D-RANGE     : EXTEND
COLOR SPACE : WIDE
  
```

SHOOT MODE

Switch between CINE and CUSTOM on this line.

D-RANGE

With EXTEND, the dynamic range and sensitivity are improved. The S/N ratio is improved with NORMAL.

COLOR SPACE

To shoot with color space equivalent to that available with conventional cameras, set to F900.

The WIDE setting permits you to shoot with color space wider than that with conventional cameras.

Note

WIDE Color Space mode is appropriate for viewing on a wide color space display, for film conversion, and for color space conversion processes in post production. Images shot with the WIDE setting will be seen in somewhat pale colors if they are reproduced on a conventional narrow color space display. Select WIDE or F900, depending on your purpose.

For details on menu operations, see “4-2 Basic Menu Operations” (page 52).

3-2 Basic Settings with the Subdisplay

Basic settings of the camera can be easily performed, using the subdisplay located on the side of the camera or that of the assistant panel if connected via the CONTROL PANEL connector of the camera.

3-2-1 Basic Operation of the Subdisplay

For operation of the subdisplay, the buttons and dial shown in the figures below are used:

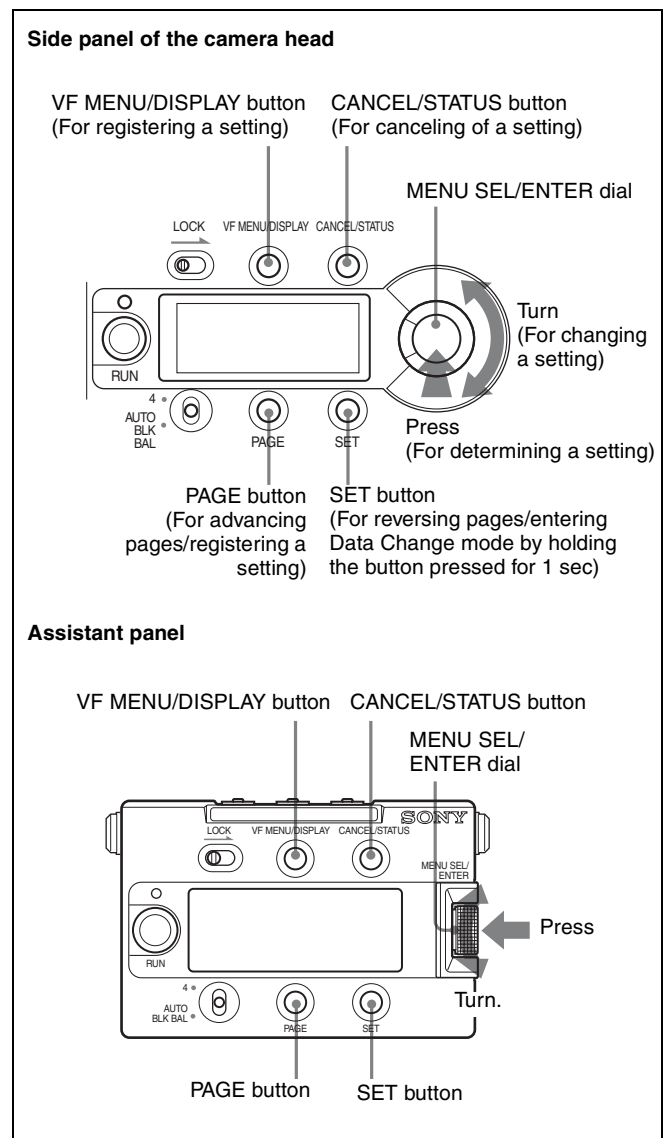

Operations of the subdisplay are possible with the buttons and dial both sides of the camera and assistant panel.

However, the LOCK switches disable the buttons and dial on their own sides. To inhibit operations on either side, set the LOCK switch on the side to be inhibited to ON.

Turning the MENU SEL/ENTER dial can change a setting, and pressing on it can register (ENTER) a setting.

To display the Setting pages

After the camera is turned on, the selected operation mode (CINE or CUSTOM) is displayed on the subdisplay for several seconds, after which the Setting page that was operated last time is displayed.

To advance to the next page

Press the PAGE button.

To go back to the previous page

Press the SET button (press and release the button within 1 second).

To change a setting

Press and hold the SET button for more than 1 second. Data Change mode is entered, the cursor (|) starts flashing, and the question mark (?) symbol appears at the rightmost position on the first line.

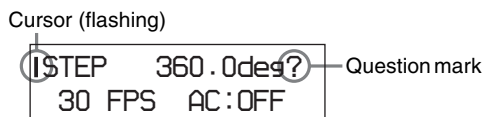

On a page with two or more setting items, each time the SET button is pressed, the cursor moves to the next item.

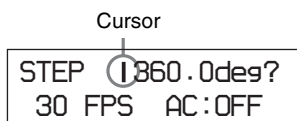

Move the cursor to the item you wish to modify then change the setting by turning the MENU SEL/ENTER dial.

Note

While the subdisplay is in Data Change mode, menu operations on the viewfinder cannot be performed.

To determine a changed setting

Perform one of the following:

- Press the PAGE button.
- Exit Data Change mode by pressing the MENU SEL/ENTER dial (the cursor and question mark disappear).
- Terminate the subdisplay operation by pressing the VF MENU/DISPLAY button.

To cancel a change on a setting

Without registering a change of a setting, press the CANCEL/STATUS button. The question mark disappears, and the original setting is restored.

To terminate subdisplay operation

Press the VF MENU/DISPLAY button.

3-2-2 Shutter Settings

With the electronic shutter ON, the shutter angle or shutter frequency (speed) can be selected.

The selected shutter values can be checked with the status indications displayed on the upper side of the viewfinder (page 39).

When the frequency indication is assigned, the value converted depending on the selected frame rate (number of frames per second) will be displayed. The value with the frequency value as a denominator will be the shutter speed.

Step Shutter mode

The eight most frequently used shutter values can be registered as step shutters and can be selected by specifying the number.

At shipment, the following values are registered:

No.	Shutter angle
STEP1	360.0°
STEP2	216.0°
STEP3	180.2°
STEP4	172.5°
STEP5	150.1°
STEP6	145.0°
STEP7	107.8°
STEP8	89.9°

The corresponding shutter frequencies vary according to the frame frequency and frame rate of the selected video format. The step shutter values can be changed and re-registered on the <SHUTTER ASSIGN> page of the USER (OPERATION) menu.

Variable Shutter mode (ECS)

Shutter values that have not been registered as step shutters can be used in Variable Shutter mode.

Note

In a case where the remote control unit that is connected to the REMOTE connector of the camera is used, Variable Shutter mode is entered with ECS ON, and Step Shutter mode is entered with SHUTTER ON. However, to display the shutter frequencies and angles correctly, upgrading of the version is required.

For details, consult your local Sony representative.

Shutter setting page

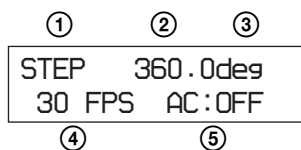

To select the step shutter

In Step Shutter mode, one of the registered eight shutter values can be selected, as follows:

- 1 Select STEP at ①.
- 2 Move the cursor to ② by pressing the SET button.
- 3 Display the shutter angle you wish to use by turning the MENU SEL/ENTER dial.

The registered eight values for shutter angle will be displayed one after another as the MENU SEL/ENTER dial is turned.

To select an arbitrary shutter value

To use a shutter value that is not registered as a step shutter, use Variable Shutter mode.

- 1 Select VAR at ①.
- 2 Move the cursor to ② by pressing the SET button.
- 3 Display the shutter value you wish to use by turning the MENU SEL/ENTER dial.

The shutter value changes continuously as the MENU SEL/ENTER dial is turned.

The displayed units for the shutter values can be switched between deg (shutter angle) and Hz (frequency) at ③.

The shutter frequency converted from the shutter angle varies according to the selected video format and frame rate.

To select the frame rate (number of frames per second)

When a video format prefixed with S is selected, the frame rate (number of frames per second) can be selected.

- 1 Move the cursor to ④.
- 2 Display the frame rate (number of frames per second) you wish to use by turning the MENU SEL/ENTER dial.

If a format that is not prefixed with S is selected, the frame rate cannot be changed.

To turn Angle Compensation mode ON/OFF

When the Angle Compensation mode is OFF, if the frame rate is changed, the shutter frequency will be corrected while the current shutter angle is retained. When Angle Compensation mode is ON, if the frame rate is changed, the shutter angle will be corrected while the current shutter frequency is retained.

- 1 Move the cursor to ⑤.
- 2 Select ON or OFF by turning the MENU SEL/ENTER dial.

Two shutter compensation modes are provided for this camera: Angle Compensation mode and Gain Compensation mode. On the subdisplay, only Angle Compensation mode can be switched ON or OFF. When Angle Compensation mode is ON, Gain Compensation mode (ON/OFF switched with the menu) is forcibly turned OFF.

For details on switching of the compensation modes with the menu, see “3-9 Detailed Shutter Settings” (page 45).

When shutter is not used

Select OFF at ①.

To change the registered values for the step shutter

Call up the <SHUTTER ASSIGN> page of the USER (OPERATION) menu on the viewfinder.

For details on how to operate the menu, see “4-2 Basic Menu Operations” (page 52).

<SHUTTER ASSIGN> page

<SHUTTER ASSIGN>		12	TOP
STEP	[deg]	[Hz]	
*1:	▶360.0	(23.98)	
2:	216.0	(39.96)	
3:	180.2	(47.91)	
4:	172.5	(50.04)	
5:	150.1	(57.51)	
6:	145.0	(59.54)	
7:	107.8	(80.04)	
8:	89.9	(95.99)	

In the [deg] column on each line, assign an appropriate angle. Values in the range of 360.0 to 4.2 can be assigned. In the [Hz] column, the converted frequency value depending on the currently selected frame rate is displayed.

3-2-3 Selection of Video Formats

On the subdisplay, the video format can be selected from among the three registered formats.

At shipment, the following three formats are registered:

No.	Registered format	Indication on the subdisplay
1 (default)	23.98PsF 4:4:4	_23P 444
2	S23.98PsF 4:4:4	S23P 444
3	S59.94P 4:2:2	S59P 422

Video-format selection page

```

      _23P 444
1 : _23P 444
  
```

On the first line, the currently selected format is displayed. On the second line, you can select the desired format from among the registered formats 1 to 3.

Turn the MENU SEL/ENTER dial until the desired format is displayed on the second line.

To change the registered formats that can be selected on the subdisplay

The registered formats 1 to 3, which can be selected on the subdisplay, can be changed on the <ASSISTANT PNL> page of the USER (OPERATION) menu.

For details on how to operate the menu, see “4-2 Basic Menu Operations” (page 52).

<ASSISTANT PNL> page

```

<ASSISTANT PNL> 13
FORMAT 1 : ▶_23P 444
        2 : S23P 444
        3 : S59P 422
  
```

Position the pointer on the line you wish to change and push on the MENU SEL/ENTER dial. The <FORMAT SEL> subpage for format selection will be displayed.

<FORMAT SEL> page

```

<FORMAT SEL>          ESC
↓
▶00 : NO ASSIGN
01 : _23P 444
02 : S23P 444
03 : _24P 444
04 : S24P 444
05 : _25P 444
06 : S25P 444
07 : _29P 444
08 : S29P 444
09 : S30P 444
  
```

Position the pointer to the format you wish to select and push on the MENU SEL/ENTER dial. The registered format will be changed.

If NO ASSIGN is selected, selection with that number becomes invalid.

To set the video formats in the same interface with the SRW-1 recorder

Set the video formats, using the <OUTPUT FORMAT> page of the MAINTENANCE menu.

For details on how to select the video formats, see “3-14 Detailed Setting of the Video Format” (page 49).

3-2-4 Selection of the Filters

To respond to various lighting or natural light conditions, optical neutral density (ND) filters and optical color temperature conversion (CC) filters are built into this camera. The selectable filters are identified with the following alphanumeric:

Indication	Selected filter	Indication	Selected filter
ND: 1	CLEAR	CC: A	3200K (Clear)
ND: 2	ND0.6 (1/4 ND)	CC: B	4300K
ND: 3	ND1.2 (1/16 ND)	CC: C	5600K
ND: 4	ND1.8 (1/64 ND)	CC: D	6300K
ND: 5	CAP	CC: E	ND0.3 (1/2 ND)

At shipment, ND:1 to ND:5 are allocated to assignable button 1, and the CC:A to CC:E are allocated to assignable button 2 for selection.

On the subdisplay, the selected built-in optical filter can be confirmed and switched to another filter, as required.

Optical filter selection page

```

①          ②
ND: 1      CLEAR
CC: B      3200K
③          ④
  
```

Select one of the ND:1 to ND:5 filters at ①.
The type of the filter selected at ① is displayed at ②.
If CC:E is selected at ③, the sum of the ND values of the filters selected at ① and ③ is displayed at ②.

Select one of the CC:A to CC:E filters at ③.
The color temperature corresponding to the filter selected at ③ is displayed at ④.

If CC:E is selected, the correction value of the ND filter that is selected on the ND side is halved.
Example: In a case where ND:3 and CC:E are selected, the ND value is equivalent to 1/32ND.

The electrical gain 5600K selection has no effect on the display at ④.

3-2-5 Selection of the Gain, Color Temperature, and White Balance Memory

The setting items and values in Cine mode and Custom mode are different.

In Cine mode: Select the gain and color temperature

Gain/color temperature selection page

0dB TUNGSTEN

On the first line, the gain value is selected from among the following: -3 dB, 0 dB, 3 dB, 6 dB, 9 dB, and 12 dB.

On the second line, the color temperature is selected from TUNGSTEN or DAYLIGHT.

With DAYLIGHT, the electrical gain 5600K is ON.

At shipment, the gain is set to 0 dB, and the color temperature is set to TUNGSTEN.

The white balance adjustment value is fixed at the preset value (3200K).

In Custom mode: Select the gain, color temperature, and white balance memory

Gain/color temperature/white balance memory selection page

0dB	
5600K-ON	W:P
①	②

On the first line, the gain value is selected from among the following: -3 dB, 0 dB, 3 dB, 6 dB, 9 dB, and 12 dB.

At ① on the second line, the electrical gain D5600K can be switched ON or OFF.

At ② on the second line, the white balance adjustment value can be selected.

Setting	Adjustment value
W:P	Preset value (3200K)
W:A	The value stored in memory A
W:B	The value stored in memory B
W:C	The value stored in the memory cell that is called up when memory A and memory B are turned off from a remote control unit

At shipment, the gain is set to 0 dB, color temperature is set to 5600K-OFF, and the white balance memory is set to W:P.

For details on white balance adjustment, see “3-4 White Balance Adjustment (in Custom mode)” (page 34).

3-2-6 Selection of a Lens File

This camera permits you to register the compensation data for the mounted lens as a lens file in built-in memory (max. 32 files).

If a lens file for the mounted lens has already been registered, select it on the subdisplay. The compensation data that were adjusted for that lens will be invoked.

Lens file selection page

LENS: 1 No Offset

On the first line, select the number of the lens file.

On the second line, the lens-file name corresponding to the selected file is displayed.

The selected lens file will be retained until a new lens file is selected. As long as the same lens is used, further selection of the lens file is not required.

Note

All the lens files are named “No Offset,” with all zero settings at shipment. File registration and modification of data in a lens file must be performed in Custom mode.

For details on the lens files, see “Chapter 5 Storage and Retrieval of User Setting Data”.

3-2-7 Confirmation of the Time Code and Tape Remaining

When the SRW-1 HD Portable Digital Recorder is attached to this camera, the time code of the recorder and approximate tape remaining (unit: minutes) can be confirmed on the subdisplay.

Time code/tape remaining display page

```
TCR 00:00:00:00
20min
```

The time code is displayed on the first line, and the approximate tape remaining is displayed on the second line, in the range of 1 to 99 min.

Time code that is displayed on the first line

Indication	Meaning
TCR 00:00:00:00	Time code data of the LTC reader
TCR 00:00:00:00	Time code data of the LTC reader (DF)
TCR.00:00:00:00	Time code data of the VITC reader
UBR 00 00 00 00	User bit data of the LTC reader
UBR.00 00 00 00	User bit data of the VITC reader
TCG 00:00:00:00	Time code data of the time code generator
TCG 00:00:00:00	Time code data of the time code generator (DF)
UBG 00 00 00 00	User bit data of the time code generator
CTL -0:00:00:00	Data of the CTL counter
T*R 00:00:00:00	Time code cannot be read with the LTC reader
U*R 00 00 00 00	User bit cannot be read with the LTC reader
T*R.00:00:00:00	Time code cannot be read with the VITC reader
U*R.00 00 00 00	User bit cannot be read with the VITC reader

The type of the displayed time code data is linked with the SRW-1. Select the type of the displayed time code data on the SRW-1.

3-2-8 Confirmation of the Power Voltage and Selection of Fan Operation Mode

The values in voltage of the power sources connected to the camera can be confirmed on the subdisplay.

On the same page, the operation mode of the built-in fans can also be selected.

Voltage confirmation/Fan Operation mode select page

```
①      ②
11.4V  24.1V
FAN:AUTO1
```

At ① and ② on the first line, the values in voltage of the 12-V and 24-V power systems are displayed, respectively. If power is not supplied, “- -” is displayed.

If the voltage falls to the NEAR END level, the indication starts flashing. If the voltage falls further down to the END level, the indication flashes rapidly.

The NEAR END and END levels can be set on the <BATT ALARM SET> page of the MAINTENANCE menu.

On the second line, Fan Operation mode can be changed.

Setting	Operation of the fans
AUTO1 (default)	The fans rotate at the standard speed.
AUTO2	The fans rotate at the minimum speed equivalent to the MIN speed in REC mode. In other conditions, the fans rotate at the speed equivalent to the AUTO1 speed.
MIN	The fans rotate at the minimum speed.
MAX	The fans rotate at the maximum speed.

3-2-9 ON/OFF of the Character Indication

Superimposition of character data onto camera images can be activated or deactivated by output destination.

Character indication setting page

```
VF1:ON
MON:ON  VBS:ON
```

VF1

Viewfinder connected via the VF1 connector (default: ON)

MON

Monitors connected via the MONITOR OUT HD SDI connectors (default: ON)

VBS

Monitors connected via the TEST OUT and REMOTE connectors (default: ON)

3-2-10 Allocation of Functions to the Assignable Buttons and Switch

Various functions can be allocated to assignable buttons 1 to 3 and assignable switch 4 (the upper position of the 4/AUTO BLK BAL switch) that are located on the side of the camera and on the assistant panel.

At shipment, the ND-filter select function is allocated to button 1, and the CC-filter select function is allocated to button 2. No function is allocated to button 3 and switch 4.

Functions that can be allocated to assignable buttons 1 to 3

Menu indication	Function
ND	Selection of the ND filter
CC	Selection of the CC filter
REC REVIEW	With REC REVIEW set to NORM on the SRW-1, the last part of the recorded tape is normally rewound for 3 seconds (maximum: 10 seconds) then played back. With REC REVIEW set to ALL on the SRW-1, the tape is rewound to the recording start position then played back.
PB(VF)	The video signals being played back on the SRW-1 are output to the viewfinder.
VF709GAM	ON/OFF of the fixed ITU-R709 gamma of the viewfinder
MONI709GAM	ON/OFF of the fixed ITU-R709 gamma of the monitor
FAN MODE	Switching of Fan Operation mode
OFF	None

Functions that can be allocated to assignable switch 4

Menu indication	Function
AWB	Automatic white balance adjustment
BARS	Color-bar indication
TEST1	Test signal output
OFF	None

Note

Even if AWB is allocated to assignable switch 4, AWB does not function in Cine mode.

Assignable buttons 1/2 setting page

```
AS1 : ND
AS2 : CC
```

The functions of buttons 1 and 2 can be assigned on the first and second line, respectively.

Assignable button 3/switch 4 setting page

```
AS3 : REC REVIEW
AS4 : OFF
```

The functions of button 3 and switch 4 can be assigned on the first and second line, respectively.

3-2-11 Brightness Adjustment of the Subdisplay

The brightness of the subdisplay can be adjusted, in eight levels.

Subdisplay brightness adjustment page

```
BRIGHT : 1
```

The higher the value, the brighter the display.

3-3 Black Balance Adjustment

In order to maintain high picture quality when using the camera, it is necessary to set the black balance appropriately. After turning on the camera, apply power to the camera for several minutes, then be sure to perform the black balance adjustment before starting any picture adjustment.

Automatic black balance adjustment

Push the assignable switch 4/AUTO BLK BAL switch on the side of the camera or on the assistant panel down to the position AUTO BLK BAL then release it. Automatic black balance adjustment is performed.

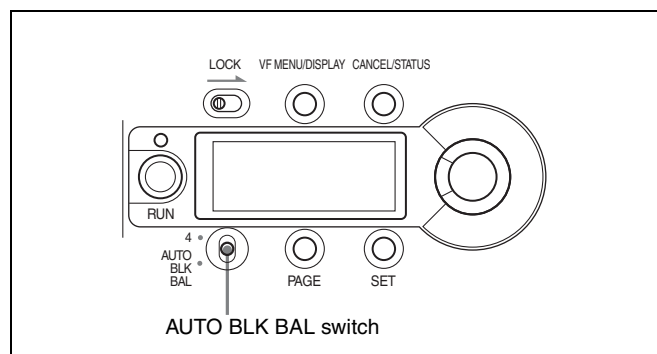

During adjustment, “ABB: EXECUTING” is displayed on the viewfinder screen. When the adjustment process is completed successfully, the message “ABB: OK” is displayed.

Notes

- During black balance adjustment, ND is automatically set to 5 (CAP), and the iris is closed.
- During black balance adjustment, the gain switching circuit will work automatically, and the viewfinder screen will flicker several times. This is not a malfunction.

When automatic black balance adjustment fails

If the automatic black balance adjustment process does not end successfully, the error message “ABB: NG” will be displayed on the viewfinder screen for approximately three seconds.

If this error message is displayed, try black balance adjustment again.

If the error message continues to be displayed after several attempts, the camera requires internal inspection.

3-4 White Balance Adjustment (in Custom mode)

When the camera is used in Custom mode, if the lighting conditions change, readjust the white balance.

When adjusting the white balance, select the white balance memory. The adjustment value is fixed to 3200K when the preset memory is selected.

The selected memory can be confirmed with the status display on the viewfinder screen (page 39).

The memory selection can be made on the subdisplay or from a connected RM-B150/B750 Remote Control Unit.

Automatic white balance adjustment

- 1 Select the memory A, B, or C, using the subdisplay or the remote control unit (default: preset memory).

Memory C can be selected only when the Remote Control Unit is used,

For details on how to select on the subdisplay, see “3-2-5 Selection of the Gain, Color Temperature, and White Balance Memory” (page 31).

- 2 Select the appropriate filter according to the lighting conditions, using the subdisplay or the assignable buttons.

See “3-2-4 Selection of the Filters” (page 30).

- 3 Place a white pattern in the same lighting conditions as the subject and zoom in on it so that a white area is obtained in the screen.

A white object (white cloth, a white wall, etc.) near the subject may be used in place of a white pattern.

The minimum white area required for adjustment is as illustrated below:

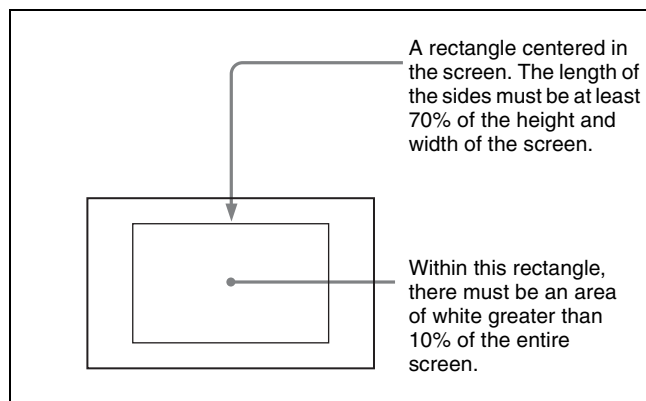

Note

Be careful not to have any spots of high illumination in the rectangle.

4 Adjust the lens iris opening or set the shutter to ON.

With a manually adjusted lens: Set the opening to an appropriate value.

With a lens that has automatic iris control: Set the lens' automatic/manual iris control switch to automatic.

Or, set the video level to an appropriate value, using the shutter setting.

5 Perform automatic white balance adjustment.

To perform adjustment on the <AUTO SETUP> page of the MAINTENANCE menu

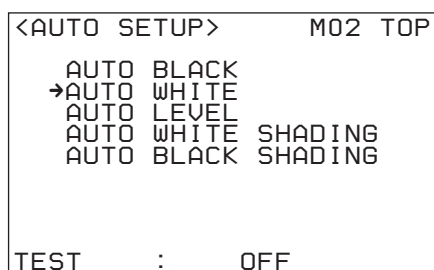

Position the pointer to AUTO WHITE then push on the MENU SEL/ENTER dial.

For details on the menu operations, see “4-2 Basic Menu Operations” (page 52).

To perform adjustment with the assignable switch

If AWB is allocated to assignable switch 4, push the switch up toward “4” then release it.

For the procedure for assigning a function to the switch, see “3-2-10 Allocation of Functions to the Assignable Buttons and Switch” (page 33) or “3-7 Detailed Settings of the Switch Functions” (page 44).

To perform adjustment from the remote control unit

When the RM-B750 or RM-B150 remote control unit that is connected to the REMOTE connector is used, press the AWB button.

During adjustment

The message “AWB EXECUTING” is displayed on the viewfinder screen. When the adjustment process is completed successfully, the message “AWB: OK” is displayed.

When automatic white balance adjustment fails

If the automatic white balance adjustment process does not end successfully, the error message “AWB: NG” will be displayed on the viewfinder screen for approximately three seconds.

If this error message is displayed, try white balance adjustment again.

If the subject has a higher color temperature, use an optical filter or set 5600K to ON, then try white balance adjustment again.

If the error message continues to be displayed after several attempts, the camera requires internal inspection.

3-5 Setting the Camera Outputs

3-5-1 Selecting a Video Output Signal for Each Connector

The type of video signals to be output to the MONITOR OUT HD SDI 1/2, TEST OUT, and REMOTE connectors can be selected.

For selection, use the <MONITOR OUTPUT> page of the USER (OPERATION) menu that is displayed on the viewfinder screen.

<MONITOR OUTPUT> page

```
<MONITOR OUTPUT> 08
COLOR          : ►COLOR
OUTPUT
MONI HD-SDI   : MONI
TEST OUT      : VBS
RM VIDEO      : VBS
```

COLOR

With COLOR, all R, G, and B channels will be output. Single-channel output of R, G, or B is also possible.

MONI HD-SDI

The signals to be monitored with video monitors connected to the MONITOR OUT HD SDI 1/2 connectors can be selected.

Setting	Signal
MONI	Regardless of the VF1/VF2 settings, characters or the marker can be added independently to the video output signals. (Default)
VF1	Video signals that are output to the VF1 connector (camera images with character data for the setting menus and status display)
VF2	Video signals that are output to the VF2 connector

TEST OUT

The signals to be output to a video monitor or waveform monitor connected via the TEST OUT connector can be selected.

Setting	Signal
VBS	The VBS signals are output. (Default)
VF2	The HD-Y signals are output.
REF-THRU	The reference signal that is input to the GENLOCK IN connector is output as-is.
FRAME	A pulse is output per frame (in a case of 1 FPS, one pulse per second).

Timing of the pulse signal

Example 1: SHUTTER OFF

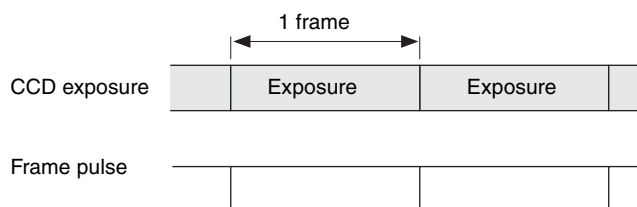

Example 2: SHUTTER ON, shutter angle 180°

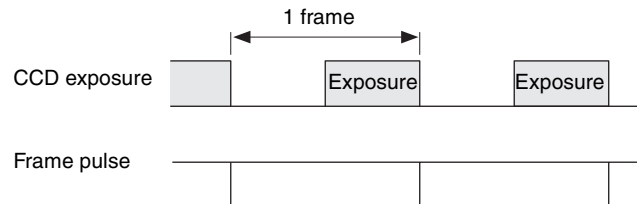

RM VIDEO

The video signals to be output to equipment connected via the REMOTE connector can be selected.

Setting	Signal
VBS	The VBS signals are output. (Default)
VF2	The HD-Y signals are output.

3-5-2 Setting the Monitor Picture

Using the <PB/MONI GAMMA> page of the USER (OPERATION) menu displayed on the viewfinder screen, the gamma setting of the monitor picture and the playback-picture monitor mode can be selected.

<PB/MONI GAMMA> page

```
<PB/MONI GAMMA> 09
MONI GAMMA ENABLE : OFF
                VF  MONI  VBS
PB   : ► OFF  OFF  OFF
PB MIX : OFF  OFF  OFF

MONITOR GAMMA
VF   : OFF
MONI : OFF
VBS  : R709
```

To apply fixed gamma to the monitor picture

MONI GAMMA ENABLE

If this is set to ON, fixed gamma (ITU-R709) appropriate for monitoring¹⁾ is applied to the video signals output from the VF1, VF2, MONITOR OUT HD SDI 1/2, or REMOTE connector. The video output signals from those connectors are selected on the <MONITOR OUTPUT> page.

This setting is effective when S-LOG gamma is applied to the video output signals for recording intended for post-production editing.²⁾

To monitor the playback picture

The playback picture of the recorder can be confirmed with a monitor connected to the camera or on the viewfinder screen.³⁾

PB

The playback-signal output mode can be selected for each VF, MONI, or VBS signal.

Setting	Signal
ON	The playback picture of the recorder is always output.
AUTO	Normally, the camera image is output. When the recorder enters playback mode (PLAY, FF, REW, or REC REVIEW,) the playback picture is automatically selected.
OFF	The camera image is always output. (Default)

Note

If the recorder is turned off with PB ON, the picture on the viewfinder/monitor screen is distorted. The normal picture is restored by turning the recorder on or setting PB to AUTO or OFF.

To compare the playback picture and camera image

The playback picture and camera image can be displayed on the same screen when the playback-signal output mode is set to ON or AUTO for the item PB on the <PB/MONI GAMMA> page and if PB MIX is set to ON.

PB MIX

The playback-signal mix mode can be independently set to ON or OFF for each VF, MONI, or VBS signal. When set to ON, the playback picture and camera image are mixed.

How this is to be displayed can be set on the <PB MIX SETTING> page of the USER (OPERATION) menu.

<PB MIX SETTING> page

<PB MIX SETTING> U10	
MIX TYPE	: ►MIX
MIX DIRECTION	: PB
MIX MODE	: Y-MIX
MIX LEVEL	: 80%
WIPE LAYOUT	: HOR
PB POSITION	: RIGHT
BOUNDARY	: 960

MIX TYPE

How the picture is to be displayed can be selected.

Setting	How to display
MIX	The playback picture and camera image are overlapped. (Default)
WIPE	The screen is horizontally or vertically split in two, and two pictures are displayed simultaneously.

MIX

When MIX TYPE is set to MIX, how to mix the pictures can be selected.

Item	Setting	Content
DIRECTION	CAM	The playback picture is gradually mixed into the camera image. (Default)
	PB	The camera image is gradually mixed into the playback picture.
MODE	Y-MIX	The Y signals are mixed. (Default)
	WIRE(W)	Only the outline components are mixed and displayed with white lines.
	WIRE(B)	Only the outline components are mixed and displayed with black lines.
LEVEL	0 to 80%	The mix level can be adjusted. (Default: 80%)

WIPE

When MIX TYPE is set to WIPE, how pictures are to be wiped can be selected.

Item	Setting	Content
LAYOUT	HOR	Horizontally split (Default)
	VERT	Vertically split

Item	Setting	Content
PB POSITION	RIGHT	With HOR, the playback picture is displayed on the right and the camera image on the left. (Default when HOR is selected)
	LEFT	With HOR, the playback picture is displayed on the left and the camera image on the right.
	BOTTOM	With VERT, the playback picture is displayed in the lower part and the camera image in the upper part. (Default when VERT is selected)
	TOP	With VERT, the playback picture is displayed in the upper part and the camera image in the lower part.
BOUNDARY	With HOR: 0-1920 With VERT: 0-1080	The boundary position can be changed. (Default: with HOR: 960, with VERT: 540)

- 1) The VBS output signal always becomes the camera image to which ITU-R709 gamma is applied.
- 2) With fixed gamma, the Detail settings for the main line are not applied. The fixed pedestal and knee levels are applied. When power saving is not activated for VBS, S23.98PsF/23.98PsF is pulled down to 59.94i and S24PsF/24PsF is pulled down to 50i then output, so that the camera image can be displayed on the viewfinder or a monitor that does not support 23.98PsF/24PsF.
- 3) When MONI GAMMA ENABLE is set to OFF, the same gamma as that applied to the main line is applied to all the outputs. However, the PB and PB MIX modes can be independently selected for the VF, MONI, and VBS signals.

3-5-3 Outputting Color Bars

The color-bar signal can be output by setting the color-bar generator built in the camera to ON.

The color-bar generator can be turned ON or OFF on the <OTHERS 1> page of the USER (MAINTENANCE) menu.

<OTHERS 1> page

<OTHERS 1>	U21
FAN MODE	: AUTO1
CAM BARS	: ►ON
IMAGE INVERT	: OFF

When CAM BARS is set to ON, the color-bar generator is turned ON, and the color-bar signal is output.

Note

The color-bar signal is not output with the video output from the VF1, VF2, MONITOR OUT HD SDI 1/2, and

REMOTE connectors if fixed gamma (R709) is selected for MONITOR GAMMA of the respective output on the <PB/MONI GAMMA> page (except when a VBS signal is output).

3-6 Viewing and Setting the Viewfinder Displays

Besides the video image, the viewfinder can display text and messages showing the camera settings and operation status.

The same information can be displayed on monitors connected to the MONITOR OUT HD SDI connectors.

Note

This information is not displayed when the camera is in Menu Operation mode. Exit Menu Operation mode to view the information.

3-6-1 Viewing the Basic Status Indications

The following status indications can be superimposed on the camera picture when you press the VF MENU/ DISPLAY button.

The display conditions can be specified on the <VF DISPLAY> page of the USER (OPERATION) menu.

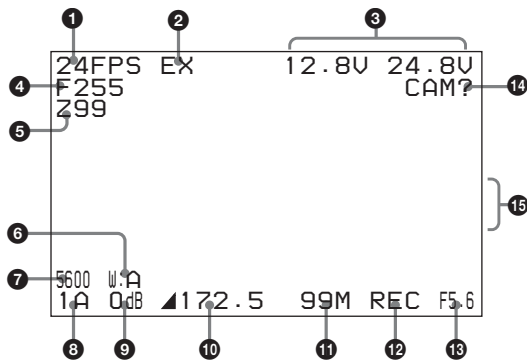

1 Frame rate

The frame rate selected is displayed.
(This indication is not available if the Select FPS function is not active.)

2 Lens extender

“EX” is displayed when a lens extender is in use.

3 Battery indications

The conditions of output power are indicated. The left column is for DC 12V OUT power and the right column is for DC 24 V OUT power.

Each indication begins to flash if the corresponding input voltage decreases to the NEAR END value specified on the

<BATT ALARM SET> page of the MAINTENANCE menu.

Flashing becomes quicker as the voltage decreases further toward the END value.

The set NEAR END and END values can be checked on the <BATTERY ALARM> page of the USER (OPERATION) menu.

4 Focus position

Shows the focus position of a zoom lens as a numeric value in the range of 0 to 255 (infinity).

5 Zoom position

Indicates the approximate position of the zoom lens variator between wide angle (0) and telephoto (99).

6 White balance memory

Displays the currently selected white balance memory.

W:A: Memory A

W:B: Memory B

W:P: Preset memory

The setting is fixed at W:P in Cine mode.

In Custom mode, you can change the setting using the subdisplay or from a remote control unit.

7 Color temperature filter mode

Indicates the condition of the electrical filter.

In Cine mode, “5600” is displayed when the daylight filter is selected. When the tungsten filter is selected, this column becomes blank.

In Custom mode, “5600” is displayed when 5600K is set to ON.

8 Optical filters

Displays the types of filters currently selected. The number (1, 2, 3, 4, or 5) indicates the ND filter, and the letter (A, B, C, D) is for the CC filter.

The letter E is displayed when 1/2ND filter is selected.

9 Gain value

Displays the video gain value (dB) of the video amplifier.

10 Shutter

The shutter setting is displayed with the shutter angle or frequency. For a shutter angle, ▲ is displayed at the left. The type of the display, angle (deg) or frequency (Hz), can also be switched on the <VF DISPLAY> page of the USER (OPERATION) menu (default: deg).

11 Tape remaining

The remaining time of the tape is roughly indicated in minutes when the recorder docked on the camera is in REC mode.

12 Recording mode

“REC” is displayed when the recorder docked on the camera is in REC mode.

13 F value

Indicates the lens f-stop (iris opening) value.

14 Self-diagnosis information

“CAM?” is displayed if an error is generated, e.g., on an internal board, and an error message appears in the message area.

This indication cannot be set to OFF.

For the error messages, see “Warning/Error Messages” (page 91).

15 Message area

Displays the status of auto setup, error messages, etc.

Setting the basic status indications

The conditions for displaying the basic status indications can be set on the <VF DISPLAY> page of the USER (OPERATION) menu.

<VF DISPLAY> page

<VF DISPLAY>		U01	
FPS	: ON	GAIN	: ON
EX	: ON	SHUTT	: ON
ZOOM	: OFF	UNIT	: deg
FOCUS	: OFF	BATT12	: OFF
ND	: ON	BATT24	: OFF
CC	: ON	REC	: OFF
5600K	: ON	TAPE	: OFF
IRIS	: ON		
WHITE	: OFF	MESSAG	: ALL

Item	Setting
FPS	Set to ON to obtain the frame rate indication ❶.
EX	Set to ON to obtain the lens extender indication ❷.
ZOOM	Set to ON to obtain the zoom position indication ❸.
FOCUS	Set to ON to obtain the focus position indication ❹.
ND	Set to ON to obtain the optical filter indications ❺.
CC	
5600K	Set to ON to obtain the 5600 indication ❻.
IRIS	Set to ON to obtain the F value indication ❼.
WHITE	Set to ON to obtain the white balance memory indication ❽.
GAIN	Set to ON to obtain the gain value indication ❾.
SHUTT	Set to ON to obtain the shutter indication ❿.
UNIT	Select the unit for the shutter indication. deg: Shutter angle (Default) Hz: Frequency
BATT12	Set to ON to obtain the battery indications ⓫.
BATT24	

Item	Setting
REC	Set to ON to obtain the recording mode indication ❶.
TAPE	Set to ON to obtain the tape remaining indication ❷.
MESSAG	Select the type of messages to be displayed in the message area ❸. ALL: To display all messages AT: To display Auto Setup information and higher WRN: To display warning messages and higher OFF: To display warning messages of the highest level only

3-6-2 Viewing the ABNORMAL <!> Display

Pressing the CANCEL/STATUS button calls the following ABNORMAL< ! > display, permitting you to check the items for which the setting is not in the normal condition. The display conditions can be set using the <'!' IND> page of the USER (OPERATION) menu.

ABNORMAL <!>	
IND	: 1
!CC	: B
!WHITE	: A
!5600K	: OFF
!SHUTT	: 360.0
!FAN	: MAX
!EXT	: OFF
!G-COMP	: ON

Setting the ABNORMAL<!> indications

Set the conditions for the abnormal indications on the <'!' IND> page of the USER (OPERATION) menu.

<'!' IND> page

<'!' IND>		U02	
	[IND]	[NORMAL]	
ND	: ON	1----	
CC	: ON	A----	
WHITE	: ON	P--	
5600K	: ON	OFF	
SHUTT	: ON	OFF	
FAN	: ON	AUTO1	
G-COMP	: ON		
EXT	: ON		

Indication of each item on the ABNORMAL< ! > display is turned on or off in the [IND] column.

Set the normal condition for each item in the [NORMAL] column.

If an item for which [IND] is set to ON becomes a condition other than that specified in the [NORMAL] column, the condition is indicated on the <'!' IND> page.

Item	Setting
ND	ND filter selection: 1, 2, 3, 4, 5 (combination allowed)
CC	CC filter selection: A, B, C, D, E (combination allowed)
WHITE	White balance memory selection: P, A, B (combination allowed)
5600K	Custom mode: 5600K ON/OFF Cine mode: ON for Tungsten, OFF for daylight
SHUTT	Shutter mode ON/OFF
FAN	Fan rotation mode selection: AUTO1, AUTO2, MIN. or MAX
G-COMP	Gain compensation mode (normal: OFF)
EXT	External sync mode (normal: OFF)

3-6-3 Viewing the FUNCTION (Format/Switch Function) Display

If you press the CANCEL/STATUS button with the ABNORMAL< ! > display on the screen, the display changes to the following FUNCTION display:

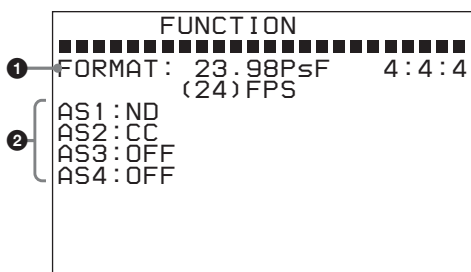

① Format indication

The current video format is displayed.

For details on the formats, see “3-14 Detailed Setting of the Video Format” (page 49).

② Assignable switch indication

The functions assigned to the assignable buttons and switch are indicated.

For functions that can be assigned, see “3-2-10 Allocation of Functions to the Assignable Buttons and Switch” (page 33).

3-6-4 Setting the Marker Indications

The various markers, such as the center marker and safety zone marker, can be displayed on the viewfinder and monitor screens.

Example: Center marker (entire cross)

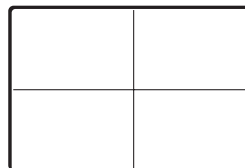

Example: Safety zone marker (90%)

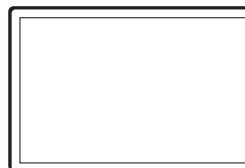

The <MARKER DISPLAY> page and <MARKER SETTING> page of the USER (OPERATION) menu allows you to switch the display of the markers on or off and to set the display conditions of the markers.

Activating/deactivating all the marker indications for each output

The <MARKER DISPLAY> page permits you to activate and deactivate the marker indications for each output.

<MARKER DISPLAY> page

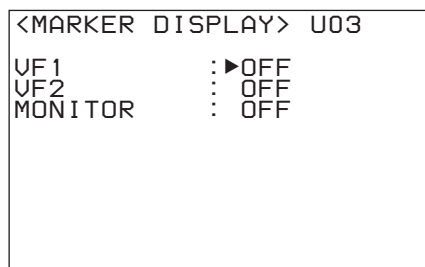

All the marker indications are deactivated for all the outputs at the factory.

Item	Setting
VF1	Turn all the markers on or off on the viewfinder connected to the VF1 connector.
VF2	Turn all the markers on or off on the viewfinder connected to the VF2 connector.
MONITOR	Turn all the markers on or off on the monitors connected via the MONITOR OUT connectors.

Specifying the markers to be displayed

For the outputs for which you activate the total marker indication on the <MARKER DISPLAY> page, select and adjust the marker(s) to be displayed on the next <MARKER SETTING> page.

<MARKER SETTING> page

```

<MARKER SETTING> U04
CENTER      : ▶ OFF  1
SAFETY     : OFF  90.0%
EFFECTIVE  : OFF
ASPECT     : OFF  4:3
VARIABLE   : --
SAFETY     : OFF  90.0%
MASK       : OFF  12
    
```

All the markers have been set to OFF at the factory.

Item	Setting
CENTER	Set to ON to display the center marker and select the type of the center marker. 1: Entire cross 2: Entire cross with a hole 3: Center 4: Center with a hole
SAFETY	Set to ON to display the safety zone marker and specify the range (80%, 90%, 92.5%, or 95%).
EFFECTIVE	Set to ON to display the effective pixel area.
ASPECT	Set to ON to display the aspect marker and specify the aspect: 16:9, 15:9, 14:9, 13:9, 4:3, VAR H, VAR V
VARIABLE	If you select VAR H or VAR V for ASPECT, set the H or V value. VAR H: 10 to 1920 VAR V: 10 to 1080
SAFETY	Set to ON to display the safety zone for the selected aspect marker, and specify the range.
MASK ¹⁾	Set to ON to make the areas outside the selected aspect marker dimmer, and select the mask level (1 to 15).

1) MASK is effective only for the signal fed to the VF2 connector.

3-6-5 Adjusting the Viewfinder Details

You can adjust the image on the viewfinder screen to obtain a clearer view, using the <VF DETAIL> page of the USER (OPERATION) menu. This adjustment does not affect the image being recorded.

<VF DETAIL> page

```

<VF DETAIL> U05
VF 1       : ▶ OFF
VF 2       : OFF
LEVEL      : 25%
CRISP      : 0
    
```

Item	Function
VF1	Turn the VF detail adjustment function on or off for the viewfinder connected to the VF1 connector.
VF2	Turn the VF detail adjustment function on or off for the viewfinder connected to the VF2 connector.
LEVEL	Set the level (0 to 100%) of the VF detail adjustment function.
CRISP	Set the noise crispening level (-99 to 99).

3-6-6 Setting the Zebra Indication

You can display a zebra pattern(s) on the viewfinder and monitor screen.

Zebra (default settings)

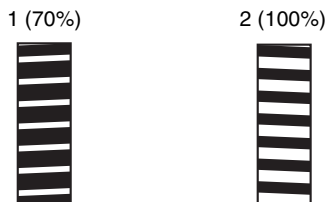

Setting the zebra indication is performed on the <ZEBRA> page of the USER (OPERATION) menu.

<ZEBRA> page

```

<ZEBRA> U06
VF1       : ▶ OFF
VF2       : OFF
MONITOR   : OFF
UBS       : OFF

ZEBRA TYPE : 1
ZEBRA1 LEVEL : 70%
              WIDTH : 10%
ZEBRA2     : 100%
    
```

Item	Function
VF1	Turn the zebra indication on the viewfinder connected to the VF1 connector on/off.
VF2	Turn the zebra indication on the viewfinder connected to the VF2 connector on/off.
MONITOR	Turn the zebra indication on the monitors connected to the MONITOR OUT connectors on/off.
VBS	Turn the zebra indication on a device connected via the REMOTE connector on/off.
ZEBRA TYPE	Select the zebra(s) to be displayed: 1, 2, or 1&2
ZEBRA1 LEVEL	Adjust the level (50 to 109%) of the zebra 1 indication (factory setting: 70%).
WIDTH	Adjust the width (0 to 30%) of the zebra 1 indication (factory setting: 10%).
ZEBRA2	Adjust the level (50 to 109%) of the zebra 2 indication (factory setting: 100%).

3-6-7 Setting the Cursor Indication

You can display a cursor on the viewfinder and monitor screen.

Example: Box cursor

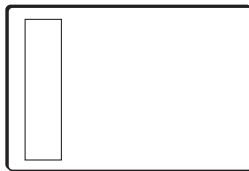

Setting the cursor indication is performed on the <CURSOR> page of the USER (OPERATION) menu.

<CURSOR> page

```

<CURSOR>           U07
VF1                 : OFF
VF2                 : OFF
MONITOR             : OFF

BOX/CROSS          : BOX
H POSITION           : 0
V POSITION           : 0
WIDTH              : 960
HEIGHT             : 540

```

Menu item	Function
VF1	Turn the cursor indication on the viewfinder connected to the VF1 connector on/off.
VF2	Turn the cursor indication on the viewfinder connected to the VF2 connector on/off.

Menu item	Function
MONITOR	Turn the cursor indication on the monitors connected to the MONITOR OUT connectors on/off.
BOX/CROSS	Select the type of the cursor to be displayed.
H POSITION	Adjust the horizontal position of the center (-960 to 960).
V POSITION	Adjust the vertical position of the center (-540 to 540).
WIDTH	Adjust the width (from the center to right or left side) of the cursor (16 to 1920).
HEIGHT	Adjust the height (from the center to top or bottom) of the cursor (16 to 1080).

3-6-8 Checking the Power Voltage

The settings of the NEAR END and END values to warn of low voltage of a power supply can be checked on the <BATTERY ALARM> page of the USER (OPERATION) menu.

<BATTERY ALARM> page

```

<BATTERY ALARM>  U16
DC IN (24V)       24.2V
TYPE: AC ADP
NEAR END         : (22.2)
END              : (21.6)

DC IN (12V)       12.8V
TYPE: AC ADP
NEAR END         : (11.1)
END              : (10.8)

```

Menu item	Indication
DC IN (24V)	Voltage of the 24-V power
TYPE	Select the type of the 24-V power source.
NEAR END	NEAR END value specified for the 24-V power source of the selected type
END	END value specified for the 24-V power source of the selected type
DC IN (12V)	Voltage of the 12-V power
TYPE	Select the type of the 12-V power source.
NEAR END	NEAR END value specified for the 12-V power source of the selected type
END	END value specified for the 12-V power source of the selected type

This page is intended for display only. You can only switch the type. If you want to change the values, use the <BATT ALARM SET> page of the MAINTENANCE menu.

3-7 Detailed Settings of the Switch Functions

By using the <SWITCH ASSIGN> page of the USER (OPERATION) menu displayed on the viewfinder/monitor screen, the operation mode of the MENU SEL/ENTER dial in addition to function assignment to the assignable buttons/switch that can also be made on the subdisplay.

<SWITCH ASSIGN> page

```

<SWITCH ASSIGN>  U14
AS1      : ▶ND
AS2      :  CC
AS3      :  OFF
AS4      :  OFF
RE_ROTATION: STD
  
```

Assigning functions to the assignable buttons/switch

When you position the pointer to any of the AS1 to AS4 lines and push on the MENU SEL/ENTER dial, the subpage to set the corresponding button/switch is displayed.

You can assign the same functions as those when you operate the subdisplay.

For the assignable functions, see “3-2-10 Allocation of Functions to the Assignable Buttons and Switch” (page 33).

Setting subpage for assignable button 1

```

        ASSIGN SW1      ESC
▶OFF
ND
CC
REC REVIEW
PB(UF)
VF709GAM
MONI709GAM
FAN MODE
  
```

The setting subpages for button 2 and 3 have the same layout as that for button 1.

Setting subpage for assignable switch 4

```

        ASSIGN SW4      ESC
▶OFF
AWB
BARS
TEST1
  
```

Position the pointer to the function to be assigned and push on the MENU SEL/ENTER dial.

Setting the operation mode of the MENU SEL/ENTER dial

You can reverse the operation corresponding to the directions of rotation of the MENU SEL/ENTER dial on the camera head and that on the assistant panel.

Setting	Operation
STD (default)	Clockwise rotation moves the pointer/cursor down or increases values on a menu/subdisplay page.
RVS	Clockwise rotation moves the pointer/cursor up or decreases values on a menu/subdisplay page.

3-8 Setting the Gain

If the gain of the video amplifier of this camera is to be switched using the gain switch of the RM-B150 Remote Control Unit, the gain values for the corresponding switch positions must be specified in advance.

Use the <GAIN ASSIGN> page of the USER (OPERATION) menu.

<GAIN ASSIGN> page

```

<GAIN ASSIGN>      U15
GAIN [L]: ▶ 0 dB
[M]: 6 dB
[H]: 12 dB
  
```

Menu item	Setting
GAIN [L]	Gain value corresponding to the L position of the gain switch.
GAIN [M]	Gain value corresponding to the M position of the gain switch.
GAIN [H]	Gain value corresponding to the H position of the gain switch.

Any of -3, 0, 3, 6, 9, or 12 dB can be set for each of the L, M, and H positions, in any sequence.

3-9 Detailed Shutter Settings

The Electronic Shutter function of this camera enables shooting with various shutter angles and shutter frequencies (speeds).

While the basic settings of the shutter can be made on the subdisplay, the <SHUTTER/FPS> page of the USER (PAINT) menu permits you to set the shutter while observing the shutter angles, the shutter frequencies, and the frame rates at a glance.

<SHUTTER/FPS> page

```

<SHUTTER/FPS>      U20
SHUTTER: ▶STEP
           [deg]   [Hz]
*STEP: 1  180.0   47.91
VAR      : 180.0   47.91

FRAME RATE : (24)FPS

COMPENSATION
ANGLE: OFF
GAIN : OFF
  
```

SHUTTER

To activate the Electronic Shutter, set to STEP or VARIABLE (ECS). An asterisk appears on the setting line of the selected Shutter mode.

STEP

When you use Step Shutter mode, select the step number. The shutter angle registered for the selected step is displayed in the [deg] column. The [Hz] column shows the equivalent frequency value according to the frame rate selected. The shutter speed will be [1/frequency] sec.

VAR

To use a value that has not been registered as a Step Shutter, select the desired value on this line.

FRAME RATE

Select the frame rate (number of frames per second) when a format with S is selected.

The selecting range depends on the formats, as follows:

Selected format	Selectable frame rates
S23.98PsF/S24PsF	1 to 24 FPS (frames per second)
S25PsF	1 to 25 FPS
S29.97PsF/S30PsF	1 to 30 FPS)
S50P	1 to 50 FPS
S59.94P/S60P	1 to 60 FPS

If a format that is not prefixed with S has been selected, a value is indicated in parentheses and cannot be changed.

COMPENSATION

Either mode can be activated. Simultaneous activation of both modes is not permitted.

- **ANGLE: Angle Compensation mode**

When you change the FPS setting with this mode set to OFF, the shutter frequency is compensated while maintaining the current shutter angle setting. If this mode is set to ON, the current shutter angle is compensated maintaining the current shutter frequency setting when you change the FPS setting. The video level is also maintained at a certain level. Set this mode to ON to reduce flicker at a specific frequency when you change the frame rate.

Notes

- With ANGLE ON, the frame rate cannot be changed to lower values if the shutter angle comes to near 0°, and it cannot be changed to higher values if the shutter angle comes to near 360°.
- When you activate Angle Compensation mode, the camera automatically enters Variable Shutter mode.

- **GAIN: Gain Compensation mode**

By setting this mode to ON at low FPS settings, you can obtain an image with motion blur if desired, and superior S/N ratio.

In addition, as the video level is maintained at a certain level even if the frame rate is changed, this mode may be useful when testing which FPS value yields the most desired motion blur effect.

Note

Care must be taken when shooting a high-contrast subject, as the dynamic range (latitude) may be degraded to $1/2$ at maximum depending on the selected video format or FPS.

3-10 Resuming the Standard Conditions

The <OPERATOR FILE> page of the USER (OPERATION) menu permits you to return the operation items (those contained on pages U02 to U16 of the factory-preset USER menu) you changed to the factory-set statuses.

<OPERATOR FILE> page

```

<OPERATOR FILE>  U17
  READ  (MS →CAM)
  WRITE (CAM→MS )
  ►PRESET

FILE ID:
CAM CODE
DATE
  
```

Position the pointer to PRESET and push on the MENU SEL/ENTER dial. The operation items return to the statuses stored in the operator file.

For details on the operator file, see “Chapter 5 Storage and Retrieval of User Setting Data”.

3-11 Selecting the Gamma

You can use User gamma you create in addition to the built-in Standard gamma and Hyper gamma. Use the <GAMMA> page of the USER (PAINT) menu for gamma operations.

<GAMMA> page

<GAMMA>	U19			
LEVEL	: [R]	[G]	[B]	[M]
	: 0	0	0	0
COARSE	: 0.45			
TABLE	: ▶STANDARD			
	: 5 (ITU-R709)			
GAMMA	: ON			
TEST	: OFF			

3-11-1 Using the Standard Gamma

The standard gamma is intended to be used for on-the-spot creation of video materials, eliminating the need for post-production processing.

When STANDARD is selected on the first line of TABLE of the <GAMMA> page, you can select from among the following standard gamma curves:

Gamma table No.	Gamma curve
1	equivalent to SD ENG camcorder
2	equivalent to 4.5-times gain
3	equivalent to 3.5-times gain
4	equivalent to SMPTE-240M
5	equivalent to ITU-R709
6	equivalent to 5.0-times gain

It is recommended to use the No. 5 (ITU-R709) curve in normal use.

As ITU-R709 provides 4.5-times gain around the black, select the No. 6 (x5) curve when better tonal reproduction is required.

3-11-2 Using the Hyper Gamma

The Hyper Gamma is a set of transfer functions designed to be easy to use as previous gamma curve functions and to realize a natural tone in high contrast scenes by taking full advantage of the capacity and wide dynamic range of the CCD sensor.

- 1 Select HYPER on the first line of TABLE on the <GAMMA> page, and select the hyper gamma table most suitable to the shooting conditions and purpose.

	Effective for shooting in low-light scenes for better tonal reproduction of low-key areas (assuming that -3 dB gain is used)	Effective for shooting from low-light to high-contrast scenes (assuming that 0 dB gain is used)
Clipping the upper limit to around 100%	Hyper Gamma 1	Hyper Gamma 2
Clipping the upper limit to around 109%	Hyper Gamma 3	Hyper Gamma 4

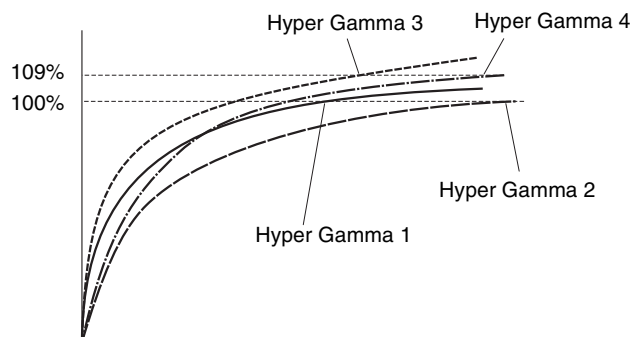

These curves are equivalent to those built into the HDW-F900R HD Camcorder.

- 2 Call the <WHITE CLIP> page of the PAINT menu and adjust the white clip level to fit the selected hyper gamma.

3-11-3 Using the User Gamma

User gamma curves are initialized with S-LOG at the factory.

S-LOG is a set of data optimized to record image information as digital data materials by using the entire dynamic range of this camera. It assumes digital processing in post production.

You can also create a desired gamma table, using a personal computer on which software CvpFileEditor™¹⁾ has been installed and load the table into the camera via a "Memory Stick."

When a user gamma table is selected, control of gamma (LEVEL or ON/OFF) may become disabled, depending on

data of the table. This is because the gamma and knee are compulsorily fixed when creating the gamma curve.

1) CvpFileEditor is a trademark of Sony Corporation.

To select the user gamma

- 1 To use the gamma table you have created, load it into the camera.

Load the gamma table data via a “Memory Stick” using the <USER GAMMA> page of the FILE menu in Custom mode.

<USER GAMMA> page

```

<USER GAMMA>      F04 TOP
  →READ (MS →CAM)

FILE ID
CAM CODE
DATE
  
```

For details on file operations, see “Chapter 5 Storage and Retrieval of User Setting Data”.

- 2 Select the user gamma.

Select USER on the first line of TABLE on the <GAMMA> page of the USER (PAINT) menu and display the desired user gamma.

CvpFileEditor

The F23 supports CvpFileEditor Version 3.0 or later. If the version of your CvpFileEditor is an earlier version, you can download the software from the “eCSite,” the site for downloading business and professional software from Sony Corporation.

If you have not registered at “eCSite,” access the following URL and register.

<https://www.ecspert.sony.biz/ecsite/center/registUserInfo?action=regulationsDirect>

For detailed information on how to install the software, refer to the manual for CvpFileEditor, available from the above site.

3-12 Setting the Fan Operation Mode

The operation mode of the built-in fans can be changed according to the ambient temperature or the operation mode of the recorder.

Using the <OTHERS 1> page on the USER (MAINTENANCE) menu, you can select the same modes as those selectable on the subdisplay (page 32).

<OTHERS 1> page

```

<OTHERS 1>      U21
FAN MODE          :▶AUTO1
CAM BARS          : OFF
IMAGE INVERT     : OFF
  
```

Select the FAN MODE setting.

Setting	Mode
AUTO1	Standard Rotation mode
AUTO2	Mode equivalent to AUTO1 when the recorder is in REC mode, and mode equivalent to MIN in other conditions
MIN	Minimum Rotation mode
MAX	Maximum Rotation mode

3-13 Inverting the Camera Picture

The image-inversion function allows you to cancel the image inversion phenomena that occurs when a cine-lens converter is used.

Use the <OTHERS 1> page on the USER (MAINTENANCE) menu to access to this function.

<OTHERS 1> page

<OTHERS 1>	U21
FAN MODE	: AUTO1
CAM BARS	: OFF
IMAGE INVERT	: ►OFF

Set IMAGE INVERT to ON to activate the image-inversion function. The upside of the picture comes down, swapping the right and left.

3-14 Detailed Setting of the Video Format

You can select various video formats according to that of the video recorder used in combination.

Available formats

Frame rate	Signal format	Frame rate	Signal format
23.98PsF	4:2:2 YCbCr	29.97PsF	4:2:2 YCbCr
23.98PsF	4:4:4 RGB	29.97PsF	4:4:4 RGB
S23.98PsF	4:2:2 YCbCr	S29.97PsF	4:2:2 YCbCr
S23.98PsF	4:4:4 RGB	S29.97PsF	4:4:4 RGB
24PsF	4:2:2 YCbCr	50P	4:2:2 YCbCr
24PsF	4:4:4 RGB	S50P	4:2:2 YCbCr
S24PsF	4:2:2 YCbCr	S60P	4:2:2 YCbCr
S24PsF	4:4:4 RGB	59.94P	4:2:2 YCbCr
25PsF	4:2:2 YCbCr	S59.94P	4:2:2 YCbCr
25PsF	4:4:4 RGB	59.94I	4:2:2 YCbCr
S25PsF	4:2:2 YCbCr	59.94I	4:4:4 RGB
S25PsF	4:4:4 RGB	50I	4:2:2 YCbCr
S30PsF	4:2:2 YCbCr	50I	4:4:4 RGB
S30PsF	4:4:4 RGB		

You can confirm the format being selected on the FUNCTION display (page 41).

Any three of above formats of highest need can be registered to be selected on the subdisplay.

For format selection on the subdisplay, see “3-2-3 Selection of Video Formats” (page 30).

Using the <OUTPUT FORMAT> page of the MAINTENANCE menu enables selection of the mainly used format in interface with the SRW-1 HD Portable Digital Recorder.

Frame frequency of 23.98PsF and signal format of 4:4:4 RGB have been selected at the factory.

Changing the format

Referring to the procedure mentioned in “2-8 Setting the Built-in Clock” (page 25), select MAINTENANCE menu on the TOP MENU screen and call up the <OUTPUT FORMAT> page.

For details on menu operations, see “4-2 Basic Menu Operations” (page 52).

<OUTPUT FORMAT> page of MAINTENANCE menu

```
<OUTPUT FORMAT>  M07 TOP
CURRENT  23.98P5F 4:4:4
NEXT
SCAN      :→PROGRESSIVE
FRAME     : 23.98
SIGNAL    : 4:4:4 RGB
SELECT FPS: OFF
          SET RORMAT
```

CURRENT

The current format is displayed.

Specify the desired format, using the lines under NEXT.

SCAN

Select the scan mode: PROGRESSIVE or INTERLACE.

FRAME

Select the frame rate. When you select INTERLACE for the scan mode, select 29.97 to specify 59.94I or select 25 to specify 50I.

SIGNAL

Select the signal format.

SELECT FPS

Set to ON to use the Select FPS function.

For details on the Select FPS function, refer to the Operation Manual of the SRW-1 HD Portable Digital Recorder.

When the settings are completed, position the pointer at SET FORMAT and push on the MENU SEL/ENTER dial. The format is changed, and the new format is displayed on the CURRENT line.

Notes

- If you select the format in invalid combination (e.g., 60P and 4:4:4), SET FORMAT is displayed in parentheses, and the format cannot be changed.
- If the recorder refuses the format change by the above procedure, the message “UNSUPPORTED FORMAT” is displayed for three seconds.

Menu Configuration and Detailed Settings

Chapter

4

4-1 Menu Configuration

In addition to the subdisplay pages, the menus displayed on the viewfinder enable various detailed settings of the camera.

The available menus are:

USER menu

This menu can include menu pages selected from among the OPERATION, PAINT, MAINTENANCE, NETWORK, FILE, and DIAGNOSIS menus, for your convenience. Changing, adding, and deleting pages can be performed with the USER MENU CUSTOMIZE menu. The following pages are included on the factory-set USER menu:

Menu page title	USER menu No.	Source menu/Page No.
<VF DISPLAY>	U01	OPERATION 01
<! IND>	U02	OPERATION 02
<MARKER DISPLAY>	U03	OPERATION 03
<MARKER SETTING>	U04	OPERATION 04
<VF DETAIL>	U05	OPERATION 05
<ZEBRA>	U06	OPERATION 06
<CURSOR>	U07	OPERATION 07
<MONITOR OUTPUT>	U08	OPERATION 08
<PB MONI GAMMA>	U09	OPERATION 09
<PB MIX SETTING>	U10	OPERATION 10
<CHAR/MARK MIX>	U11	OPERATION 11
<SHUTTER ASSIGN>	U12	OPERATION 12
<ASSISTANT PNL>	U13	OPERATION 13
<SWITCH ASSIGN>	U14	OPERATION 14
<GAIN ASSIGN>	U15	OPERATION 15
<BATTERY ALARM>	U16	OPERATION 16
<OPERATOR FILE>	U17	OPERATION 17
<LENS FILE>	U18	OPERATION 18
<GAMMA>	U19	PAINT P03

Menu page title	USER menu No.	Source menu/Page No.
<SHUTTER/FPS>	U20	PAINT P13
<OTHERS 1>	U21	MAINTENANCE M13

For the items on each page, see the corresponding source menu page in the table in “4-3 Menu List” (page 55).

USER MENU CUSTOMIZE menu

This menu allows you to edit the USER menu.

For details, see “4-4 Editing the USER Menu” (page 75).

ALL menu

This menu permits you to control all items of the OPERATION, PAINT, MAINTENANCE, NETWORK, FILE, and DIAGNOSIS menus as a single menu.

OPERATION menu

This menu contains items for camera operators to operate the camera. It mainly permits viewfinder and switch settings.

For the pages and included items of the OPERATION menu, see “4-3-1 OPERATION Menu” (page 55).

PAINT menu

This menu contains items for making detailed image adjustments while using a waveform monitor to monitor the waveforms output from the camera.

For the pages and included items of the PAINT menu, see “4-3-2 PAINT Menu” (page 60).

MAINTENANCE menu

This menu contains items for performing camera maintenance operations, such as changing the system or setting infrequently used “paint” items.

For the pages and included items of the MAINTENANCE menu, see “4-3-3 MAINTENANCE Menu” (page 65).

NETWORK menu

This menu is for enabling the camera to be operated from a distance via a network cable, e.g., using the MSU-900/950 Master Setup Unit.

For the pages and included items of the NETWORK menu, see “4-3-4 NETWORK Menu” (page 70).

For the settings to use the MSU-900/950, see “Using the MSU-900/950” (page 88).

FILE menu

This menu is for performing file operations, such as storing/retrieving various menu setting data.

For the pages and included items of the FILE menu, see “4-3-5 FILE Menu” (page 71).

For details on files and file operations, see “Chapter 5 Storage and Retrieval of User Setting Data”.

DIAGNOSIS menu

This menu enables you to confirm the self-diagnostic information.

For the pages and included items of the DIAGNOSIS menu, see “4-3-6 DIAGNOSIS Menu” (page 74).

4-2 Basic Menu Operations

For menu operations, use the VF MENU/DISPLAY button, MENU SEL/ENTER dial, and CANCEL/STATUS button on the side panel of the camera head or those on the assistant panel connected to the CONTROL PANEL connector.

Turn the MENU SEL/ENTER dials for MENU SEL, or push on it for ENTER.

Operations are possible both on the side panel of the camera head and on the assistant panel.

However, the LOCK switches are active only on the corresponding panels. If you wish to inhibit operations from either panel, set the LOCK switch of that panel to ON.

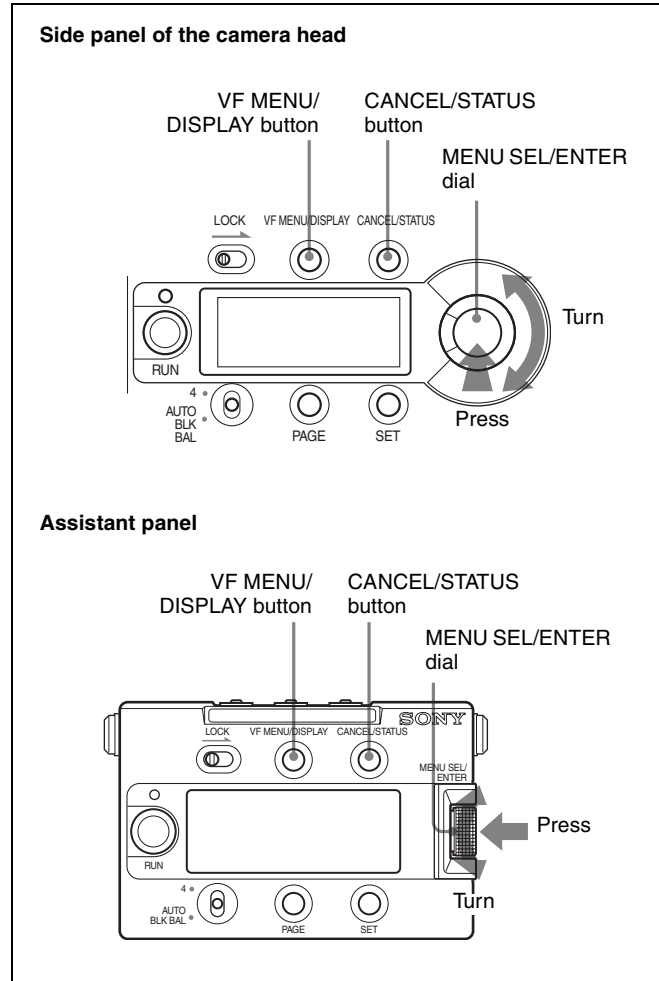

Note

When the subdisplay is in Data Change mode (? symbol shown at the right corner), menu operations on the viewfinder or monitor screen are disabled.

For settings on the subdisplay, see “3-2 Basic Settings with the Subdisplay” (page 27).

4-2-1 Displaying Setting Pages

Press the VF MENU/DISPLAY button.

The last operated menu page is displayed. (If this is your first menu operation, the CONTENTS page of the USER menu is displayed.)

The pointer on the menu screen is ► in Cine mode and → in Custom mode.

Selecting menu pages from the TOP MENU screen

If you press the VF MENU/DISPLAY button while holding the MENU SEL/ENTER dial pressed, “TOP” is displayed at the upper right corner of the screen.

Example

```

<VF DETAIL>                05→TOP
VF 1      : OFF
VF 2      : OFF
LEVEL    : 25%
    
```

Press the CANCEL/STATUS button, or move the pointer to “TOP” and push on the MENU SEL/ENTER dial. This displays the TOP MENU screen, which lists the available menus, and you can select the menus on this screen.

TOP MENU screen

```

<TOP MENU>
►USER
USER MENU CUSTOMIZE
ALL
•OPERATION
•PAINT
•MAINTENANCE
•NETWORK
•FILE
•DIAGNOSIS
    
```

1 Turn the MENU SEL/ENTER dial to align the pointer with the desired menu indication.

2 Push on the MENU SEL/ENTER dial.

The CONTENTS page or the last operated page of the selected menu is displayed.

To return to the TOP MENU screen

Press the CANCEL/STATUS button, or move the pointer to “TOP” and press the MENU SEL/ENTER dial. The TOP MENU screen is restored.

To disable the “TOP” indication

Turn the power once off then on again, or push on the MENU SEL/ENTER dial while holding the CANCEL/STATUS button pressed. This disables the TOP selection. Each time you turn the power off, the TOP selection is disabled, setting the camera to a state where only the USER menu (page 51) can be accessed.

You can arrange the USER menu so that it includes pages and items you use most frequently.

See “4-4 Editing the USER Menu” (page 75).

Selecting a page from a CONTENTS page

CONTENTS page (e.g.: USER menu)

Pointer

If the screen can be scrolled, arrows will indicate the direction of scrolling.

```

CONTENTS    U00
01.<VF DISPLAY>
02.<'I' IND>
03.<MARKER DISPLAY>
04.<MARKER SETTING>
05.<VF DETAIL>
06.<ZEBRA>
07.<CURSOR>
08.<MONITOR OUTPUT>
09.<PB/MONI GAMMA>
10.<PB MIX SETTING>
    
```

Turn the MENU SEL/ENTER dial to align the pointer with the desired page indication then push on the MENU SEL/ENTER dial.

The selected page is displayed.

Page number

```

<VF DETAIL>                →05
VF 1      : OFF
VF 2      : OFF
LEVEL    : 25%
CRISP    : 0
    
```

Changing the displayed page

1 Check that the pointer is located at the left of the page number then push on the MENU SEL/ENTER dial.

The pointer changes to a flashing question mark (? symbol).

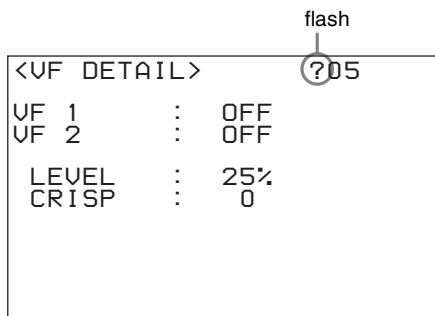

2 Turn the MENU SEL/ENTER dial to flip through the pages.

3 When the desired page is displayed, push on the MENU SEL/ENTER dial.

The “?” symbol will change back to the pointer (→ or ►), and operations with the displayed page will be enabled.

4-2-2 Setting the Menu Items

If a “?” symbol is flashing at the left of the page number, push on the MENU SEL/ENTER dial to change it to the pointer (→ or ►). Making settings on the displayed page is then enabled.

Changing the setting

1 Turn the MENU SEL/ENTER dial to align the pointer with the desired item.

2 Push on the MENU SEL/ENTER dial.

The pointer will change to a flashing “?” symbol.

3 Turn the MENU SEL/ENTER dial to change the setting value.

When the knob is rotated quickly, the values will change quickly; when rotated slowly, the values will change slowly.

To reset a changed value

If you press the CANCEL/STATUS button before pushing on the MENU SEL/ENTER dial, the setting will be returned to its previous value.

To interrupt settings

Press the VF MENU/DISPLAY button to turn off the menu screen display.

The setting operation can be restarted by setting the VF MENU/DISPLAY button again.

4 Push on the MENU SEL/ENTER dial.

The “?” symbol will change back to the pointer (→ or ►), and the new setting will be registered.

5 To change other setting items on the same menu page, repeat steps **1** through **4**.

Specifying a character string

When you push on the MENU SEL/ENTER dial with the pointer pointing to an item for which a character string, such as a file ID, is to be specified, a cursor and the list of selectable characters are displayed.

The displayed cursor can be moved by rotating the MENU SEL/ENTER dial.

1 Move the cursor to the position where you wish enter a character then push on the MENU SEL/ENTER dial.

Another cursor appears on the character list.

2 Position the cursor to the character to be entered and push on the MENU SEL/ENTER dial.

Repeat steps **1** and **2**.

By selecting INS on the line below the character list, you can enter a space at the cursor position.

Selecting DEL deletes the character at the cursor position.

You can return to step **1** without changing the character by selecting RET.

If you enter the permitted maximum number of characters (up to the stop mark at the right end of the line), the cursor moves to ESC on the line below the character list.

To register the new string you have set, select END and push on the MENU SEL/ENTER dial.

To restore the previous string, select ESC and push on the MENU SEL/ENTER dial.

Ending menu operations

Press the VF MENU/DISPLAY button.

4-3 Menu List

This section shows the menus to be displayed on the viewfinder in tables.

- For the pages that have been registered in the USER menu at the factory, the USER menu page numbers are indicated in parentheses in the No. column of the tables.

- A CONTENTS page (numbered 00) is also provided for each menu.

4-3-1 OPERATION Menu

The OPERATION menu items can be set in both Cine and Custom modes.

Execute by ENTER. Execute by pushing on the MENU SEL/ENTER dial.

OPERATION menu					
Page title & purpose	No.	Item	Default	Settings	Remarks
<VF DISPLAY> Setting the basic status indications (page 39)	01 (U01)	FPS	ON	ON, OFF	
		EX	ON	ON, OFF	
		ZOOM	OFF	ON, OFF	
		FOCUS	OFF	ON, OFF	
		ND	ON	ON, OFF	
		CC	ON	ON, OFF	
		5600K	OFF	ON, OFF	
		IRIS	OFF	ON, OFF	
		WHITE	OFF	ON, OFF	
		GAIN	ON	ON, OFF	
		SHUTT	ON	ON, OFF	
		UNIT	deg	deg, Hz	
		BATT12	ON	ON, OFF	
		BATT24	OFF	ON, OFF	
		REC	ON	ON, OFF	
		TAPE	OFF	ON, OFF	
MESSAG	ALL	ALL, AT, WRN, OFF		ALL: To display all messages AT: To display Auto Setup information and higher WRN: To display warning messages and higher OFF: To display warning messages of the highest level only	

OPERATION menu					
Page title & purpose	No.	Item	Default	Settings	Remarks
<'! IND> Setting the ABNORMAL <! > display	02 (U02)	ND	[IND] ON	ON, OFF	[IND]: Set whether to be included in the '!' indications on the ABNORMAL <! > display [NORMAL]: Specify the conditions under which the '!' indication is not to be displayed even if [IND] is ON. (By specifying the standard or normal conditions here, non-standard or abnormal conditions can be found with the '!' indication.) e.g.: With the default setting of ND, the '!' indication is displayed when an ND filter other than 1 is selected.
			[NORMAL] 1 - - - -	1, 2, 3, 4, 5 (combination allowed)	
		CC	[IND] ON	ON, OFF	
			[NORMAL] A - - - -	A, B, C, D, E (combination allowed)	
		WHITE	[IND] ON	ON, OFF	
			[NORMAL] P - -	P, A, B (combination allowed)	
		5600K	[IND] ON	ON, OFF	
			[NORMAL] OFF	ON, OFF	
		SHUTT	[IND] ON	ON, OFF	
			[NORMAL] OFF	ON, OFF	
		FAN	[IND] ON	ON, OFF	
			[NORMAL] AUTO1	AUTO1, AUTO2, MIN, MAX	
G-COMP	[IND] ON	ON, OFF			
		The normal condition is fixed to OFF.			
EXT	[IND] ON	ON, OFF			
		The normal condition is fixed to OFF.			
<MARKER DISPLAY> Turning the marker display on/off	03 (U03)	VF1	OFF	ON, OFF	Except MASK
		VF2	OFF	ON, OFF	
		MONITOR	OFF	ON, OFF	Except MASK
<MARKER SETTING> Specifying markers	04 (U04)	CENTER	OFF	ON, OFF	1: Entire cross 2: Entire cross with a hole 3: Center 4: Center with a hole
			1	1, 2, 3, 4	
		SAFETY	OFF	ON, OFF	
			90.0%	80.0%, 90.0%, 92.5%, 95.0%	
		EFFECTIVE	OFF	ON, OFF	
		ASPECT	OFF	ON, OFF	
			4:3	16:9, 15:9, 14:9, 13:9, 4:3, VAR H, VAR V	
		VARIABLE	1440	10 to 1920	
			1016	10 to 1080	
		SAFETY	OFF	ON, OFF	For the safety marker in Aspect mode
			90.0%	80.0%, 90.0%, 92.5%, 95.0%	
		MASK	OFF	ON, OFF	
12	0 to 15		Set the level to darken the areas outside the aspect marker.		

OPERATION menu					
Page title & purpose	No.	Item	Default	Settings	Remarks
<VF DETAIL> Adjusting the detail on the viewfinders	05 (U05)	VF1	ON	ON, OFF	
		VF2	ON	ON, OFF	
		LEVEL	25%	0 to 100%	
		CRISP	0	-99 to +99	
<ZEBRA> Setting the zebra	06 (U06)	VF1	OFF	ON, OFF	
		VF2	OFF	ON, OFF	
		MONITOR	OFF	ON, OFF	
		VBS	OFF	ON, OFF	
		ZEBRA TYPE	1	1, 2, 1&2	
		ZEBRA1 LEVEL	70%	50 to 109%	
		WIDTH	10%	0 to 30%	
		ZEBRA2	100%	50 to 109%	
<CURSOR> Setting the cursor	07 (U07)	VF1	OFF	ON, OFF	
		VF2	OFF	ON, OFF	
		MONITOR	OFF	ON, OFF	
		BOX/CROSS	BOX	BOX, CROSS	
		H POSITION	0	-960 to 960	
		V POSITION	0	-540 to 540	
		WIDTH	960	16 to 1920	
		HEIGHT	540	16 to 1080	
<MONITOR OUTPUT> Setting the monitor output	08 (U08)	COLOR OUTPUT	COLOR	COLOR, R, G, B	
		MONI HD-SDI	MONI	MONI, VF1, VF2	
		TEST OUT	VBS	VBS, VF2, REF-THRU, FRAME	
		RM VIDEO	VBS	VBS, VF2	
<PB/MONI GAMMA> Setting the gamma of the playback picture/monitor picture	09 (U09)	MONI GAMMA ENABLE	OFF	ON, OFF	
		PB	VF OFF	OFF, ON, AUTO	
			MONI OFF	OFF, ON, AUTO	
			VBS OFF	OFF, ON, AUTO, (OFF)	(OFF): If either VF or MONI or both is/are R709 (cannot be changed)
		PB MIX	VF OFF	OFF, ON,	
			MONI OFF	OFF, ON,	
			VBS OFF	OFF, ON, (OFF)	(OFF): If either VF or MONI or both is/are R709 (cannot be changed)
		MONITOR GAMMA	VF OFF	OFF, R709, (OFF)	OFF: The same gamma as the main line R709: ITU-R709 (OFF): If MONI GAMMA ENABLE OFF (cannot be changed) (R709): If MONI GAMMA ENABLE ON (cannot be changed)
			MONI OFF	OFF, R709, (OFF)	
			VBS OFF	OFF, (R709), (OFF)	

OPERATION menu					
Page title & purpose	No.	Item	Default	Settings	Remarks
<PB MIX SETTING> Setting for mixing the playback picture	10 (U10)	MIX TYPE	MIX	MIX, WIPE	
		MIX			
		DIRECTION	CAM	CAM, PB	
		MODE	Y-MIX	Y-MIX, WIRE(W), WIRE(B)	
		LEVEL	80%	0 to 80%	
		WIPE			
		LAYOUT	HOR	HOR, VERT	
		PB POSITION	HOR: RIGHT VERT: BOTTOM	HOR: RIGHT, LEFT VERT: BOTTOM, TOP	
<CHAR/MARK MIX> Turning the character/marker ON/OFF	11 (U11)	CHAR	VF1 ON	ON, OFF	Character superimposing ON/OFF
			VF2 --	ON (fixed)	
			MONI ON	ON, OFF	
			VBS OFF	ON, OFF	
		MARKER	VF1 OFF	ON, OFF	Markers ON/OFF
			VF2 OFF	ON, OFF	
			MONI OFF	ON, OFF	
		CURSOR	VF1 OFF	ON, OFF	Cursor ON/OFF
			VF2 OFF	ON, OFF	
			MONI OFF	ON, OFF	
		ZEBRA	VF1 OFF	ON, OFF	Zebra ON/OFF
			VF2 OFF	ON, OFF	
			MONI OFF	ON, OFF	
			VBS OFF	ON, OFF	
		VF GATE MARKER	OFF	ON, OFF	
		<SHUTTER ASSIGN> Setting the step shutter values	12 (U12)	STEP	
1	360.0			360.0 to 4.2	
2	216.0			360.0 to 4.2	
3	180.2			360.0 to 4.2	
4	172.5			360.0 to 4.2	
5	150.1			360.0 to 4.2	
6	145.0			360.0 to 4.2	
7	107.8			360.0 to 4.2	
8	89.9	360.0 to 4.2			

OPERATION menu					
Page title & purpose	No.	Item	Default	Settings	Remarks
<ASSISTANT PNL> Registering the formats to be selected on the assistant panel	13 (U13)	FORMAT 1	23P 444	NO ASSIGN, 23P 444, S23P 444, 24P 444, S24P 444, 25P 444, S25P 444, 29P 444, S29P 444, S30P 444, 50I 444, 59I 444, 23P 422, S23P 422, 24P 422, S24P 422, 25P 422, S25P 422, 29P 422, S29P 422, S30P 422, 50P 422, S50P 422, 59P 422, S59P 422, S60P 422, 50I 422, 59I 422	Register the formats to be selected on the subdisplay. Select from among the formats displayed on the corresponding <FORMAT SEL> subpage.
		FORMAT 2	S23P 444	Same as above	
		FORMAT 3	S59P 444	Same as above	
<SWITCH ASSIGN> Setting the functions of the assignable buttons and switch	14 (U14)	AS1	ND	OFF, ND, CC, REC REVIEW, PB(VF), VF709GAM, MONI709GAM, FAN MODE	Select from among the functions displayed on the corresponding subpage.
		AS2	CC		
		AS3	OFF		
		AS4	OFF	OFF, AWB, BARS, TEST1	
		RE - ROTATION	STD	STD, RVS	
<GAIN ASSIGN> Specifying the gain switch settings	15 (U15)	GAIN	[L] 0 dB	-3, 0, 3, 6, 9, 12 dB	Assign the values for the gain switch of the RM-B150.
			[M] 6 dB	-3, 0, 3, 6, 9, 12 dB	
			[H] 12 dB	-3, 0, 3, 6, 9, 12 dB	
<BATTERY ALARM> Confirming the operating power voltage	16 (U16)	DC IN (24V)			
		TYPE	AC ADP	BATT1, BATT2, AC ADP	
		NEAR END	(22.2)		display only (Setting is achieved using the MAINTENANCE menu.)
		END	(21.6)		display only (Setting is achieved using the MAINTENANCE menu.)
		DC IN (12 V)			
		TYPE	AC ADP	BATT1, BATT2, AC ADP	
		NEAR END	(11.1)		display only (Setting is achieved using the MAINTENANCE menu.)
END	(10.8)		display only (Setting is achieved using the MAINTENANCE menu.)		

OPERATION menu					
Page title & purpose	No.	Item	Default	Settings	Remarks
<OPERATOR FILE> Operating the Operator file	17 (U17)	READ (MS→CAM)		Execute by ENTER.	To read the operator file from a "Memory Stick"
		WRITE (CAM→MS)		Execute by ENTER.	To write the current settings of the operator file items to a "Memory Stick"
		PRESET		Execute by ENTER.	To set the operator file items to the preset values in internal memory
		FILE ID		alphanumerics (max.14 characters)	Enter a comment for the operator file to be written to a "Memory Stick." See "Specifying a character string" (page 54).
		CAM CODE		Camera code	display only
		DATE			display only
<LENS FILE> Operating the lens files	18 (U18)	FILE	1	1 to 32	
			No Offset	Lens file name	display only
			F1.7	F1.0 to F3.4	display only
		CENTER MARKER			To set and store the center marker position: H POS: Increasing the value moves it to the right. V POS: Increasing the value moves it downwards.
		H POS	0	-20 to +20	
		V POS	0	-20 to +20	
		STORE		Execute by ENTER.	

4-3-2 PAINT Menu

: Valid in Custom mode only (Switch settings, such as ON/OFF, are fixed to the default statuses in Cine mode.)

: Valid in both Cine and Custom modes

Execute by ENTER. : Execute by pushing on the MENU SEL/ENTER dial.

PAINT menu					
Page title & purpose	No.	Item	Default	Settings	Remarks
<SW STATUS> Glancing and switching the paint functions on/off	P01	FLARE	OFF	ON, OFF	Fixed to OFF in Cine mode
		GAMMA	ON	ON, OFF	Fixed to ON in Cine mode
		BLK GAM	OFF	ON, OFF	Fixed to OFF in Cine mode
		KNEE	OFF	ON, OFF	Fixed to OFF in Cine mode
		WHT CLIP	OFF	ON, OFF	Fixed to OFF in Cine mode
		DETAIL	OFF	ON, OFF	Fixed to OFF in Cine mode
		LVL DEP	OFF	ON, OFF	Fixed to OFF in Cine mode
		SKIN DTL	OFF	ON, OFF	Fixed to OFF in Cine mode
		MATRIX	OFF	ON, OFF	Fixed to OFF in Cine mode
5600K	OFF	ON, OFF			

PAINT menu					
Page title & purpose	No.	Item	Default	Settings	Remarks
<VIDEO LEVEL> Adjusting the various video balance	P02	WHITE	[R] [G] [B] [M] 0 0 0	-99 to +99	R, G, B, and M (master) values can be independently set. (M cannot be set for WHITE or FLARE.) V MOD: To adjust the vertical shading caused by the lens
		BLACK	0 0 0 0	-99 to +99	
		FLARE	0 0 0	-99 to +99	
		GAMMA	0 0 0 0	-99 to +99	
		V MOD	0 0 0 0	-99 to +99	
		FLARE	OFF	ON, OFF	Fixed to OFF in Cine mode
		V MOD	ON	ON, OFF	Fixed to ON in Cine mode
		TEST	OFF	OFF, TEST1, TEST2	
<GAMMA> Adjusting the gamma	P03 (U19)	LEVEL	[R] [G] [B] [M] 0 0 0 0	-99 to +99	R, G, B, and M (master) values can be independently set.
		COARSE	0.45	0.35 to 0.90 (0.05 steps)	Fixed to 0.45 when HYPER GAMMA or USER GAMMA is selected
		TABLE	USER	STANDARD, HYPER GAMMA, USER	
			1	STANDARD 1: equivalent to a camcorder 2: 4.5-times gain 3: 3.5-times gain 4: equivalent to SMPTE-240M 5: equivalent to ITU-R709 6: 5.0-times gain HYPER GAMMA 1: H110-1Q 2: H110-2Q 3: H110-3Q 4: H110-4Q USER GAMMA 1: S-LOG 2: S-LOG 3: S-LOG 4: S-LOG 5: S-LOG	<i>For details, see "3-11 Selecting the Gamma" (page 47).</i>
		GAMMA	ON	ON, OFF	Fixed to ON in Cine mode
		TEST	OFF	OFF, TEST1, TEST2	
<BLACK GAMMA> Adjusting the contrast near black	P04	LEVEL	[R] [G] [B] [M] 0 0 0 0	-99 to +99	R, G, B, and M (master) values can be independently set.
		RANGE	HIGH	LOW, L.MID, H.MID, HIGH	
			OFF	ON, OFF	
TEST	OFF	OFF, TEST1, TEST2			
<SATURATION> Adjusting the color saturation	P05	SATURATION	0	-99 to +99	
			OFF	ON, OFF	
		LOW KEY SAT	0	-99 to +99	
		RANGE	HIGH	LOW, L.MID, H.MID, HIGH	
			OFF	ON, OFF	
TEST	OFF	OFF, TEST1, TEST2			

PAINT menu					
Page title & purpose	No.	Item	Default	Settings	Remarks
<KNEE> Adjusting the compression for high-luminance areas	P06	K POINT	[R] [G] [B] [M] 0 0 0 0	-99 to +99	R, G, B, and M (master) values can be independently set. K POINT: To adjust the point to apply the change K SLOPE: To adjust the slope of compression Absolute values are displayed in ABS mode except for M (master).
		K SLOPE	0 0 0 0	-99 to +99	
		KNEE	OFF	ON, OFF	
		KNEE MAX	OFF	ON, OFF	
		KNEE SAT	0	-99 to +99	To adjust the color saturation at high-luminance areas
			OFF	ON, OFF	
		AUTO KNEE	OFF	OFF, AUTO	
		POINT LIMIT	0	-99 to +99	Absolute value is displayed in ABS mode.
		SLOPE	0	-99 to +99	Absolute value is displayed in ABS mode.
ABS			Highlighted: ABS (Absolute) mode		
<WHITE CLIP> Adjusting the level to white-clip the high-luminance areas	P07	W CLIP	[R] [G] [B] [M] 0 0 0 0	-99 to +99	R, G, B, and M (master) values can be independently set. Absolute values are displayed in ABS mode except for M (master).
			OFF	ON, OFF	
		ABS			Highlighted: ABS (Absolute) mode
<DETAIL 1> Adjusting the emphasis of the contours in video	P08	DETAIL	OFF	ON, OFF	Fixed to OFF in Cine mode
		LEVEL	0	-99 to +99	Absolute value is displayed in ABS mode.
		LIMITER	[M] 0	-99 to +99	To adjust the level to clip the maximum value of the emphasis signal Absolute values are displayed in ABS mode except for M (master).
			[WHT] 0	-99 to +99	
			[BLK] 0	-99 to +99	
		CRISP	0	-99 to +99	To adjust the level for noise suppression (Absolute values are displayed in ABS mode)
		LVL DEP	0	-99 to +99	To adjust the emphasis elements suppressed by gamma (Absolute values are displayed in ABS mode.)
			OFF	ON, OFF	
ABS			Highlighted: ABS (Absolute) mode		

PAINT menu					
Page title & purpose	No.	Item	Default	Settings	Remarks
<DETAIL 2> Adjusting the emphasis of the contours in video	P09	H/V RATIO	0	-99 to +99	To specify the vertical factor of the contour emphasis (Absolute values are displayed in ABS mode)
		FREQ	0	-99 to +99	To adjust the video frequency components to be emphasized (Absolute values are displayed in ABS mode.)
		MIX RATIO	0	-99 to +99	Absolute value is displayed in ABS mode.
		KNEE APT	0	-99 to +99	For contour emphasis in high-luminance areas compressed by the KNEE function (Absolute values are displayed in ABS mode.)
			OFF	ON, OFF	
		ABS			Highlighted: ABS (Absolute) mode
<SKIN DETAIL> Emphasizing the contours of the specific color components	P10	SKIN DTL	OFF	ON, OFF	Fixed to OFF in Cine mode
		SKIN GATE	OFF	OFF, 1, 2, 3	1, 2, 3: Skin gate can be set to ON for the specified channel only. With the ON setting, a zebra pattern is displayed for the color component affected by the DETAIL function.
		ABS			Highlighted: ABS (Absolute) mode
			[1] [2] [3] OFF OFF	ON, OFF	The skin tone detail function can be independently set for each channel (channel 1 is always ON).
		HUE	EXEC EXEC EXEC	Execute by ENTER.	HUE: For automatic detection of the target color
		PHASE	0 0 0	0 to 359	Absolute values are indicated for LEVEL only in ABS mode.
		WIDTH	29 29 29	0 to 90	
		SAT	-89 -89 -89	-99 to +99	
		LEVEL	0 0 0	-99 to +99	
<USER MATRIX> Adjusting the color components without affecting the black and white components	P11	R-G	0	-99 to +99	
		R-B	0	-99 to +99	
		G-R	0	-99 to +99	
		G-B	0	-99 to +99	
		B-R	0	-99 to +99	
		B-G	0	-99 to +99	
		MATRIX	OFF	ON, OFF	
		USER	- -	ON, OFF, - -	Invalid when MATRIX is OFF (- - indication)
		MULTI	- -	ON, OFF, - -	Invalid when MATRIX is OFF (- - indication)

PAINT menu					
Page title & purpose	No.	Item	Default	Settings	Remarks
<MULTI MATRIX> Adjusting the color components independently by dividing into 16 axes	P12	PHASE	0	0, 23, 45, 68, 90, 113, 135, 158, 180, 203, 225, 248, 270, 293, 315, 338	Select an axis (angle) at PHASE for which the multimatrix adjustment is to be made, and set HUE and SAT. (HUE and SAT can be adjusted independently for 16 axes.)
				B, B+, MG-, MG, MG+, R, R+, YL-, YL, YL+, G-, G, G+, CY, CY+, B-	
		HUE	0	-99 to +99	
		SAT	0	-99 to +99	
		ALL CLEAR		Execute by ENTER.	
		GATE	OFF	ON, OFF	
		MATRIX	OFF	ON, OFF	
		USER	--	ON, OFF, --	
MULTI	--	ON, OFF, --	Invalid when MATRIX is OFF (-- indication)		
<SHUTTER/FPS> Adjusting the shutter while observing the shutter angles and frequencies	P13 (U20)	SHUTTER	OFF	OFF, STEP, VARIABLE (ECS)	
		STEP	1	1 to 8	The shutter angle and the equivalent frequency values set for the selected step shutter are displayed in the [deg] and [Hz] columns.
		VAR	360.0	360.0 to 4.2	The frequency obtained according to the angle selected in the [deg] column and the FRAME RATE value is displayed in the [Hz] column.
		FRAME RATE	--	For S23.98PsF/S24PsF: 1 to 24 For S25PsF: 1 to 25 For S29.97PsF/S30PsF: 1 to 30 For S50P: 1 to 50 For S59.94P/S60P: 1 to 60	When the video format is fixed, the value is indicated in parentheses.
		COMPENSATION			ANGLE and GAIN cannot be set to ON simultaneously.
		ANGLE	OFF	ON, OFF	
		GAIN	OFF	ON, OFF	

PAINT menu						
Page title & purpose	No.	Item	Default	Settings	Remarks	
<SCENE FILE> Storing and retrieving scene files (data set by the PAINT menu)	P14	1			When storing a file in camera memory, specify the number before executing STORE. When reading, only specify the number.	
		2				
		3				
		4				
		5				
		STORE			Execute by ENTER.	
		STANDARD			Execute by ENTER.	To read the standard paint data
		READ (MS→CAM)			Execute by ENTER.	To load five scene files from a "Memory Stick" to internal memory
		WRITE (CAM→MS)			Execute by ENTER.	To write five scene files in the camera's memory to a "Memory Stick"
		FILE ID			Max.14 characters	Enter a comment for the scene files to be written to a "Memory Stick."
		CAM CODE			Camera code	display only (When files made on are detected, "F23" is displayed.)
DATE			Date of file creation	display only		

4-3-3 MAINTENANCE Menu

	: Valid in Custom mode only
	: Valid in both Cine and Custom modes
Execute by ENTER.	: Execute by pushing on the MENU SEL/ENTER dial.

MAINTENANCE menu					
Page title & purpose	No.	Item	Default	Settings	Remarks
<BASE SETTING> Setting the basic operation mode	M01	SHOOT MODE	CINE	CINE, CUSTOM	
		D-RANGE	EXTEND	EXTEND, NORMAL	EXTEND: To improve the dynamic range and sensitivity Fixed to EXTEND in Cine mode
		COLOR SPACE	WIDE	WIDE, F900	WIDE: Wide color space designed for this camera F900: Color space equivalent to HDC-F950

MAINTENANCE menu					
Page title & purpose	No.	Item	Default	Settings	Remarks
<AUTO SETUP> Various auto balance adjustments	M02	AUTO BLACK		Execute by ENTER.	
		AUTO WHITE		Execute by ENTER.	
		AUTO LEVEL		Execute by ENTER.	
		AUTO WHITE SHADING		Execute by ENTER.	Do not execute if a flat white subject is not available.
		AUTO BLACK SHADING		Execute by ENTER.	
		TEST	OFF	OFF, TEST1, TEST2	
<WHITE SHADING> Adjusting the shading of white level	M03	V SAW	[R] [G] [B] 0 0 0	-99 to +99	R, G, and B values can be independently set. V SAW, H SAW: To vertically or horizontally adjust the slope of shading compensation V PARA, H PARA: To vertically or horizontally adjust the irregularity of shading compensation
		V PARA	0 0 0	-99 to +99	
		H SAW	0 0 0	-99 to +99	
		H PARA	0 0 0	-99 to +99	
		WHITE	0 0 0	-99 to +99	
		AUTO WHITE SHADING		Execute by ENTER.	
		WHITE SHAD MODE	RB	RGB, RB	RGB: To adjust the shading independently for R, G, and B RB: To adjust R and B according to G
		3D WHITE SHAD	ON	ON, OFF	
<BLACK SHADING> Adjusting the shading of black level	M04	V SAW	[R] [G] [B] [M] 0 0 0	-99 to +99	R, G, and B values can be independently set. M (master) value can also be set for BLACK. V SAW, H SAW: To vertically or horizontally adjust the slope of shading compensation V PARA, H PARA: To vertically or horizontally adjust the irregularity of shading compensation
		V PARA	0 0 0	-99 to +99	
		H SAW	0 0 0	-99 to +99	
		H PARA	0 0 0	-99 to +99	
		BLK SET	0 0 0	-99 to +99	
		BLACK	0 0 0 0	-99 to +99	
		MASTER GAIN	0 dB	-3, 0, 3, 6, 9, 12 dB	
		AUTO BLACK SHADING		Execute by ENTER.	
		2D BLACK SHAD	ON	ON, OFF	
<OHB MATRIX> Adjusting the colors at the CCD block (OHB) to match the colors among multiple cameras (can be stored in the OHB file)	M05	PHASE	0	0, 23, 45, 68, 90, 113, 135, 158, 180, 203, 225, 248, 270, 293, 315, 338	To select an axis (angle) at PHASE for which the OHB matrix adjustment is to be made, and set HUE and SAT (HUE and SAT can be adjusted independently for 16 axes).
		HUE	0	-99 to +99	
		SAT	0	-99 to +99	
		ALL CLEAR		Execute by ENTER.	To clear the HUE and SAT values for all PHASE settings
		OHB MATRIX	ON	ON, OFF	Always ON in Cine mode
		MATRIX	OFF	ON, OFF	Always OFF in Cine mode

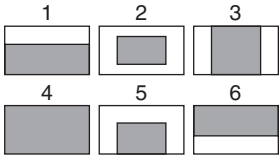
MAINTENANCE menu					
Page title & purpose	No.	Item	Default	Settings	Remarks
<AUTO IRIS> Auto iris adjustment	M06	AUTO IRIS	OFF	ON, OFF	
		WINDOW	1	1, 2, 3, 4, 5, 6	Select the auto iris windows:  The shaded parts indicate the area where light detection occurs.
		OVERRIDE	0	-99 to +99	To set the override to temporarily change the reference value for brightness of the automatic iris level, in the range of ± 2 steps: -99: Two steps to fully closed iris +99: Two steps to fully open iris The setting returns to "0" when the power is turned off.
		IRIS LEVEL	0	-99 to +99	± 4 steps
		APL RATIO	65	-99 to +99	To adjust the response of the iris for high-luminance subjects
		IRIS GAIN	0	-99 to +99	To adjust the iris operation sensitivity
		IRIS CLOSE	OFF	ON, OFF	
<OUTPUT FORMAT> Setting the output video format	M07	CURRENT	23.98PsF 4:4:4		The current format is displayed.
		SCAN	PROGRESSIVE	PROGRESSIVE, INTERLACE	When INTERLACE is selected for SCAN, select half the value of the field frequency in FRAME.
		FRAME	23.98	23.98, 24, 25, 29.97, 30, 50, 59.94, 60	
		SIGNAL	4:4:4 RGB	4:4:4 RGB, 4:2:2 YCbCr	
		SELECT FPS	OFF	ON, OFF	
		SET FORMAT		Execute by ENTER.	
<DOWN CONVERTER> Setting the aspect ratio for VBS output	M08	ASPECT	SQ	SQ, EC	SQ: Squeeze EC: Edge Crop
<POWER SAVE> Selecting the output power save mode	M09	MONITOR OUT	ACTIVE	PWR SAVE, ACTIVE	
		DOWN CONVERTER	ACTIVE	PWR SAVE, ACTIVE	

MAINTENANCE menu					
Page title & purpose	No.	Item	Default	Settings	Remarks
<BATT ALARM SET> Setting the voltage values to trigger alarm indications	M10	DC IN (24 V)			
		TYPE	AC ADP	BATT1, BATT2, AC ADP	BATT1/BATT2: Batteries AC ADP: AC adaptor
		NEAR END	22.2 V	0.1 to 30.0 V	Fixed to the default value for AC ADP
		END	21.6 V	0 to 29.9 V	Fixed to the default value for AC ADP
		DC IN (12 V)			
		TYPE	AC ADP	BATT1, BATT2, AC ADP	BATT1/BATT2: Batteries AC ADP: AC adaptor
		NEAR END	11.1 V	11.0 to 17.0 V	Fixed to the default value for AC ADP
END	10.8 V	10.5 to 14.0 V	Fixed to the default value for AC ADP		
<DATE> Setting the built-in clock	M11	DATE/TIME		yyyy/mm/dd hh : mm	
<OTHERS 1> Setting various subsidiary functions	M12 (U21)	FAN MODE	AUTO1	AUTO1, AUTO2, MIN, MAX	To select the operation modes of the fans AUTO1: Normal AUTO2: MIN mode except in REC
		CAM BARS	OFF	ON, OFF	To turn the built-in color generator on or off
		IMAGE INVERT	OFF	ON, OFF	To turn the image-inversion function on or off (ON to set the camera picture upside-down)

MAINTENANCE menu					
Page title & purpose	No.	Item	Default	Settings	Remarks
<OTHERS 2> Setting various subsidiary functions	M13	DATE TYPE	5 M/D/Y	1 Y/Mn/D 2 Mn/D 3 D/M/Y 4 D/M 5 M/D/Y 6 M/D	To select the date display mode Y: Year Mn: Month (numeric) M: Month (character string) D: Day
		F NO. DISP	CONTROL	CONTROL, RETURN	Select the IRIS position indication: CONTROL: To display the value from the camera RETURN: To display the value returned from the lens
		V DTL CREATION	Y	NAM, G, R+G, Y	To specify from which signal the vertical detail volume is to be created NAM: The highest signal among R, G, and B G: G signal R+G: additional value of the R signal and G signal Y: Y signal
		DTL H/V MODE	H/V	H/V, V ONLY	H/V: To change the H detail at the same time when adjusting the V detail V ONLY: To adjust V detail while maintaining the H detail
		TEST2 MODE	20% STEP	20% STEP, 10STEP	20% STEP: 20%-steps up to full scale when gamma is OFF 10STEP: 10%-steps up to 100% when gamma is OFF
		WHITE SETUP MODE	A.LVL	AWB, A.LVL	A.LVL: To return the white value to "0" when STANDARD is executed AWB: To return the white value to the AWB value when STANDARD is executed

4-3-4 NETWORK Menu

The NETWORK menu items can be set in both Cine and Custom modes.

For details, see “ *Parameter Settings*” (page 89).

Execute by ENTER. Execute by pushing on the MENU SEL/ENTER dial.

NETWORK menu						
Page title	No.	Item	Default	Settings	Remarks	
<IP ADDR SET>	N01	HOST IP ADDRESS	0.0.0.0	0.0.0.0 to 255.255.255.255		
		SUBNET MASK	255.255.255.0	0.0.0.0 to 255.255.255.255		
		DEFAULT GATEWAY	0.0.0.0	0.0.0.0 to 255.255.255.255		
		SET		Execute by ENTER.	Power must be turned off then on again to activate the execution.	
<ETHER I/F CONF>	N02	AUTO NEGOTIATION	ON			
		CONNECT CONFIGURATION				
		CONNECT SPEED	100M	10M, 100M		
		DUPLEX MODE	FULL	HALF, FULL		
		SET		Execute by ENTER.	Power must be turned off then on again to activate the execution.	
<700PTP SETTING>	N03	NS MODE	LEGACY	LEGACY, BRIDGE, MCS		
		MCS MODE	(CLIENT)		fixed	
		CAMERA NO.	0	0 to 24	Select a number other than 0 when connected.	
		MASTER IP ADDRESS	0.0.0.0	0.0.0.0 to 255.255.255.255		
		SET		Execute by ENTER.		
<NETWORK RESET>	N04	ALL RESET		Execute by ENTER.	To initialize all the NETWORK menu settings	

4-3-5 FILE Menu

For details on the files, see “Chapter 5 Storage and Retrieval of User Setting Data”.

: Valid in Custom mode only

: Valid in both Cine and Custom modes

Execute by ENTER. : Execute by pushing on the MENU SEL/ENTER dial.

FILE menu					
Page title	No.	Item	Default	Settings	Remarks
<OPERATOR FILE>	F01	READ (MS→CAM)		Execute by ENTER.	To read the operator file from a “Memory Stick”
		WRITE (CAM→MS)		Execute by ENTER.	To write the current settings of the operator file items to a “Memory Stick”
		PRESET		Execute by ENTER.	To set the operator file items to the preset values in internal memory
		FILE ID		max.14 characters	Enter a comment for the operator file to be written to a “Memory Stick.” See “Specifying a character string” (page 54).
		CAM CODE	F23	Camera code	display only
		DATE			display only
<SCENE FILE>	F02	1			To store and load scene files (paint data): When storing a file in the camera’s memory, specify the number before executing STORE. When reading, only specify the number.
		2			
		3			
		4			
		5			
		STORE		Execute by ENTER.	
		STANDARD		Execute by ENTER.	To read the standard paint data stored in the reference file
		READ (MS→CAM)		Execute by ENTER.	To load five scene files from a “Memory Stick” to the camera’s memory
		WRITE (CAM→MS)		Execute by ENTER.	To write five scene files in the camera’s memory to a “Memory Stick”
		FILE ID		Max.14 characters	Enter a comment for the scene files to be written to a “Memory Stick.” See “Specifying a character string” (page 54).
		CAM CODE	F23	Camera code	display only
		DATE			display only

FILE menu					
Page title	No.	Item	Default	Settings	Remarks
<REFERENCE>	F03	STORE FILE		Execute by ENTER.	To store the current settings of the reference file items in the reference file in the camera's memory.
		STANDARD		Execute by ENTER.	To read the standard values in the reference file in the camera's memory.
		READ (MS→CAM)		Execute by ENTER.	To load a reference file from a "Memory Stick"
		WRITE (CAM→MS)		Execute by ENTER.	To write the current settings of the reference file items as a reference file to a "Memory Stick"
		FILE ID		Max.14 characters	Enter a comment for the reference file to be written to a "Memory Stick." See "Specifying a character string" (page 54).
		CAM CODE	F23	Camera code	display only
		DATE			display only
<USER GAMMA>	F04	READ (MS→CAM)		Execute by ENTER.	To load user gamma tables from a "Memory Stick"
		FILE ID		Max.14 characters	display only
		CAM CODE	F23	Camera code	display only
		DATE			display only
<LENS FILE>	F05	STORE FILE		Execute by ENTER.	
		No.	1	1 to 32	
		NAME	No Offset		
		F NO	F1.7	F1.0 to F3.4	
		CENTER			To set and store the center marker position: H: Increasing the value moves it to the right. V: Increasing the value moves it downwards.
		H	0	-20 to +20	
		V	0	-20 to +20	
		STORE		Execute by ENTER.	
LENS MS READ/ WRITE		Execute by ENTER.	To jump to the subpage		
<LENS FILE> subpage		READ (MS→CAM)		Execute by ENTER.	To load a lens file from a "Memory Stick" (max. 32 files)
		WRITE (CAM→MS)		Execute by ENTER.	To write the current settings of the lens file items as a lens file to a "Memory Stick"
		FILE ID		Max.14 characters	Enter a comment for the lens file to be written to a "Memory Stick." See "Specifying a character string" (page 54).
		CAM CODE	F23	Camera code	display only
		DATE			display only

FILE menu					
Page title	No.	Item	Default	Settings	Remarks
<OHB FILE>	F06	STORE FILE		Execute by ENTER.	To store the offset values of the items specific to the CCD (No repeated store operation is necessary even if the CCD is reattached)
<FILE PRESET>	F07	OPERATOR FILE		Execute by ENTER.	To resume the factory-set status
		USER GAMMA FILE		Execute by ENTER.	To resume the factory-set status
		LENS FILE		Execute by ENTER.	To resume the factory-set status
		REFERENCE FILE		Execute by ENTER.	To resume the factory-set status
		10 SEC CLEAR	OFF	ON, OFF	ON: To return a specific item in the reference file to the factory-set value. <i>For details, see "5-3-8 Resetting to the Initial Settings" (page 85).</i>
		OHB FILE		Execute by ENTER.	To jump to the <OHB FILE> subpage
		USER MENU		Execute by ENTER.	To resume the factory-set status
		M. S. FORMAT		Execute by ENTER.	To initialize a "Memory Stick"
<OHB FILE> (<FILE PRESET> subpage)		OHB WHITE SHADE (ALL)		Execute by ENTER.	To return all the WHITE SHADING data in the OHB file to their factory-set statuses.
		3D WHITE SHADING		Execute by ENTER.	To return only the 3D WHITE SHADING setting to its factory-set status
		BLACK SHADING		Execute by ENTER.	To return only the BLACK SHADING setting to its factory-set status
		ND OFFSET		Execute by ENTER.	To return only the ND OFFSET setting to its factory-set status
		MATRIX		Execute by ENTER.	To return only the MATRIX setting to its factory-set status

4-3-6 DIAGNOSIS Menu

This menu is only for viewing and no setting is made using this menu.

Page title	No.	Item	Indication	Remarks
<BOARD STATUS>	D01	OHB	OK, NG	display only (If NG is displayed, consult your local Sony representative.)
		AD	OK, NG	
		DPR	OK, NG	
		VDA	OK, NG	
		TR	OK, NG	
		AT	OK, NG	
<DOCK STATUS>	D02	TOP	NONE, IF BOX, VTR, OTHERS	display only
		REAR	NONE, IF BOX, VTR, OTHERS	display only
<PLD VERSION>	D03	TG	Vx.xxx	display only
		AD	Vx.xxx	display only
		PRE	Vx.xxx	display only
		POST	Vx.xxx	display only
		TX	Vx.xxx	display only
		RX	Vx.xxx	display only
		VDA	Vx.xxx	display only
		AT	Vx.xxx	display only
<ROM VERSION>	D04 (U21)	MAIN	x.xx	display only
		NET	x.xx	display only

4-4 Editing the USER Menu

You can select desired pages and items from the OPERATION, PAINT, MAINTENANCE, NETWORK, FILE, and DIAGNOSIS menus and register them to the USER menu. If you specify pages or items frequently used for the USER menu, you can easily call and use them.

The USER MENU CUSTOMIZE menu allows you to configure a USER menu that consists only of pages and items that you need, by your adding, deleting or replacing pages.

Creating a new page

The USER MENU CUSTOMIZE menu allows you to add a new page to the USER menu.

While the EDIT page contains factory-preset items, the USER 1 EDIT to USER 19 EDIT pages are all blank in their initial state. You can register up to 10 items, including blank lines, on each of these pages.

To create a new page, proceed as follows.

- 1 While holding the CANCEL/STATUS button pressed, press the VF MENU/DISPLAY button.

The TOP MENU screen appears.

- 2 Turn the MENU SEL/ENTER dial to move the pointer to “USER MENU CUSTOMIZE,” then push on the MENU SEL/ENTER dial.

If this is the first time the USER MENU CUSTOMIZE menu has been displayed, the CONTENTS page of the menu appears.

```

CONTENTS      E00 TOP
↓ ↓
01.EDIT PAGE
02.USER 1 EDIT
→03.USER 2 EDIT
04.USER 3 EDIT
05.USER 4 EDIT
06.USER 5 EDIT
07.USER 6 EDIT
08.USER 7 EDIT
09.USER 8 EDIT
10.USER 9 EDIT
  
```

If the USER MENU CUSTOMIZE menu has been used before, the page last accessed appears.

- 3 If the CONTENTS page is displayed, turn the MENU SEL/ENTER dial to move the pointer to any of USER 1 EDIT to USER 19 EDIT then push on the MENU SEL/ENTER dial to display the page.

If a different page is displayed, turn the MENU SEL/ENTER dial until the desired page appears, then push on the MENU SEL/ENTER dial to select the page.

Example: When you select the USER 2 EDIT page

```

USER 2 EDIT  E03 TOP
→
  
```

- 4 Move the pointer to the item to be added (this operation is unnecessary if no item exists on the page, as shown in the figure for step 3) then push on the MENU SEL/ENTER dial.

The EDIT FUNCTION screen appears.

```

EDIT FUNCTION  ESC
→INSERT
MOVE
DELETE
BLANK
  
```

- 5 Move the pointer to “INSERT” and push on the MENU SEL/ENTER dial.

The page with the last item added appears.

```

<SW STATUS>      P22 ESC
FLARE      : → ON
GAMMA      :  ON
BLK GAM    :  OFF
KNEE       :  ON
WHT CLIP   :  ON
DETAIL     :  ON
LVL DEP    :  ON
SKIN DTL   :  OFF
MATRIX     :  OFF
5600K      :  OFF
  
```

- 6 Add the items.
 - ① Turn the MENU SEL/ENTER dial until the page that has the desired items appears, then push on the MENU SEL/ENTER dial.
 - ② Turn the MENU SEL/ENTER dial to move the pointer to the desired item, then push on the MENU SEL/ENTER dial.

The USER 2 EDIT page appears again, displaying the newly added item.

7 Add the remaining items by repeating steps 4 to 6.

You can add up to 10 items on one page.

To delete items from a page

Proceed as follows:

- 1 Move the pointer to the item to be deleted, and push on the MENU SEL/ENTER dial.

The EDIT FUNCTION screen appears.

- 2 Select “DELETE,” and push on the MENU SEL/ENTER dial.

The previously displayed page appears again, and the message “DELETE OK? Yes →No” appears at the upper right.

- 3 To delete, turn the MENU SEL/ENTER dial to move the pointer to “YES,” and push on the MENU SEL/ENTER dial.

To change the order of items on a page

Proceed as follows:

- 1 Turn the MENU SEL/ENTER dial to move the pointer to the item to be moved, then push on the MENU SEL/ENTER dial.

The EDIT FUNCTION screen appears.

- 2 Select MOVE, then push on the MENU SEL/ENTER dial.

The previously displayed page appears again.

- 3 Turn the MENU SEL/ENTER dial to move the pointer to the position where you wish to move the item, then push on the MENU SEL/ENTER dial.

	ITEM MOVE	ESC
↓ ↓		
→UF	OUT : COLOR	
	UF DETAIL : OFF	
	MARKER : ON	
	CURSOR : OFF	
	ZEBRA SW : OFF	
		1
•AS1	: OFF	

The item selected in step 1 moves to the position that you selected in step 3. In the above example, “AS1” is moved to the top and the other items are moved down one line.

To insert a blank line

Proceed as follows:

- 1 Turn the MENU SEL/ENTER dial to move the pointer to the item above which you wish to insert a blank line.

The EDIT FUNCTION screen appears.

- 2 Select “BLANK” then push on the MENU SEL/ENTER dial.

The previously displayed page appears again, and a blank line is inserted above the specified item.

Note

You cannot insert a blank line on a page where 10 items have already been registered.

Adding/deleting/replacing pages

You can add a new page to the USER menu, delete a page from the USER menu or replace pages, using the EDIT PAGE of the USER MENU CUSTOMIZE menu.

To add a page

Proceed as follows:

- 1 Select “USER MENU CUSTOMIZE” on the TOP MENU screen.

If this is the first time the USER MENU CUSTOMIZE menu has been displayed, the CONTENTS page of the menu appears. If the menu has been used before, the last accessed page appears.

- 2 If the CONTENTS page is displayed, turn the MENU SEL/ENTER dial to move the pointer to “EDIT PAGE”, then push on the MENU SEL/ENTER dial to display the EDIT PAGE screen.

If a different page is displayed, turn the MENU SEL/ENTER dial until the EDIT PAGE screen appears, then push on the MENU SEL/ENTER dial to select the page.

	EDIT PAGE	E01	ESC
↓ ↓			
→01.	<UF DISPLAY>		
	02.<' ' IND>		
	03.<MARKER DISPLAY>		
	04.<MARKER SETTING>		
	05.<UF DETAIL>		
	06.<ZEBRA>		
	07.<CURSOR>		
	08.<MONITOR OUTPUT>		
	09.<PB MONI GAMMA>		
	10.<PB MIX SETTING>		

- 3 Turn the MENU SEL/ENTER dial to move the pointer to where you wish to add the page, then push on the MENU SEL/ENTER dial.

The EDIT FUNCTION screen appears.

```

EDIT FUNCTION      ESC
→INSERT
MOVE
DELETE

```

- 4 Select INSERT then push on the MENU SEL/ENTER dial.

The selection screen appears.

```

CONTENTS          ESC
↓ ↓
→01 . USER 1
02 . USER 2
03 . USER 3
04 . USER 4
05 . USER 5
06 . USER 6
07 . USER 7
08 . USER 8
09 . USER 9
10 . USER 10

```

- 5 Turn the MENU SEL/ENTER dial to move the pointer to the desired page, then push on the MENU SEL/ENTER dial.

This adds the number and name of the selected page above the item selected in step 3.

To cancel addition of a page

Before pushing the MENU SEL/ENTER dial in step 5, turn the MENU SEL/ENTER dial to move the pointer to “ESC” at the top right of the screen, then push on the MENU SEL/ENTER dial.

The EDIT PAGE screen appears again.

To delete a page

Proceed as follows:

- 1 On the EDIT PAGE screen of the USER MENU CUSTOMIZE menu, move the pointer to the page to be deleted, and push on the MENU SEL/ENTER dial.

The EDIT FUNCTION screen appears.

- 2 Select “DELETE” then push on the MENU SEL/ENTER dial.

The previously displayed page appears again, and the message “DELETE OK?” appears at the upper right.

```

ITEM DELETE      ESC
DELETE OK? →YES NO
01.<VF DISPLAY>
02.<'! IND>
03.<MARKER DISPLAY>
•04.<MARKER SETTING>
05.<VF DETAIL>
06.<ZEBRA>
07.<CURSOR>
08.<MONITOR OUTPUT>
09.<PB MONI GAMMA>
10.<PB MIX SETTING>

```

- 3 To delete, turn the MENU SEL/ENTER dial to move the pointer to “YES,” then push on the MENU SEL/ENTER dial.

To move a page

Proceed as follows:

- 1 Display the EDIT PAGE screen of the USER MENU CUSTOMIZE menu. Turn the MENU SEL/ENTER dial to move the pointer to the page that you wish to move.

The EDIT FUNCTION screen appears.

- 2 Select “MOVE” then push on the MENU SEL/ENTER dial.

The EDIT PAGE screen appears again.

- 3 Turn MENU SEL/ENTER dial to move the pointer to the position to which you wish to move the page selected in step 1.

```

ITEM MOVE        ESC
↓ ↓
01.<VF DISPLAY>
02.<'! IND>
03.<MARKER DISPLAY>
→04.<MARKER SETTING>
05.<VF DETAIL>
06.<ZEBRA>
07.<CURSOR>
08.<MONITOR OUTPUT>
09.<PB MONI GAMMA>
•10.<PB MIX SETTING>

```

- 4 Push on the MENU SEL/ENTER dial.

The page selected in step 1 is moved to the position selected in step 3.

In the above example, <PB MIX SETTING> moves to the “04” position, and the <MARKER SETTING> and following pages move down one line.

Returning the USER menu to the factory-set status

Use the <FILE PRESET> page of the FILE menu.

For details, see “5-3-8 Resetting to the Initial Settings” (page 85).

5-1 File Configuration

This system permits various settings and adjustment data to be stored as data files in built-in memory or a “Memory Stick” in order to facilitate later operations or adjustments. A stored data file can be retrieved, as required, to reproduce the stored setting statuses.

Note

In Cine mode, some file operations will be limited.

The following six kinds of files are designed for the system:

Operator file

This file stores operational settings not related to picture quality. At shipment, the operator file with the default settings has been stored in built-in memory.

After the default settings are changed, those changed setting data can be stored as the operator file in a “Memory Stick” for later use.

For file operation, use the <OPERATOR FILE> page of the USER (OPERATION) menu or that of the FILE menu.

Items stored

The setting items in the OPERATION menu (*page 55*) and the customized USER menu (*page 75*) can be stored.

Lens files

Names of 32 different lenses, their minimum f-stops, and standard values for these lenses can be registered as lens files in built-in memory of the camera. Files for lenses equipped with the lens extender can contain two sets of data for extender ON or OFF.

When you remount the lens after using another lens, the appropriate compensation for the lens can be achieved easily by reading the file corresponding to the lens.

For file retrieval, use the subdisplay or the <LENS FILE> page of the USER (OPERATION) menu.

Creation and modification of lens files are made in Custom mode.

Adjust necessary items, using the PAINT and MAINTENANCE menus or using the MSU-900/950 Master Setup Unit, then store the adjustment data, using the <LENS FILE> page of the FILE menu or using the MSU-900/950.

You can back up the lens files in a “Memory Stick.”

Note

In Cine mode, only retrieval of lens files is possible. Modification of file data or file creation is not possible.

Items stored

The items that are stored in lens files are marked with “O” in the “L” column of the table in “5-2 List of Items Stored in Files”.

Scene files

A scene file stores data adjusted on the PAINT menu for a specific scene. Up to five sets can be stored as the scene files.

For example, if you store data prepared in rehearsal for a particular scene in a scene file, the data can be retrieved to reproduce the same camera settings for the actual take.

For file operation, use the <SCENE FILE> page of the PAINT or FILE menu. You can also use the MSU-900/950 Master Setup Unit for the file operation.

Scene files are stored in built-in memory. You can also back up the scene files in a “Memory Stick.”

Note

In Cine mode, scene file operation is disabled.

Items stored

The items that are stored in scene files are marked with “O” in the “S” column of the table in “5-2 List of Items Stored in Files”.

Reference file

This file stores the standard settings of the camera that can be used as a reference when adjusting the camera.

If STANDARD is executed on the <SCENE FILE> page of the PAINT menu or the <REFERENCE> page of the FILE menu, or with the MSU-900/950 Master Setup Unit,

manually adjusted values of the camera will be reset to the reference values that have been stored in the reference file. At shipment, the reference file with the initial settings is stored in built-in memory.

The initial settings can be modified, as required, then stored as the new reference file.

For file operation, use the <REFERENCE> page of the FILE menu. You can also use the MSU-900/950 Master Setup Unit for file operation.

You can back up the reference file in a “Memory Stick.”

Notes

- In Cine mode, the reference file data are fixed as those at shipment and cannot be modified.
- As relative adjustment values with regard to the reference file data are stored in a scene file, if data of the reference file are modified, the scene files also need modification.

Items stored

The items that are stored in the reference file are marked with “○” in the “R” column of the table in “5-2 List of Items Stored in Files”.

User-Gamma file

The gamma-curve data (User Gamma) created using CvpFileEditor application software can be loaded to the camera via a “Memory Stick.” This enables reproduction of images closer to those that individual users wish to reproduce.

For file operation, use the <USER GAMMA> page of the FILE menu.

The User-Gamma file is stored in built-in memory. Backup of the User-Gamma file in a “Memory Stick” is not possible.

Note

In Cine mode, operation of the User-Gamma file via a “Memory Stick” is not possible.

OHB file

The OHB file stores the offset values of items specific to the CCD unit.

For file operation, use the <OHB FILE> page of the FILE menu. You can also use the MSU-900/950 Master Setup Unit for this operation.

Note

In Cine mode, the OHB file can be retrieved automatically, but the data in the OHB file cannot be modified.

Items stored

The items that are stored in the OHB file are marked with “○” in the “O” column of the table in “5-2 List of Items Stored in Files”.

5-2 List of Items Stored in Files

The items that are stored in scene files, the reference file, the lens files, and the OHB file are listed in the table below.

For details on setting values, see the corresponding items in the table in “4-3 Menu List” (page 55).

S: Scene file
R: Reference file
L: Lens file
O: OHB file

Menu page (No.)	Item	S	R	L	O
<VIDEO LEVEL> (P02)	WHITE [R] [G] [B]	○	○		
	WHITE [R] [B]	○	○	○	
	BLACK [R] [G] [B] [M]	○	○		
	FLARE [R] [G] [B]	○	○	○	
	V MOD [R] [G] [B] [M]			○	
	FLARE ON/OFF	○	○		
	V MOD ON/OFF		○		
<GAMMA> (P03)	LEVEL [R] [G] [B] [M]	○	○		
	COARSE	○	○		
	TABLE	○	○		
	GAMMA ON/OFF	○	○		
<BLACK GAMMA> (P04)	LEVEL [R] [G] [B] [M]	○	○		
	RANGE	○	○		
	RANGE ON/OFF	○	○		
	BLACK GAMMA ON/OFF	○	○		
<SATURATION> (P05)	SATURATION	○	○		
	SATURATION ON/OFF	○	○		
	LOW KEY SAT	○	○		
	RANGE	○	○		
<KNEE> (P06)	K POINT [R] [G] [B] [M]	○	○		
	K SLOPE [R] [G] [B] [M]	○	○		
	KNEE ON/OFF	○	○		
	KNEE SAT	○	○		
	KNEE SAT ON/OFF	○	○		
	AUTO KNEE	○	○		
	POINT LIMIT	○	○		
	SLOPE	○	○		
<WHITE CLIP> (P07)	W CLIP [R] [G] [B] [M]	○	○		
	W CLIP ON/OFF	○	○		

Menu page (No.)	Item	S	R	L	O
<DETAIL 1> (P08)	DETAIL ON/OFF	○	○		
	LEVEL	○	○		
	LIMITER M	○	○		
	LIMITER WHT	○	○		
	LIMITER BLK	○	○		
	CRISP	○	○		
	LVL DEP	○	○		
	LVL DEP ON/OFF	○	○		
<DETAIL 2> (P09)	H/V RATIO	○	○		
	FREQ	○	○		
	MIX RATIO	○	○		
	KNEE APT	○	○		
	KNEE APT ON/OFF	○	○		
<SKIN DETAIL> (P10)	SKIN DTL ON/OFF	○	○		
	PHASE	○	○		
	WIDTH	○	○		
	SAT	○	○		
	LEVEL	○	○		
<USER MATRIX> (P11)	R-G	○	○		
	R-B	○	○		
	G-R	○	○		
	G-B	○	○		
	B-R	○	○		
	B-G	○	○		
	MATRIX ON/OFF	○	○		
	USER MATRIX ON/OFF	○	○		
	MULTI MATRIX ON/OFF	○	○		
<MULTI MATRIX> (P12)	HUE	○	○		
	SAT	○	○		
<SHUTTER/FPS> (P13)	SHUTTER	○	○		
	VAR	○	○		
<WHITE SHADING> (M03)	V SAW [R] [G] [B]			○	○
	V PARA [R] [G] [B]			○	○
	H SAW [R] [G] [B]			○	○
	H PARA [R] [G] [B]			○	○
	3D WHITE SHAD ON/OFF				○

Menu page (No.)	Item	S	R	L	O
<BLACK SHADING> (M04)	V SAW [R] [G] [B]				○
	V PARA [R] [G] [B]				○
	H SAW [R] [G] [B]				○
	H PARA [R] [G] [B]				○
	BLK SET [R] [G] [B]				○
	MASTER GAIN	○	○		
	<OHB MATRIX> (M05)	HUE			
SAT					○
OHB MATRIX					○
<AUTO IRIS> (M06)	AUTO IRIS	○	○		
	WINDOW	○	○		
	IRIS LEVEL	○	○		
	APL RATIO	○	○		
	IRIS GAIN	○	○	○	
ND filter selection	○				
CC filter selection	○				
ND offset				○	

5-3 File Operations

5-3-1 Using a “Memory Stick”

You can use “Memory Stick PRO” media with this camera. “Memory Stick PRO Duo” can also be used without using a Memory Stick Duo adaptor.

The camera operations have been checked using “Memory Stick PRO” media up to 8GB.

Operations checked with:

MSH-128
MSX-512S
MSX-M2GS
MSX-M4GS
MSX-M8GS

For details on “Memory Stick” media, see “About a “Memory Stick”” (page 93).

Inserting a “Memory Stick”

Insert a “Memory Stick” with the label side up into the “Memory Stick” slot until it clicks and the access lamp lights in red. When the “Memory Stick” is properly set, the lamp illumination changes to green.

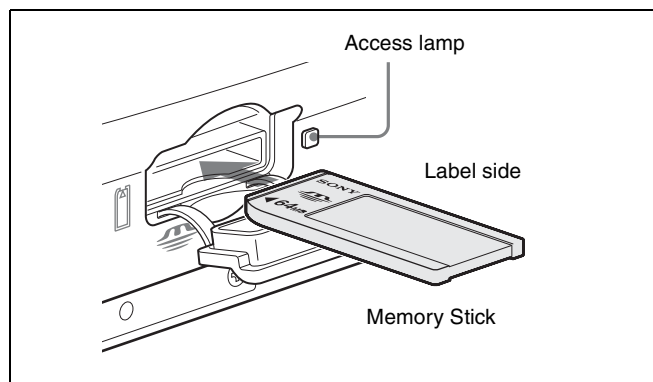

If it does not fit into the slot properly or if there is some resistance when you insert it, the “Memory Stick” may be turned around or upside-down. Do not force the “Memory Stick” into the slot. Confirm the direction of the notch and arrow on the “Memory Stick” before inserting the “Memory Stick,” and then try inserting it again.

Removing the “Memory Stick”

Confirm that the access lamp is not lit in red, then lightly push in the “Memory Stick” to release the lock.

Note

If the access lamp is lit in red, data are being read from or written to the “Memory Stick” At this time, do not shake

the product or subject it to shock. Do not turn off the power to the product or remove the “Memory Stick.” This may damage the data.

Protecting saved data

To prevent accidental erasure of important setup data, use the LOCK switch on the “Memory Stick.”

Slide the switch right to the write protect position. This ensures that you cannot inadvertently overwrite data on the “Memory Stick.”

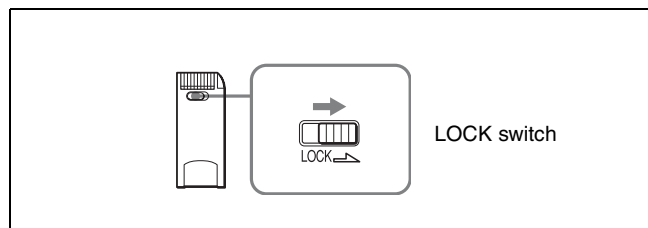

Notes on using and storing the “Memory Stick”

- Avoid touching the connector of the “Memory Stick” or contacting it with a metal object.
- When attaching a label to the “Memory Stick,” use only the label supplied for the “Memory Stick.”
- Do not drop, bend, or submit the “Memory Stick” to external shock.
- Do not disassemble or modify the “Memory Stick.”
- Avoid getting liquids on the “Memory Stick.”
- Avoid using or storing the “Memory Stick” in a location subject to:
 - extremely high temperature such as the hot inside of a car or the outdoors exposed to a burning sun, or a place near a heater
 - direct sunlight
- When storing and carrying the “Memory Stick,” keep it in its original case to ensure protection of important data.
- Do not format the “Memory Stick” using a PC. Formatting of the “Memory Stick” can be performed on the <FILE PRESET> page of the FILE menu.

To format a “Memory Stick”

Use the <FILE PRESET> page of the FILE menu.

- 1 Insert a “Memory Stick” you wish to format into the “Memory Stick” slot of the camera.
- 2 Call up the <FILE PRESET> page of the FILE menu.
- 3 Position the pointer to M.S. FORMAT and push on the MENU SEL/ENTER dial.

```

<FILE PRESET>      F07 TOP
OPERATOR FILE
USER GAMMA FILE
LENS FILE
REFERENCE FILE
10 SEC CLEAR: OFF
OHB FILE
USER MENU
→M.S. FORMAT
FILE PRESET (-OHB)

```

During formatting, “MEMORY STICK ACCESS” is displayed.
When formatting is completed, “COMPLETE” is displayed.

5-3-2 Storage and Retrieval of the Operator File

Use the <OPERATOR FILE> page of the FILE menu.

```

<OPERATOR FILE>  F01 TOP
READ (MS →CAM)
WRITE (CAM→MS )
PRESET

FILE ID:
CAM CODE
DATE

```

The <OPERATOR FILE> page is also included in the USER (OPERATION) menu (see page 46).

To store the operator file in a “Memory Stick”

Perform necessary settings for the operation items and the customized USER menu for the operator file you wish to store.

- 1 Insert a “Memory Stick” into the “Memory Stick” slot of the camera.
- 2 Position the pointer to WRITE (CAM → MS) and push on the MENU SEL/ENTER dial.

You can add a comment (maximum: 14 characters) to the operator file to be stored in the “Memory Stick” by specifying it on the FILE ID line.

For details on how to enter a comment, see “Specifying a character string” (page 54).

To retrieve the operator file stored in a “Memory Stick”

The operator file stored in the “Memory Stick” can be read out into built-in memory of the camera.

- 1 Insert the “Memory Stick” into the “Memory Stick” slot of the camera.
- 2 Position the pointer to READ (MS → CAM) and push on the MENU SEL/ENTER dial.

The camera will be set according to the data loaded from the operator file.

To return the operator file items to the factory-set values

Position the pointer to PRESET and push on the MENU SEL/ENTER dial.

You can also use the <FILE PRESET> page (page 85) of the FILE menu for this purpose.

5-3-3 Registration and Retrieval of the Lens Files

The registered lens files can be retrieved via the subdisplay or the <LENS FILE> page of the OPERATION menu. To register the data you adjusted for the mounted lens as a lens file, or to use a “Memory Stick,” the <LENS FILE> page of the FILE menu is used.

```

<LENS FILE>      F05 TOP
→STORE FILE
No. : 1
NAME: NO Offset
F NO: F1.7
CENTER H: 0
        V: 0   STORE
LENS MS READ/WRITE

```

To store the data as a lens file in built-in memory

Perform necessary settings for the items marked with “○” in the L column of the table in “5-2 List of Items Stored in Files” for the lens file you wish to store.

- 1 Select the file number, and set the file name and the minimum f-stop.

For setting of file names, see “Specifying a character string” (page 54).

- 2 Position the pointer to STORE FILE and push on the MENU SEL/ENTER dial.

Storage of the position settings for the center marker can be independently performed.

To store in or retrieve from a “Memory Stick”

Position the pointer to LENS MS READ/WRITE and push on the MENU SEL/ENTER dial. The subpage will be displayed.

```
<LENS FILE>          ESC
                        READ  (MS →CAM)
                        WRITE (CAM→MS )
FILE ID:
CAM CODE
DATE
```

To store

Position the pointer to WRITE (CAM → MS) then push on the MENU SEL/ENTER dial.

You can add a comment (maximum: 14 characters) to the lens file to be stored in the “Memory Stick” by specifying it on the FILE ID line.

For details on how to enter a comment, see “Specifying a character string” (page 54).

To retrieve

Position the pointer to READ (MS → CAM) then push on the MENU SEL/ENTER dial.

5-3-4 Storage and Retrieval of the Scene Files

Use the <SCENE FILE> page of the FILE menu. The <SCENE FILE> page is also included in the PAINT menu. The operation method is the same.

```
<SCENE FILE>          F02 TOP
  1  2  3  4  5  STORE
  _  _  _  _  _
STANDARD
READ  (MS →CAM)
WRITE (CAM→MS )
FILE ID:
CAM CODE
DATE
```

To store a scene file in built-in memory

Perform necessary settings for the items for the scene file you wish to store.

- 1 Position the pointer to STORE and push on the MENU SEL/ENTER dial.

- 2 Position the pointer to the number of the file in which you wish to store your settings and push on the MENU SEL/ENTER dial.

During the storage process, “MEMORY STICK ACCESS” is displayed.

When storage is completed, “COMPLETE” is displayed.

To retrieve a scene file stored in built-in memory

Position the pointer to the number of the file that you wish to retrieve and push on the MENU SEL/ENTER dial.

The statuses specified in the retrieved file will be reproduced.

To store the scene files in a “Memory Stick”

Five scene files stored in built-in memory of the camera can be read out to a “Memory Stick.”

- 1 Insert a “Memory Stick” into the “Memory Stick” slot of the camera.
- 2 Position the pointer to WRITE (CAM → MS) and push on the MENU SEL/ENTER dial.

You can add a comment (maximum: 14 characters) to the scene files to be stored in the “Memory Stick” by specifying it on the FILE ID line.

For details on how to enter a comment, see “Specifying a character string” (page 54).

To retrieve scene files stored in a “Memory Stick”

Five scene files stored in the “Memory Stick” can be read out into built-in memory of the camera.

- 1 Insert the “Memory Stick” into the “Memory Stick” slot of the camera.
- 2 Position the pointer to READ (MS → CAM) and push on the MENU SEL/ENTER dial.

5-3-5 Storage and Retrieval of the Reference File

Use the <REFERENCE> page of the FILE menu.

```
<REFERENCE>          F03 TOP
STORE FILE
STANDARD

READ  (MS →CAM)
WRITE (CAM→MS )

FILE ID:
CAM CODE
DATE
```

To retrieve the reference file (standard settings) stored in built-in memory

Position the pointer to STANDARD and push on the MENU SEL/ENTER dial.

To store the reference file in built-in memory

Perform necessary settings for the reference-file items you wish to store.

Position the pointer to STORE FILE and push on the MENU SEL/ENTER dial.

To store the reference file in a “Memory Stick”

- 1 Insert a “Memory Stick” into the “Memory Stick” slot of the camera.
- 2 Position the pointer to WRITE (CAM → MS) and push on the MENU SEL/ENTER dial.

You can add a comment (maximum: 14 characters) to the reference file to be stored in the “Memory Stick” by specifying it on the FILE ID line.

For details on how to enter a comment, see “Specifying a character string” (page 54).

To retrieve the reference file stored in the “Memory Stick”

The reference file stored in the “Memory Stick” can be read out into built-in memory of the camera.

- 1 Insert the “Memory Stick” into the “Memory Stick” slot of the camera.
- 2 Position the pointer to READ (MS → CAM) and push on the MENU SEL/ENTER dial.

The camera will be adjusted according to the data of the reference file.

5-3-6 Reading of the User Gamma

To read out gamma-curve (User Gamma) data that have been created using CvpFileEditor application software from the “Memory Stick,” use the <USER GAMMA> page of the FILE menu.

```
<USER GAMMA>        F04 TOP
→READ (MS →CAM)

FILE ID
CAM CODE
DATE
```

Insert the “Memory Stick” into the “Memory Stick” slot of the camera. Position the pointer to READ (MS → CAM) and push on the MENU SEL/ENTER dial.

For details on how to use the User Gamma, see “3-11-3 Using the User Gamma” (page 47).

5-3-7 Storage of the OHB File

Use the <OHB FILE> page of the FILE menu.

- 1 Execute STANDARD on the <REFERENCE> page of the FILE menu.
- 2 Using the MAINTENANCE menu, perform necessary settings for the items marked with “O” in the “O” column of the table in “5-2 List of Items Stored in Files” for the file you wish to store.
- 3 Call up the <OHB FILE> page of the FILE menu, position the pointer to STORE FILE then push on the MENU SEL/ENTER dial.

```
<OHB FILE>          F06 TOP
→STORE FILE
```

Adjusting the ND offset values

White balance may be slightly shifted in each ND filter setting. In such a case, adjust the offset values.

The ND offset adjustment stores white balance compensation values for each filter, using the white balance with the ND:1 and CC: A settings as a reference. To adjust the ND offset values, proceed as follows:

- 1 Switch the camera to Custom mode, referring to “3-1-2 Switching of the Basic Operation Modes” (page 26).
- 2 Execute STANDARD on the <REFERENCE> page of the FILE menu.
- 3 Execute AUTO BLACK on the <AUTO SETUP> page of the MAINTENANCE menu.
- 4 Connect a waveform monitor to the MONITOR OUT HD SDI connector 1 or 2 of the camera.
- 5 Select ND: 4 and CC: E (see page 30) and shoot a gray-scale chart.

Check that the lighting is in a condition that permits a video level in the range of 560 to 630 mV to be obtained, and write down the current video level.

Note

If a video level in the range of 560 to 630 mV cannot be obtained, do not adjust the ND offsets.

- 6 Select ND: 1 and CC: A.
- 7 Adjust the iris of the lens so that the video level you wrote down in step 5 is obtained.
- 8 Perform the auto white balance adjustment.
- 9 Change to ND: 2 and repeat steps 7 and 8.
- 10 Change to ND: 3 and repeat steps 7 and 8.
- 11 Change to ND: 4 and repeat steps 7 and 8.
- 12 Change to ND: 1 and CC: E, then repeat steps 7 and 8.
- 13 Repeat steps 9 to 11.
- 14 Store the ND offset values in the OHB file, by executing STORE FILE on the <OHB FILE> page of the FILE menu.

Note

Be sure to accurately adjust to the video level you noted in step 5. If the level is not obtained through the iris adjustment of the lens, use the shutter function or the master gain adjustment.

To use the ND offset values

An appropriate offset value is automatically retrieved when you change the ND filter setting.

To initialize the ND offset values

Perform ND OFFSET on the <OHB FILE> page (subpage of the <FILE PRESET> page of the FILE menu) (see page 85).

5-3-8 Resetting to the Initial Settings

With the <FILE PRESET> page of the FILE menu, data in the modified files or the configuration of the edited USER menu can be reset to the initial settings, by type of files or collectively.

```

<FILE PRESET>      F07 TOP
->OPERATOR FILE
  USER GAMMA FILE
  LENS FILE
  REFERENCE FILE
  10 SEC CLEAR: OFF
  OHB FILE
  USER MENU
  M.S. FORMAT

FILE PRESET (-OHB)
  
```

To reset data of files by type of files

To reset data of the operator file, User-Gamma file, lens files, and reference file

Position the pointer to the corresponding line then push on the MENU SEL/ENTER dial.

The data in the corresponding file(s) in built-in memory will be reset to the initial settings.

The configuration of the USER menu can be reset in the same manner.

To reset the data of the OHB file

In a case of the OHB file, resetting can be performed by item.

Position the pointer to OHB FILE then push on the MENU SEL/ENTER dial. The <OHB FILE PRESET> page will be displayed.

```

<OHB FILE PRESET>  ESC
->WHITE SHADING(ALL)
  3D WHITE SHADING
  BLACK SHADING
  NO OFFSET
  MATRIX
  
```

Position the pointer to the item you wish to reset then push on the MENU SEL/ENTER dial.

To reset a specific item in the reference file to the initial setting

The items in the reference file can be reset individually.

- 1 On the <FILE PRESET> page, set 10 SEC CLEAR to ON.
- 2 Shift to the menu page on which the item you wish to reset is located. Position the pointer to the item you wish to reset then hold the MENU SEL/ENTER dial pressed.

Continue to hold the MENU SEL/ENTER dial pressed after the pointer changes to a question mark (?).

After about 3 seconds, the current setting of the corresponding item will be reset to the initial setting, and “CLEARED” will be displayed.

If the dial is continuously held pressed, after about additional 7 seconds, the setting of the corresponding item that is stored in the reference file will be reset to the initial setting, and “REF CLEARED” will be displayed.

To reset the files and settings collectively

All files except the OHB file can be reset simultaneously. Position the pointer to FILE PRESET (–OHB) on the <FILE PRESET> page then push on the MENU SEL/ENTER dial. The message “POWER OFF TO SET” will be displayed. Set the POWER switch of the camera to OFF.

Appendixes

Using the RM-B750

When the RM-B750 Remote Control Unit (optional) is connected, you can control the menu settings of this camera and monitor the camera images on the display of the RM-B750.

Connection

Using the remote control cable supplied with the RM-B750, connect the CAMERA connector of the RM-B750 and the REMOTE connector of the camera.

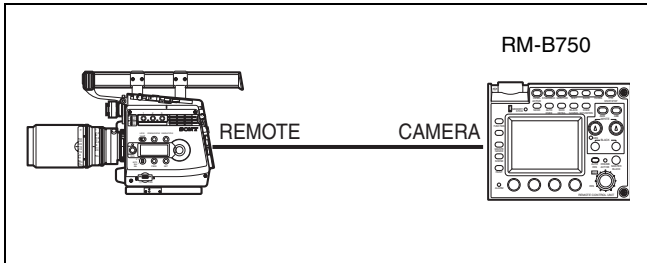

Operating the Menu of This Camera

The menu of this camera can be displayed on the display of the RM-B750 and be set from the RM-B750.

Settings on this camera

- Set RM VIDEO to VBS on the <MONITOR OUTPUT> page of the USER (OPERATION) menu.
- Set VBS of CHAR to ON on the <CHAR/MARK MIX> page of the USER (OPERATION) menu.
- Set NS MODE to LEGACY on the <700PTP SETTING> page of the NETWORK menu.

Settings on the RM-B750

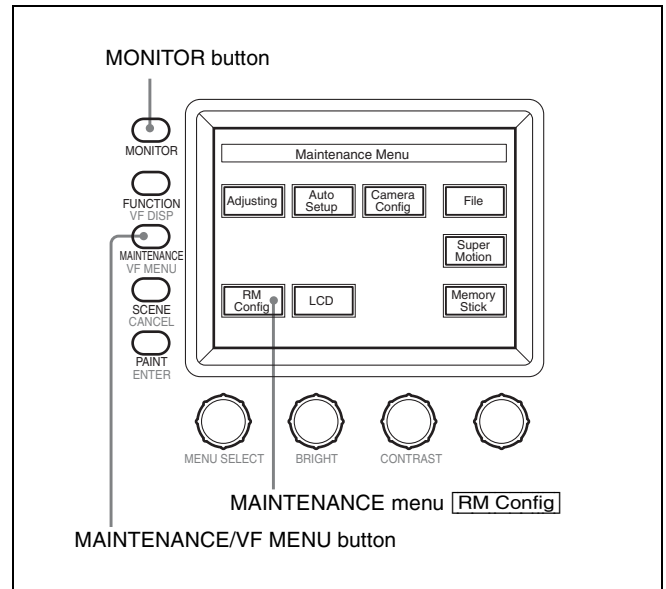

- 1 Press the MAINTENANCE/VF MENU button to display the maintenance menu on the LCD/touch panel.
- 2 Press **RM Config** on the touch panel to display the RM configuration menu.
- 3 Press **Security** to set the unit to Engineering Mode.
- 4 Press **SW Setting** to change to the SW Setting display and set the VF Menu to Control Enable.
- 5 Press **Exit** to cancel the menu mode.

If you press the MONITOR button, a menu page of this camera will be displayed on the display of the RM-B750. Pressing the MAINTENANCE/VF MENU button enables the menus of this camera to be set from the RM-B750.

For details on the operations, refer to the Operation Manual of the RM-B750.

Monitoring the Camera Image

Settings on this camera

Set RM VIDEO to VBS on the <MONITOR OUTPUT> page of the USER (OPERATION) menu.

Settings on the RM-B750

Press the MONITOR button. The camera image will be displayed on the display of the RM-B750.

VBS signals are fed to an external monitor if connected via the MONITOR connector of the RM-B750.

Using the MSU-900/950

You can adjust this camera from the MSU-900/950 Master Setup Unit via an Ethernet cable.

You can use either Bridge mode to control a camera from an exclusive MSU-900/950 or Multi mode to control multiple cameras from one MSU-900/950 or from multiple remote controllers, including the MSU-900/950 via a HUB.

Connections

Bridge mode

For using one camera on an Ethernet network.

Using an Ethernet cable, connect the MSU-900/950 to the  (network) connector of this camera.

You may use the remote cable connection simultaneously.

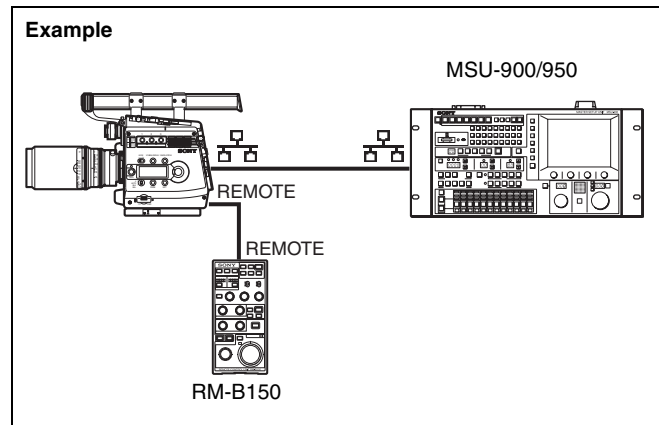

Multi (MCS) mode

Connect the Ethernet cable connected to the  (network) connector of this camera to the HUB.

You may use the remote cable connections simultaneously.

Notes

- Remote cable connections will be invalid if the master unit is not connected to the same network.
- If the master-specified MSU-900/950 is off, all the network/remote communications are disabled.
- Do not connect devices having the same IP address to the network.
- Do not connect cameras having the same ID number to the network. Communications would be disabled on both cameras.

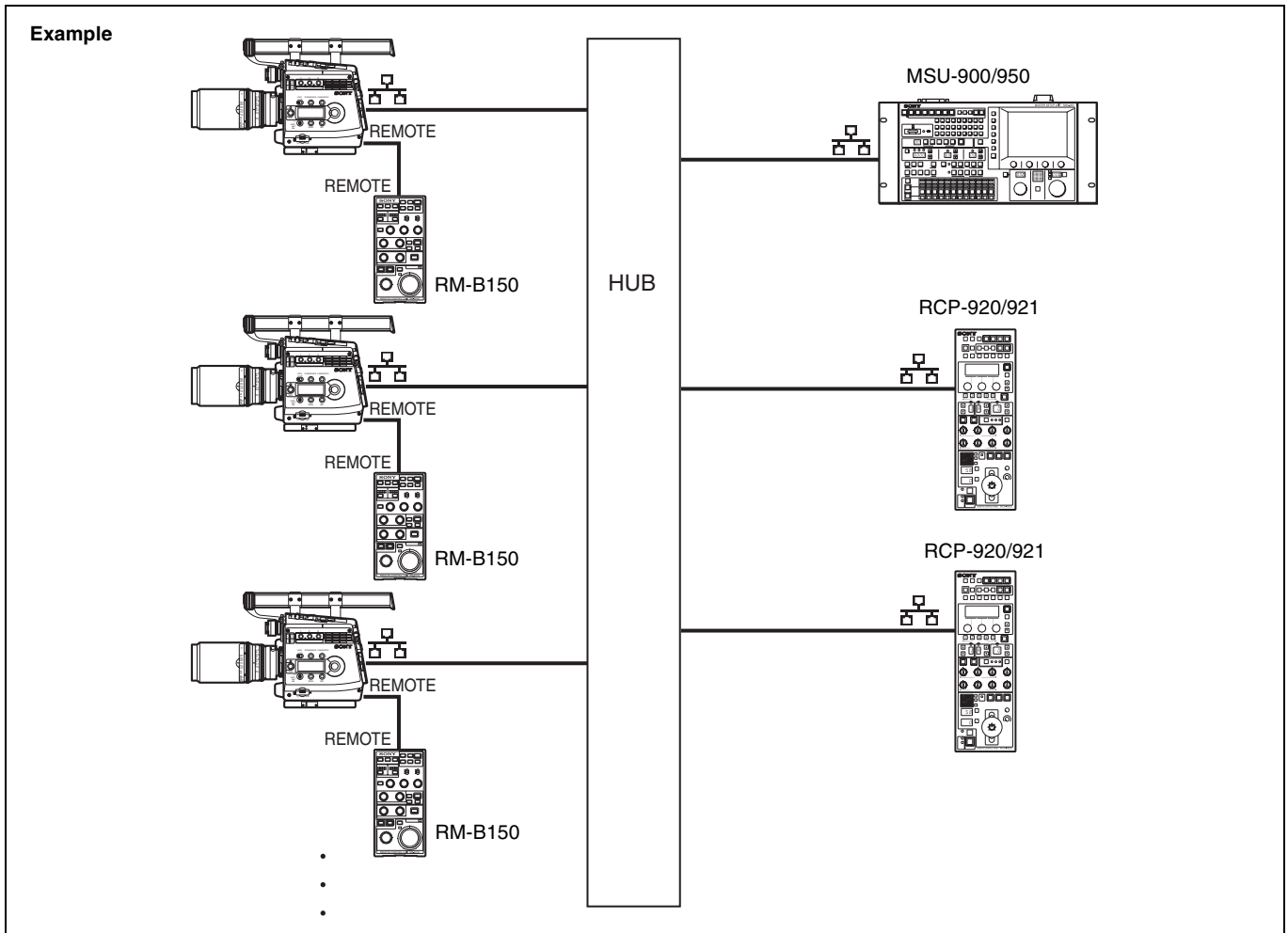

Parameter Settings

Settings on the camera

Set the communication parameters using the NETWORK menu.

page	Item	Setting in Bridge mode	Setting in Multi mode
<IP ADDR SET>	HOST IP ADDRESS	IP address specific to the camera	←
	SUBNET MASK	Value corresponding to the network environments in use	←
	DEFAULT GATEWAY	Value corresponding to the network environments in use	←
<ETHER I/F CONF>	AUTO NEGOTIATION	ON ¹⁾ or OFF	←
	CONNECT SPEED	No setting required if AUTO NEGOTIATION is set to ON. For the OFF setting, select 10M or 100M.	←
	DUPLEX MODE	Select HALF or FULL.	←
<700PTP SETTING>	NS MODE	BRIDGE	MCS
	CAMERA NO.	No setting required	ID number specific to the camera
	MASTER IP ADDRESS	Set the IP address of the MSU-900/950 connected.	Set the IP address of the master MSU-900/950.

1) While the connection may be steady with the ON setting, the performances are improved with an OFF setting for the collateral condition.

Settings on the MSU-900/950

Set the unit to Engineer mode and set the communication parameters, using the Ethernet Configuration menu.

For details on operations, refer to the Operation Manual of the MSU-900/950.

Menu	Item	Setting in Bridge mode	Setting in Multi mode	
			Master unit	Subordinate unit(s)
Connection	Mode selection	Bridge	MCS	
	Target IP SET	IP addresses of the connected cameras	No setting required	
	Master IP SET	No setting required		IP address of the master unit
	Master/Client selection	No setting required	Client	←
	MSU No.	No setting required	1	2
Negotiation	Negotiation	AUTO or OFF	←	←
	Speed	No setting required if Negotiation is AUTO. For the OFF setting, select 10M or 100M.	←	←
	Duplex	No setting required if Negotiation is AUTO. For the OFF setting, select HALF or FULL.	←	←
IP Address Setting	IP Address	IP address specific to the MSU	←	←
	Net Mask	Value corresponding to the network environments in use	←	←
	Gateway Address	Value corresponding to the network environments in use	←	←

Notes on Ethernet connection

- For stable operations of the connected devices, use the system in a local network, without connecting to the Internet.
- Do not connect any device to the local network other than the system units for this camera.

Recommended remote control devices for which operation tests have been made

Sony made

- MSU-900/950
- RM-B150
- RM-B750
- RCP-920/921

Equipment from other vendors

HUB CentreCOM FS909M-PS

Warning/Error Messages

If battery power is low or a problem occurs at power on or during operation, a warning is given by an indicator flashing or various alarm indications.

Viewfinder screen		Subdisplay	RUN indicator	Meaning
Basic status display (page 39)	Message			
BATT 12 V flashing		BATT 12 V flashing	Flashing	Voltage of the 12 V power becomes low, reaching the specified NEAR END value.
BATT 12 V quick flashing		BATT 12 V quick flashing	Quick flashing	Voltage of the 12 V power becomes too low, reaching the specified END value.
BATT 24 V flashing		BATT 24 V flashing	Flashing	Voltage of the 24 V power becomes low, reaching the specified NEAR END value.
BATT 24 V quick flashing		BATT 24 V quick flashing	Quick flashing	Voltage of the 24 V power becomes too low, reaching the specified END value.
	TEMPERATURE CARE			Temperature inside the camera raises.
	TEMPERATURE WARNING			Temperature inside the camera raises to the limit.
	SHUTDOWN CAMERA			The camera must be turned off for safety.
	OHB/SIDE FAN NG!			The fan near the CCD or the fan near the side panel stops.
	PS FAN NG!			The fan near the power unit stops.
CAM?	OHB NG!			Abnormality of the CCD unit
CAM?	AD BOARD NG!			Abnormality of the AD board
CAM?	DPR BOARD NG!			Abnormality of the DPR board
CAM?	VDA BOARD NG!			Abnormality of the VDA board
CAM?	TR BOARD NG!			Abnormality of the TR board
CAM?	AT BOARD NG!			Abnormality of the AT board
	I/F BOX NG!		Quick flashing	An unknown interface box is connected.
	UNKNOWN RECORDER		Quick flashing	An unknown recorder is connected.
	VTR ALARM			Alarm occurs at the SRW-1.
	VTR WARNING			Warning occurs at the SRW-1.

Precautions

Use and Storage

Do not subject the unit to severe shocks

The internal mechanism may be damaged or the body warped.

After use

Always turn off the power.

Before storing the unit for a long period

Remove the battery pack.

Use and storage locations

Store in a level, ventilated place. Avoid using or storing the unit in the following places:

- Places subject to temperature extremes
- Very damp places
- Places subject to severe vibration
- Near strong magnetic fields
- In direct sunlight or close to heaters for extended periods

To prevent electromagnetic interference from portable communications devices

The use of portable telephones and other communications devices near this unit can result in malfunctions and interference with audio and video signals.

It is recommended that the portable communications devices near this unit be powered off.

Note on laser beams

Laser beams may damage the CCDs. If you shoot a scene that includes a laser beam, be careful not to let the laser beam be directed into the lens of the camera.

Condensation

If you move the camera from a very cold place to a warm place, or use it in a damp location, condensation may form on the lens or inside the camera.

The camera has no built-in condensation indicator. If you find condensation on the body or lens, switch the camera off and wait for the condensation to disappear for about one hour.

Phenomena Specific to CCD Image Sensors

The following phenomena that may appear in images are specific to CCD (Charge Coupled Device) image sensors. They do not indicate malfunctions.

White flecks

Although the CCD image sensors are produced with high-precision technologies, fine white flecks may be generated on the screen in rare cases, caused by cosmic rays.

This is related to the principle of CCD image sensors and is not a malfunction.

The white flecks especially tend to be seen

- when operating at a high environmental temperature
- when you have raised the master gain (sensitivity)

This product has a compensation function and the problem may be alleviated by automatic black balance adjustment (*see page 34*).

Smear

When an extremely bright object, such as a strong spotlight or flashlight, is being shot, vertical tails may be produced on the screen, or the image may be distorted.

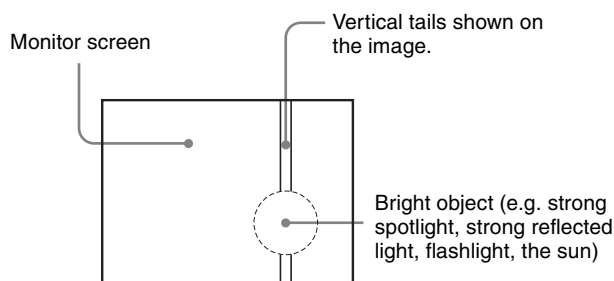

Aliasing

When fine patterns, stripes, or lines are shot, they may appear jagged or flicker.

About a “Memory Stick”

What is “Memory Stick”?

“Memory Stick” is a new compact, portable and versatile IC (Integrated Circuit) recording medium with a data capacity that exceeds a floppy disk. “Memory Stick” is specially designed for exchanging and sharing digital data among “Memory Stick” compatible products. Because it is removable, “Memory Stick” can also be used for external data storage.

“Memory Stick” media are available in three sizes: standard size, compact “Memory Stick Duo” size, and the smallest “Memory Stick Micro” (“M2”¹⁾) size. Once attached to a Memory Stick Duo adapter, a “Memory Stick Duo” is the same size as a standard “Memory Stick,” and as a result can be used with products requiring a standard “Memory Stick.” Also, once attached to a standard-size M2 adaptor, a “Memory Stick Micro” is the same size as a standard “Memory Stick,” and as a result can be used with products requiring a standard “Memory Stick.”

1) “M2” is an abbreviation for “Micro Memory Stick.”

Types of “Memory Stick”

“Memory Stick” is available in the following six types to meet various requirements in functions.

“Memory Stick”

Stores any type of data except copyright-protected data that requires the “MagicGate” copyright protection technology.

“MagicGate Memory Stick”

Equipped with the “MagicGate” copyright protection technology.

“Memory Stick” (“MagicGate”/High-Speed Transfer Compatible)

Equipped with “MagicGate” copyright protection technology and allows high-speed data transfer. This type of “Memory Stick” can be used with products requiring a “Memory Stick,” “MagicGate Memory Stick,” and “Memory Stick PRO.”¹⁾

1) Operation is not guaranteed for all of the compliant products. (Some products may not accept this type of “Memory Stick.”)

This camera is not compliant with high-speed data transfer with this type of “Memory Stick.”

“Memory Stick-ROM”

Stores pre-recorded, read-only data. You cannot record on “Memory Stick-ROM” or erase the pre-recorded data.

“Memory Stick” (with Memory Select Function)

Composed of multiple 128 MB memory units. The mechanical switch at the back of the “Memory Stick” allows you to select the memory unit to be used depending on usage. The memory units cannot be used simultaneously and continuously.

“Memory Stick PRO”

“Memory Stick” with “MagicGate” copyright protection technology, exclusive for “Memory Stick PRO”-compliant products.

Usable type of “Memory Stick”

You can use a “Memory Stick PRO” with this camera. The “Memory Stick PRO Duo” can also be used without using the Memory Stick Duo adaptor.

This camera is not compliant with Parallel mode of “Memory Stick.”

The camera operations have been checked using “Memory Stick PRO” media up to 8GB.

Operations checked with:

- MSH-128
- MSX-512S
- MSX-M2GS
- MSX-M4GS
- MSX-M8GS

Note on data read/write speed

Data read/write speed may vary depending on the combination of the “Memory Stick” and “Memory Stick” compliant product you use.

What is “MagicGate”?

“MagicGate” is copyright protection technology that uses encryption technology.

Before using a “Memory Stick”

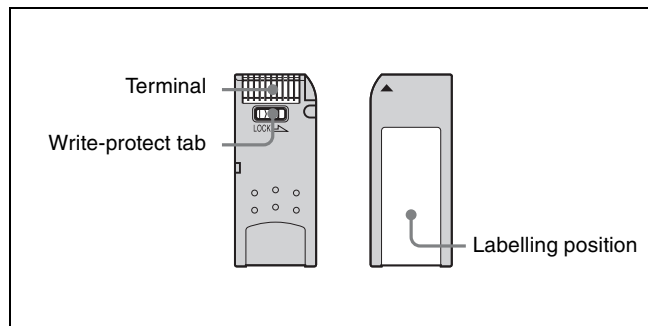

- When you set the “Memory Stick” erasure prevention switch to “LOCK,” data cannot be recorded, edited, or erased.
- Data may be damaged if:

- You remove the “Memory Stick” or turn off the unit while it is reading or writing data.
- You use the “Memory Stick” in a location subject to the effects of static electricity or electric noise.
- We recommend that you make a backup copy of important data that you record on the “Memory Stick”.

Notes

- Do not attach anything other than the supplied label to the “Memory Stick” labeling position.
- Attach the label so that it does not stick out beyond the labeling position.
- Carry and store the “Memory Stick” in its case.
- Do not touch the connector of the “Memory Stick” with anything, including your finger or metallic objects.
- Do not strike, bend, or drop the “Memory Stick”.
- Do not disassemble or modify the “Memory Stick”.
- Do not allow the “Memory Stick” to get wet.
- Do not use or store the “Memory Stick” in a location that is:
 - Extremely hot, such as in a car parked in the sun
 - Under direct sunlight
 - Very humid or subject to corrosive substances

- “Memory Stick”,  and “MagicGate Memory Stick” are trademarks of Sony Corporation.
- “Memory Stick Duo” and MEMORY STICK DUO are trademarks of Sony Corporation.
- “Memory Stick PRO” and MEMORY STICK PRO are trademarks of Sony Corporation.
- “Memory Stick PRO Duo” and MEMORY STICK PRO DUO are trademarks of Sony Corporation.
- “Memory Stick-ROM” and MEMORY STICK-ROM are trademarks of Sony Corporation.
- “MagicGate Memory Stick” is trademark of Sony Corporation.
- “MagicGate” and MAGICGATE are trademarks of Sony Corporation.

If the access indicator is lit in red

Data is being read from or written to the “Memory Stick”. At this time, do not shake the product or subject it to shock. Do not turn off the power of the product or remove the “Memory Stick.” This may damage the data.

Precautions

- To prevent data loss, make backups of data frequently. In no event will Sony be liable for any loss of data.
- Unauthorized recording may be contrary to the provisions of copyright law. When you use a “Memory Stick” that has been pre-recorded, be sure that the material has been recorded in accordance with copyright and other applicable laws.
- The “Memory Stick” application software may be modified or changed by Sony without prior notice.
- Note that there are certain restrictions on recording stage performances and other entertainment events, even if they are recorded for personal use only.

Specifications

Camera Head

General

Power requirements	DC 10.5 to 17 V
Power consumption	Approx. 56 W with 23.98 PsF (not including lens, viewfinder)
Operating temperature	0°C to +40°C (32°F to 104°F)
Storage temperature	-20°C to +60°C (-4°F to +140°F)
Mass	Approx. 5 kg (11 lb) (camera head only)

Imager

Imager	2/3-type Progressive Interline CCD
Method	3-CCD, RGB
Aspect ratio	16:9
Effective resolution	1920 (horizontal) × 1080 (vertical)

Electrical characteristics

Sensitivity (at 2000 lx with 89.9% reflectivity)	T10 with 23.98 PsF (with BASE SETTING>D-RANGE>NORMAL) T11 with 23.98 PsF (with BASE SETTING>D-RANGE>EXTEND)
ISO sensitivity	ISO 400 (with BASE SETTING>D-RANGE>NORMAL) ISO 530 (with BASE SETTING>D-RANGE>EXTEND)
Registration	0.02% for total area (not including lens distortion)
Geometric distortion	Negligible (not including lens distortion)
Horizontal resolution	1000 TV lines (at center of screen) 5% or higher modulation

Optical system specifications

Spectral system	F1.4 prism
Built-in filters	Color temperature conversion filters 3200K, 4300K, 5600K, 6300K, ND0.3 ($1/2$ ND)
ND filters	Clear, ND0.6 ($1/4$ ND), ND1.2 ($1/16$ ND), ND1.8 ($1/64$ ND), CAP

Input/output connectors

DC IN	LEMO 8-pin male (1), DC 10.5 to 17 V, 20 to 30 V
DC OUT	12 V: 11-pin (1), DC 12 V, 4 A maximum 24 V: 3-pin (1), DC 24 V, 5.5 A maximum (The usable current may be limited depending on the load and input conditions.)
VF1, VF2	20-pin (1 each)
LENS	12-pin (1)
TEST OUT	BNC type (1), VBS/HD Y
MONITOR OUT	HD SDI 4:2:2, BNC type (2)
GENLOCK IN	BNC type (1)
REMOTE	8-pin (1)
EXT I/O	LEMO 5-pin, female (1)
$\frac{\square}{\square}$ (network)	RJ-45 type (1), 10BASE-T, 100BASE-TX

Supplied accessories

Interface box (1)
Assistant panel (1)
Assistant panel cable (1)
Assistant panel hanger (1)
+B4×8 screws (4)
Center handle (1)
L handle (1)
Riser plate (1)
Power cable connector (LEMO 8-pin) (1)
Operation manual (1)

Dimensions

With the L handle attached

Unit: mm (inches)

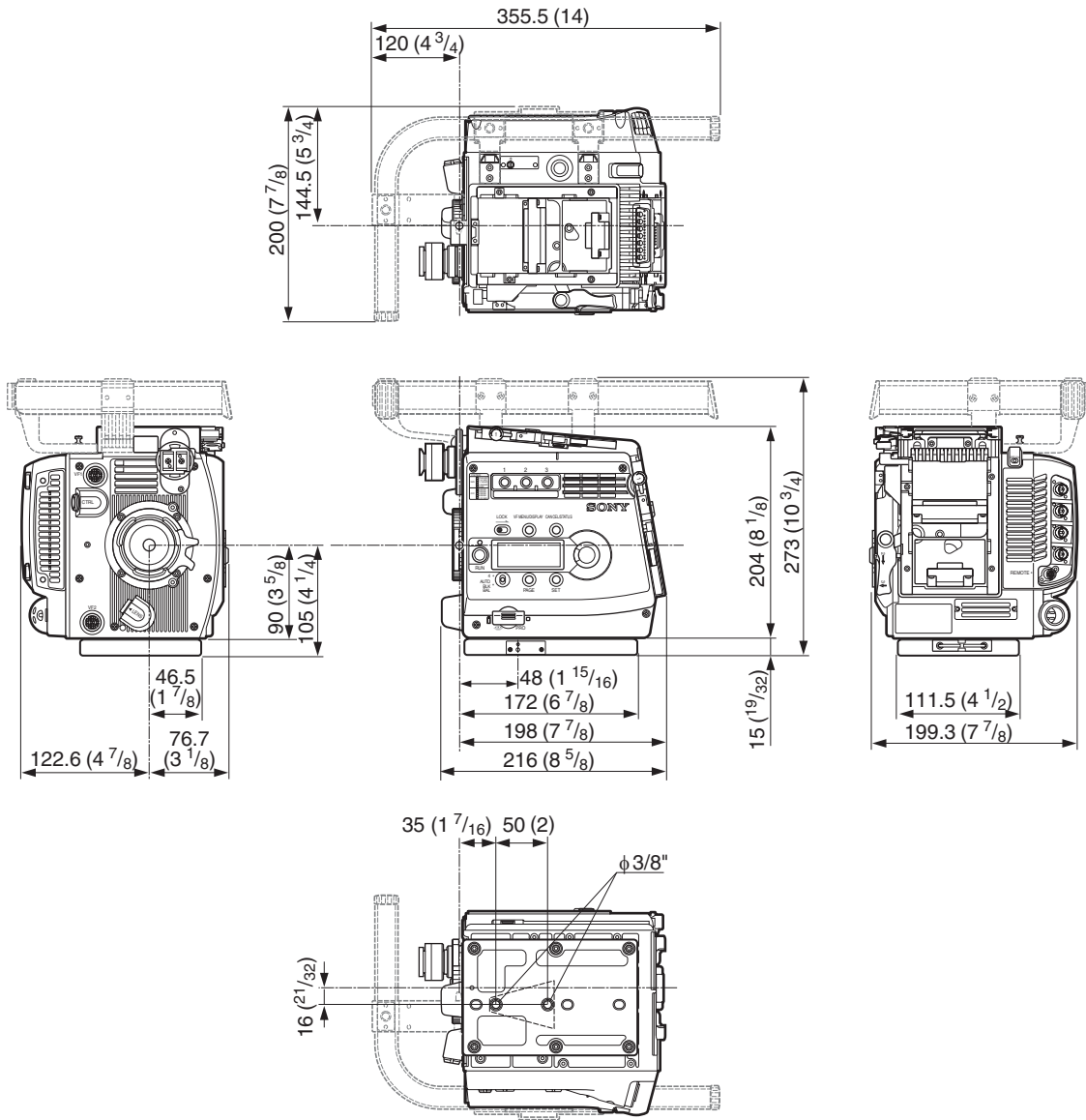

Appendixes

Interface Box (Supplied)

General

Power requirements	DC 10.5 to 17 V
Operating temperature	0°C to +40°C (32°F to 104°F)
Storage temperature	-20°C to +60°C (-4°F to +140°F)
Dimensions	138 × 104 × 79 mm (5 ¹ / ₂ × 4 ¹ / ₈ × 3 ¹ / ₈ inches)
Mass	Approx. 560 g (1 lb 4 oz)

Input/output connectors

AUDIO IN CH1, CH2	XLR 3-pin, female (1 each) AUDIO switch in MIC: -44 dBu, balanced AUDIO switch in LINE: +4 dBu, balanced Phantom +48V, balanced
DC IN	XLR type, 4-pin, male (1)
HD SDI OUT A/B	BNC type (1 each), Dual Link

Optional Accessories

HD Electronic Viewfinder
HDVF-20A (2-inch type, monochrome)
HDVF-C35W (3.5-inch type, color)
HDVF-C730W (6.3-inch type, color)
HDVF-C950W (9-inch type, color)

Remote Control Unit

RM-B750
RM-B150

“Memory Stick”

Design and specifications are subject to change without notice.

Note

Always verify that the unit is operating properly before use. SONY WILL NOT BE LIABLE FOR DAMAGES OF ANY KIND INCLUDING, BUT NOT LIMITED TO, COMPENSATION OR REIMBURSEMENT ON ACCOUNT OF THE LOSS OF PRESENT OR PROSPECTIVE PROFITS DUE TO FAILURE OF THIS UNIT, EITHER DURING THE WARRANTY PERIOD OR AFTER EXPIRATION OF THE WARRANTY, OR FOR ANY OTHER REASON WHATSOEVER.

Index

A

ABNORMAL display 40
AC power 24
accessory clamp lever 17
accessory mount lever 17
Accessory pockets 11
Accessory receptacles 10
Aliasing 92
ALL menu 51
Angle Compensation mode 29, 46
Assignable buttons 12, 33
Assignable switch 12, 33
ASSISTANT PNL 30, 59
AUDIO IN CH-1/CH-2 connectors 15
Audio input selection switches 15
AUTO BLK BAL switch 12, 34
AUTO IRIS 67
AUTO SETUP 35, 66
AUTO WHITE 35
Automatic black balance 34
Automatic white balance 34
AUX connector 15

B

BASE SETTING 27, 65
Basic Operation Modes 26
BATT ALARM SET 68
BATTERY ALARM 43, 59
battery pack 24
BKP-L551 24
BLACK GAMMA 61
BLACK SHADING 66
BOARD STATUS 74
Box cursor 43
BP-GL95 24
BRIDGE 89
Bridge mode 88
brightness of the subdisplay 33
built-in clock 25

C

CAM BARS 38
CAM POWER switch 11
CAMERA connector 15
CANCEL/STATUS button 13, 27
CC filters 30
center handle 23
Center marker 41
CHAR/MARK MIX 58
Cine mode 26
COLOR 36

COLOR SPACE 27
color temperature 31
COMPENSATION 46
Condensation 92
CONTENTS page 53
CONTROL PANEL connector 10
CURSOR 43, 57
Custom mode 26
CvpFileEditor 48

D

Data Change mode (subdisplay) 28
DATE 25, 68
DAYLIGHT 31
DC IN connector 11, 15
DC OUT 12V connector 12
DC OUT 24V connector 12
DETAIL 1 62
DETAIL 2 63
DIAGNOSIS menu 52, 74
DOCK STATUS 74
DOWN CONVERTER 67
D-RANGE 27

E

EDIT FUNCTION 75
Electrical characteristics 95
electrical gain 31
ETHER I/F CONF 70, 89
EXT I/O connector 11

F

FAN MODE 48
Fan Operation mode 32
FILE menu 52, 71
FILE PRESET 73
flange focal length 20
Focus reference mark 12, 13
FORMAT SEL 30
FRAME 50
FRAME RATE 45
frame rate 29
FUNCTION display 41

G

gain 31
GAIN ASSIGN 45, 59
Gain Compensation mode 46
GAMMA 47, 61
GENLOCK IN connector 14

H

HD Portable Digital Recorder 19
HD-SDI A/B connectors 15

Hyper Gamma 47

I

IMAGE INVERT 49
image-inversion function 49
Imager 95
Interface Box 15
IP ADDR SET 70, 89

K

KNEE 62

L

L handle 11, 23
LEGACY 87
LENS connector 10
LENS FILE 60, 72, 82
lens file 31
Lens files 78
Lens mount cap 10
Level vial 11
LOCK switch 12, 28
lock-release knob 17

M

MAINTENANCE menu 51, 65
MARKER DISPLAY 41, 56
MARKER SETTING 42, 56
MCS 89
Measure hook 12
Memory Stick section 13
MENU SEL/ENTER dial 13, 27
MIX TYPE 37
MIX 37
MONI GAMMA ENABLE 37
MONI HD-SDI 36
MONITOR OUT HD SDI connectors 14
MONITOR OUTPUT 36, 57
MSU-900/950 88
Multi (MCS) mode 88
MULTI MATRIX 64

N

ND filters 30
ND offset 84
network connector 11
NETWORK menu 52, 70
NETWORK RESET 70

O

OHB FILE 73, 84
OHB MATRIX 66
OPERATION menu 51, 55

OPERATOR FILE 46, 60, 71, 82
Operator file 78
Optical system specifications 95
OTHERS 1 38, 48, 49, 68
OTHERS 2 69
OUTPUT FORMAT 50, 67

P

PAGE button 13, 27
PAINT menu 51, 60
PB MIX SETTING 37, 58
PB MIX 37
PB/MONI GAMMA 36, 57
PB 37
Phenomena Specific to CCD Image
Sensors 92
PLD VERSION 74
Power indicators 11
POWER SAVE 67

R

REFERENCE 72, 84
Reference file 78
REMOTE connector 14
reset a specific item of the reference file
86
RM VIDEO 36
RM-B150 45
RM-B750 87
ROM VERSION 74
RUN button 12
RUN indicator 14, 91

S

safety release tab 18
Safety zone marker 41
SATURATION 61
SCAN 50
SCENE FILE 65, 71, 83
Scene files 78
SELECT FPS 50
SET button 13, 27
SHOOT MODE 27
SHUTTER ASSIGN 29, 58
SHUTTER/FPS 45, 64
SIGNAL 50
SKIN DETAIL 63
S-LOG 47
Smear 92
SRW-1 19
STANDARD 84
Standard Gamma 47
status indications 39
STEP 45
Step Shutter mode 28
Subdisplay 13

SW STATUS 60
SWITCH ASSIGN 44, 59

T

tape remaining 32
TEST OUT 36
TEST OUT connector 14
time code 32
TOP MENU screen 53
tripod 22
Tripod receptacles 13
TUNGSTEN 31

U

USER GAMMA 48, 72, 84
User Gamma 47
USER MATRIX 63
USER menu 51
USER MENU CUSTOMIZE menu 51,
75
User-Gamma file 79

V

VAR 45
Variable Shutter mode (ECS) 28
VF DETAIL 42, 57
VF DISPLAY 40, 55
VF MENU/DISPLAY button 13, 27
VF1 connector 10
VF2 connector 10
video format 30, 49
VIDEO LEVEL 61
Viewfinder shoe 10

W

white balance memory 31
WHITE CLIP 62
White flecks 92
WHITE SHADING 66
WIPE 37
Wrench box 14

Z

ZEBRA 42, 57
OHB file 79

Symbols

'!' IND 40, 56

Numerics

5600K 31
700PTP SETTING 70, 89



The material contained in this manual consists of information that is the property of Sony Corporation and is intended solely for use by the purchasers of the equipment described in this manual.

Sony Corporation expressly prohibits the duplication of any portion of this manual or the use thereof for any purpose other than the operation or maintenance of the equipment described in this manual without the express written permission of Sony Corporation.

Sony Corporation

<http://www.sony.net/>

F23 (SY)
3-214-586-01(1)



Printed on 70% or more recycled paper.

Printed in Japan
2007.05.13
© 2007