

SONY

SONY®

HD CAMCORDER

HDW-F900

HDW-F900H

HDW-F900/F900H

HDCAM



Tele-File



MEMORY STICK™



OPERATION MANUAL
1st Edition (Revised 3)

English

WARNING

To prevent fire or shock hazard, do not expose the unit to rain or moisture.

To avoid electrical shock, do not open the cabinet. Refer servicing to qualified personnel only.

For the customers in U.S.A.

This equipment has been tested and found to comply with the limits for a Class A digital device, pursuant to Part 15 of the FCC Rules. These limits are designed to provide reasonable protection against harmful interference when the equipment is operated in a commercial environment. This equipment generates, uses, and can radiate radio frequency energy and, if not installed and used in accordance with the instruction manual, may cause harmful interference to radio communications. Operation of this equipment in a residential area is likely to cause harmful interference in which case the user will be required to correct the interference at his own expense.

You are cautioned that any changes or modifications not expressly approved in this manual could void your authority to operate this equipment.

The shielded interface cable recommended in this manual must be used with this equipment in order to comply with the limits for a digital device pursuant to Subpart B of Part 15 of FCC Rules.

For the customers in Europe

This product with the CE marking complies with the EMC Directive (89/336/EEC) issued by the Commission of the European Community.

Compliance with this directive implies conformity to the following European standards:

- EN55103-1: Electromagnetic Interference (Emission)
- EN55103-2: Electromagnetic Susceptibility (Immunity)

This product is intended for use in the following Electromagnetic Environment(s):

E1 (residential), E2 (commercial and light industrial), E3 (urban outdoors) and E4 (controlled EMC environment, ex. TV studio).

Pour les clients européens

Ce produit portant la marque CE est conforme à la Directive sur la compatibilité électromagnétique (EMC) (89/336/CEE) émise par la Commission de la Communauté européenne.

La conformité à cette directive implique la conformité aux normes européennes suivantes:

- EN55103-1: Interférences électromagnétiques (émission)
- EN55103-2: Sensibilité électromagnétique (immunité)

Ce produit est prévu pour être utilisé dans les environnements électromagnétiques suivants:

E1 (résidentiel), E2 (commercial et industrie légère), E3 (urbain extérieur) et E4 (environnement EMC contrôlé ex. studio de télévision).

Für Kunden in Europa

Dieses Produkt besitzt die CE-Kennzeichnung und erfüllt die EMV-Direktive (89/336/EEC) der EG-Kommission.

Die Erfüllung dieser Direktive bedeutet Konformität für die folgenden Europäischen Normen:

- EN55103-1: Elektromagnetische Interferenz (Emission)
- EN55103-2: Elektromagnetische Empfindlichkeit (Immunität)

Dieses Produkt ist für den Einsatz unter folgenden elektromagnetischen Bedingungen ausgelegt:

E1 (Wohnbereich), E2 (kommerzieller und in beschränktem Maße industrieller Bereich), E3 (Stadtbereich im Freien) und E4 (kontrollierter EMV-Bereich, z.B. Fernsehstudio)

Table of Contents

Chapter 1 Overview

1-1	Features	1-1
	1-1-1 Camera Features	1-1
	1-1-2 VTR Features	1-4
1-2	Example of System Configuration	1-6
1-3	Precautions	1-8

Chapter 2 Locations and Functions of Parts and Controls

2-1	Power Supply	2-1
2-2	Accessory Attachments	2-3
2-3	Audio Functions	2-5
2-4	Shooting and Recording/Playback Functions	2-13
2-5	Setup Menu Operating Section	2-27
2-6	Time Code System	2-29
2-7	Warnings and Indications	2-35
2-8	Warnings and Indications on the Display Panel	2-38
2-9	Indicators on the Viewfinder (HDVF-20A (not supplied))	2-42

Chapter 3 Recording and Playback

3-1	About Cassettes	3-1
	3-1-1 Loading and Unloading a Cassette	3-1
	3-1-2 Preventing Accidental Erasure	3-4
3-2	Recording	3-5
	3-2-1 Basic Procedure	3-5
	3-2-2 Continuous Recording	3-9
3-3	Checking the Recording — Playback	3-13
	3-3-1 Checking the Last Three Seconds of the Recording — Recording Review	3-14

(Continued)

3-3-2	Checking the Recording on the Color Video Monitor — Playback in Color	3-14
3-3-3	Checking the Camera Picture on the Viewfinder and/or Color Video Monitor	3-15
3-4	Tele-File	3-16

Chapter 4 Adjustments and Settings for Recording

4-1	Adjusting the Black Balance and the White Balance	4-1
4-1-1	Adjusting the Black Balance	4-2
4-1-2	Adjusting the White Balance	4-5
4-2	Setting the Electronic Shutter	4-9
4-2-1	Shutter Modes	4-9
4-2-2	Selecting the Shutter Mode and Speed	4-10
4-3	Adjusting the Audio Level	4-13
4-4	Setting the Time Data	4-17
4-4-1	Setting the User Bits	4-17
4-4-2	Setting the Time Code	4-19
4-4-3	Entering the Real Time in the VITC	4-21
4-4-4	Synchronizing the Time Code	4-23
4-5	Setup Menu Display on the Viewfinder Screen	4-28
4-5-1	Basic Use of the Setup Menu	4-31
4-6	Status Display on the Viewfinder Screen	4-34
4-6-1	Layout of the Status Display on the Viewfinder Screen	4-34
4-7	Using the USER Menu	4-38
4-7-1	Setting Desired Menu Pages on the USER Menu	4-38
4-7-2	Setting Desired Items on a USER PAGE	4-42
4-7-3	Displaying the USER Menu	4-45
4-8	Setup Using the OPERATION Menu	4-47
4-8-1	Selecting the Display Items	4-48
4-8-2	Selecting the Items for Which the '!' IND is to Light	4-50
4-8-3	Setting the Marker Display	4-55

4-8-4	Setting the GAIN Selector Values	4-58
4-8-5	Setting the Viewfinder	4-60
4-8-6	Setting the Automatic Iris	4-62
4-8-7	Setting the Battery	4-64
4-8-8	Setting the D5600K Mode, Assignable Switches and PB VIDEO	4-66
4-8-9	Saving or Reading Setup Data to or from the Memory Stick	4-69
4-8-10	Selecting the Lens File	4-70
4-9	Paint Menu	4-72
4-10	Maintenance Menu	4-85
4-11	Using the Memory Stick	4-91
4-11-1	Handling the Memory Stick	4-91
4-11-2	Using Data on the Memory Stick — in Case of an OPERATOR File	4-93

Chapter 5 Setting Up the Camcorder

5-1	Power Supply	5-1
5-1-1	Using a BP-L60A Battery Pack	5-1
5-1-2	Avoiding Breaks in Operation Due to Dead Batteries	5-4
5-1-3	Using an AC Adaptor	5-5
5-1-4	Using the Anton Bauer Ultralight System	5-6
5-2	Adjusting the Viewfinder	5-7
5-2-1	Adjusting the Viewfinder Position	5-7
5-2-2	Detaching the Viewfinder	5-9
5-3	Mounting the Lens	5-11
5-4	Adjusting the Flange Focal Length	5-12
5-5	Audio Input System	5-14
5-5-1	Using the Supplied Microphone	5-14
5-5-2	Using an External Microphone	5-17
5-5-3	Attaching a UHF Portable Tuner (for a UHF Wireless Microphone System)	5-22
5-5-4	Connecting Line Input Audio Equipment	5-24

(Continued)

5-6	Tripod Mounting	5-25
5-7	Attaching the Shoulder Strap	5-27
5-8	Adjusting the Shoulder Pad Position	5-29
5-9	Putting On the Rain Cover	5-30
5-10	Connecting the Remote Control Unit	5-33

Chapter 6 Maintenance

6-1	Testing the Camcorder Before Shooting	6-1
6-1-1	Preparations for Testing	6-1
6-1-2	Testing the Camera	6-2
6-1-3	Testing the VTR	6-6
6-2	Maintenance	6-10
6-2-1	Cleaning the Video Heads	6-10
6-2-2	Cleaning the Viewfinder	6-10
6-3	Operation Warnings	6-14

Appendix

Specifications	A-1
Video Camera Section	A-2
VTR Section	A-3
Supplied Accessories	A-6
Recommended Additional Equipment	A-6
Glossary	A-9
Index	I-1

1-1 Features

The HDW-F900 HD Camcorder combines a HD color video camera, of which the effective picture elements are 1920(H) x 1080(V) and which uses 2/3-inch FIT¹⁾ CCD²⁾ imagers with 2,200,000 picture elements, with an HDCAM portable videocassette recorder. The camcorder allows you to perform recording and playback with various formats, covering 50I, 30P, 29.97P, 25P, 24P and 23.98P as well as 60I and 59.94I formats. The introduction of a new integrated circuit technology (LSI) for processing HD digital signals improves the image quality even further and simplifies setup (initialization) operations.

1-1-1 Camera Features

The features of the HDW-F900 camera are described below.

- 2/3-inch FIT CCDs with 2,200,000 picture elements provide a compact and lightweight unit with excellent image quality.
- Existing 2/3-inch lenses can be used.
- A new integrated circuit technology of the digital signal processing has improved picture quality and functionality.
- The camcorder can operate with any one of 8 different formats, 59.94I, 60I, 30P, 29.97P, 50I, 25P, 24P and 23.98P.
- The 12-bit AD converter has greatly improved picture quality.
- An new AD board and optimized signal processing improves the reproduction of brightest part in P format.
- You can load a user gamma data table created on a personal computer to the camcorder via a Memory Stick³⁾. This allows the user to change the gamma settings.
- A setup menu enables you to control features such as status displays, messages, and markers; to select various types of settings; to toggle switches; and to operate a Memory Stick.

1) FIT: Frame Interline Transfer

2) CCD: Charge-Coupled Device

3) "Memory Stick" is a trademark of Sony Corporation.

- The USER MENU CUSTOMIZE menu allows you to create your own custom menu.
- Five scene files are set in one group. A maximum of 20 groups, that is, a maximum 100 scene files, can be saved in a Memory Stick.
- You can select a mode that allows the camcorder to output images seen through a camera to the viewfinder and the MONITOR OUT connector during playback.
- Blur-free shooting is ensured by a built-in, high-performance electronic shutter that provides a variety of modes, such as ECS¹⁾ mode which reduces flickering on the monitor screen and S-EVS²⁾ mode which improves vertical resolution.
- Selectable video gain ensures a noise-free image.
- A simple switch operation enables automatic adjustment of the black set, black balance, and white balance. Memory functions make it easy to replicate the white balance setting appropriate for the lighting conditions.
- Character display functions on the viewfinder indicate switch settings, automatic black and white balance adjustment, status indications, and warnings.
- The warning system uses various types of warning indicators and sounds to inform you of VTR faults, end of tape, low battery, etc.
- The camcorder is equipped with a dual-wheel filter disk for adjusting the filter setting to the shooting and lighting conditions.
- Override function which makes fine adjustment of the reference value for brightness of automatic iris control is provided.
- A built-in circuit produces a color bar signal for easy adjustment of the color monitor.
- The remote control unit controls camera functions and VTR functions.
- Setup data specified by the camera operator, including the various marker settings, can be stored in the camcorder itself and on a memory stick as an operator file, and then can be recalled.

1) ECS: Extended Clear Scan

2) S-EVS: Super Enhanced Vertical definition System

-
- Setup data specified by video engineers, including the various detail settings, can be stored in the camcorder itself and on a Memory Stick as a reference file, and then can be recalled. It is possible to shorten time for setting with duplicating the stored reference file to the other cameras through the Memory Stick.
 - Correction value to use a lens extender and for each lens can be stored as a lens file, and then can be recalled. It is possible to shorten time for adjustment when replacing the lens.
 - A high-performance viewfinder is adjustable forward, backward, and sideways, and has a full range of auxiliary equipment.

1-1-2 VTR Features

The VTR features of this camcorder are described below.

- Use of the HDCAM format allows high performance HD digital recording and playback while preserving the same ease of use as conventional camcorder equipment. Also, recording and playback are allowed in any one of 8 different formats that the camera section supports.
- The same cassette size (S size) as Digital BETACAM can be used to achieve the following long recording times:
Approximately 40 minutes at 30 frames
Approximately 48 minutes at 25 frames
Approximately 50 minutes at 24 frames.
- The recording review function, which automatically rewinds and plays back the last approximately 3 seconds of recording on the tape, enables you to quickly confirm recorded contents.
- No playback adaptor is needed to see the color playback image on the monitor screen.
- The 3 times normal speed search function provides quick positioning of the tape.
- LTC¹⁾ and VITC²⁾ recording and LTC playback can be performed.
- Compatible with the Tele-File³⁾ Memory Label system.
By pressing the RET button on the lens while recording, the timecode valid when you pressed the button is recorded on the MLB-1M-100 memory label (not supplied) attached to the cassette. This is very helpful for management of the cassette tapes and to improve the efficiency of the tape editing.

1) LTC: Longitudinal Time Code

2) VITC: Vertical Interval Time Code

3) Tele-File

The Tele-File system is a non-contact data reading/writing system. It allows a variety of data to be stored on a 1/2-inch tape label with an non-contact IC memory.

- The built-in time code generator can be synchronized with an external generator.
- A lithium battery is the back-up power supply for the built-in time code generator enabling the time code to be held for approximately 5 years without charging the camcorder power supply.
- Optional long-life battery packs are available.
- Pressing the VTR START button on the camcorder or the VTR button on the lens ensures recording continuity from the very next frame.
- Two analog audio input channels and the microphone can be recorded at the same time.
- Connecting the HDCA-901 camera adaptor (not supplied) allows you to input four audio input channels. Also, the HD-SDI signal can be output.

1-2 Example of System Configuration

The diagram below shows a typical configuration of the camcorder for ENG and EFP. In this manual, the HDVF-20A HD Electronic Viewfinder (not supplied) is used to instruct how to operate the unit.

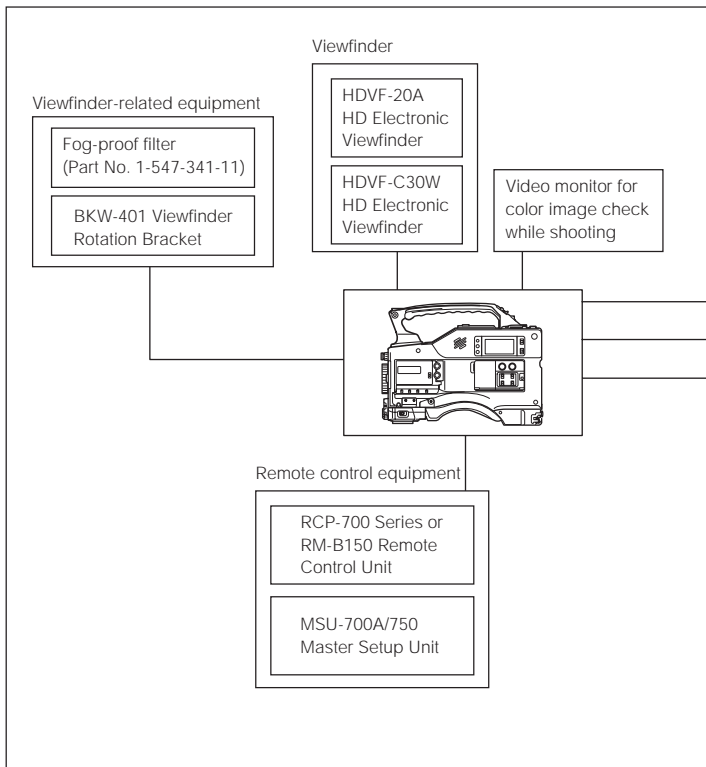

For more information about the fittings, connections, or use of additional equipment and accessories, see Chapter 5 as well as the operation manuals for the connected equipment.

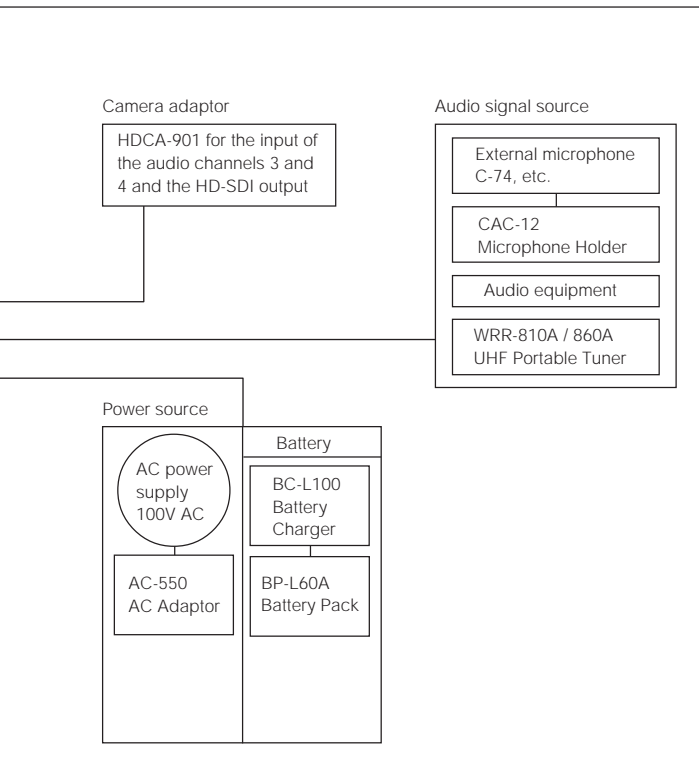

1-3 Precautions

1

Use and Storage

Do not subject the camcorder to severe shocks

The internal mechanism may be damaged or the body warped.

After use

Always turn off the power.

Before storing the camcorder for a long period

Remove the battery pack.

Use and storage locations

Store in a level, ventilated place. Avoid using or storing the camcorder in the following places.

- Places subject to temperature extremes
- Very damp places
- Places subject to severe vibration
- Near strong magnetic fields
- In direct sunlight or close to heaters for extended periods

To prevent electromagnetic interference from portable communications devices

The use of portable telephones and other communications devices near this unit can result in misoperations and interference with audio and video signals.

It is recommended that the portable communications devices near this unit be powered off.

Note on laser beams

Laser beams may damage the CCDs. If you shoot a scene that includes a laser beam, be careful not to let a laser beam become directed into the lens of the camera.

2-1 Power Supply

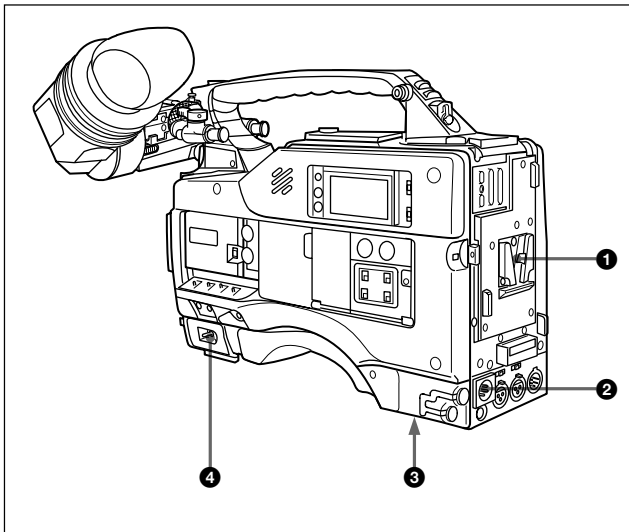

Power supply

❶ Battery attachment

Attach a BP-L60A battery pack.

❷ DC IN (external power input) connector (XLR type, 4-pin, male)

To operate the HDW-F900 using an AC power supply, connect an AC-550 AC Adaptor with the DC output cable supplied with the adaptor.

To use an external battery, connect its DC output cable to the DC IN connector.

(Continued)

③ **BREAKER button**

If excessive current flows within the unit, the breaker is tripped automatically to shut off the power supply and protect the equipment. After performing internal checks or adjustments, use a pointed object such as a pen to press down lightly on this button. If there is no problem, the power will again be supplied.

④ **POWER switch**

This switch turns the main power supply on and off.

2-2 Accessory Attachments

2

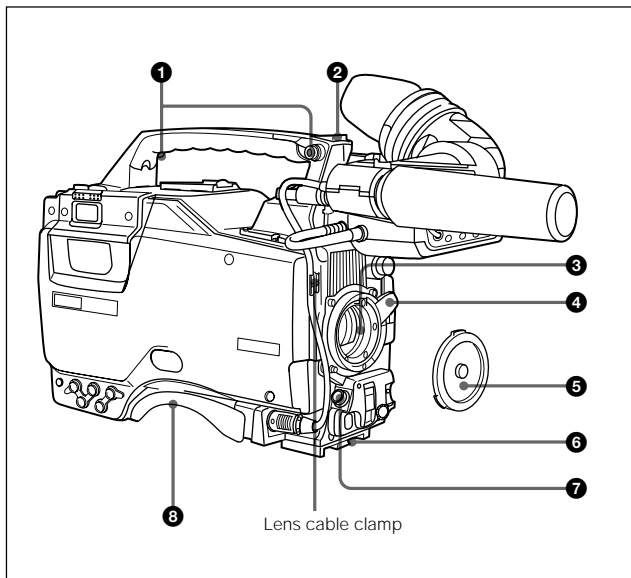

Accessory attachments

❶ Shoulder strap posts

Attach the supplied shoulder strap to these posts.

❷ Light shoe

Attach an optional accessory such as a video light to this shoe.

❸ Lens mount (special bayonet mount)

Use this for mounting the lens.

(Continued)

4 Lens locking lever

After inserting the lens in the lens mount, rotate the lens mount ring with this lever to lock the lens in position.

5 Lens mount cap

Remove this cap by pushing up on the lens locking lever. For protection from dust, always insert this cap when no lens is mounted.

6 Tripod mount

When using the unit on a tripod, attach the supplied tripod adaptor.

7 LENS connector (12-pin)

Fit the lens cable to this connector. Contact your Sony representative for more information about the lens you are using.

8 Shoulder pad

You can move the shoulder pad forwards or backwards by loosening the two screws. Do this to ensure the best balance when shooting with the camcorder on your shoulder.

2-3 Audio Functions

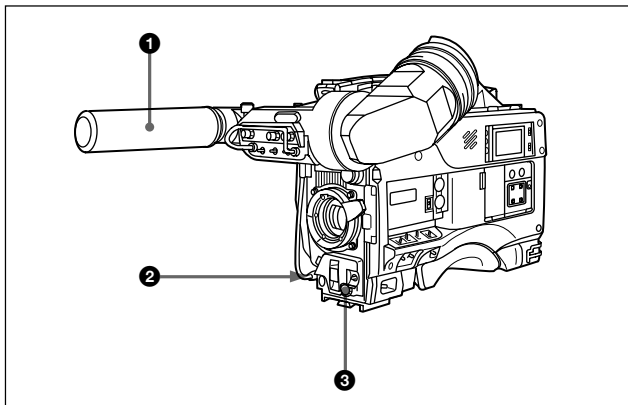

Audio functions (1)

1 Microphone

This is a super-cardioid directional microphone with an external power supply (+48 V) system. You can use it as an interview microphone by connecting it to an extension cable (not supplied).

2 MIC IN (microphone input) connector (XLR type, 3-pin, female)

The supplied microphone connects to this connector. You can connect a microphone other than the supplied one as long as it corresponds to an external power supply system. The connector supplies power (+48 V) to the microphone.

3 MIC/MENU knob

This knob adjusts the audio level of the front microphone. To adjust the front microphone level, set the DISPLAY switch to ON, then push the MENU switch to CANCEL. The audio level indication will appear on the viewfinder screen. Note that you can do this only when the AUDIO SELECT switches are set to MANUAL and the AUDIO IN switches are set to FRONT.

(Continued)

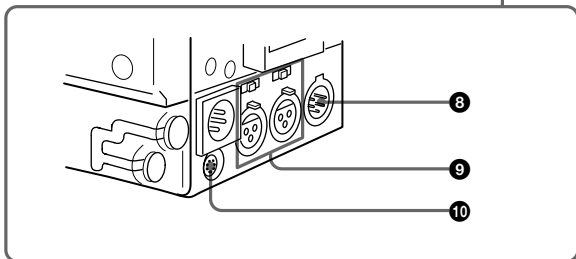
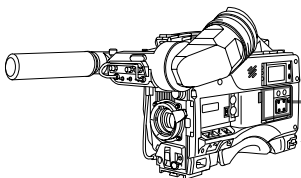
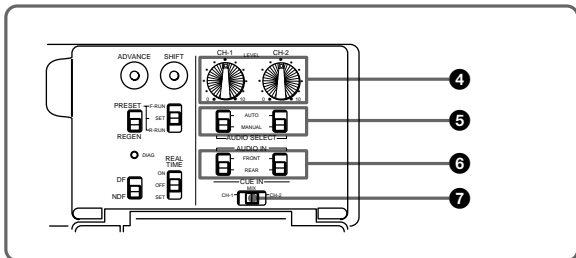

Audio functions (2)

④ LEVEL (CH-1/CH-2) (audio channel 1 and channel 2 recording level) controls

These controls adjust the audio levels of channels 1 and 2 when audio input is from the AUDIO IN CH-1/CH-2 connectors and the AUDIO SELECT switches are set to MANUAL.

⑤ AUDIO SELECT (CH-1/CH-2) (audio channel-1 and channel-2 adjustment method select) switches

These switches select the audio level adjustment method for each of audio channels 1 and 2.

AUTO: Select this setting for automatic adjustment.

MANUAL: Select this setting for manual adjustment.

⑥ AUDIO IN (CH-1/CH-2) (audio input) switches

These switches select the audio input signals to be recorded for audio channels 1 and 2.

FRONT: The input signal source is the microphone connected to the MIC IN connector.

REAR: The input signal source is the audio equipment connected to the AUDIO IN CH-1/CH2 connectors.

You can also record audio signals in audio channels 3 and 4.

You can select the input signals to be recorded for audio channels 3 and 4 by using the AU REC CH 3/4 item on the VTR SETUP page of the MAINTENANCE menu.

The following three input signals are available:

1/2 CH: Records the same input signals connected to the AUDIO CH-1/CH-2 connectors in audio channels 3 and 4..

AUTO: Records inputs signals other than the signals connected to the AUDIO CH-1/CH-2 connectors, that is signals which are not selected using the AUDIO IN switches.

This is effective only when the HDCA-901 camera adaptor is turned off, if connected.

For example: When the CH-1 of the AUDIO IN switch is set to FRONT: The audio signal input to the AUDIO IN CH-1 connector is recorded in channel 3.

(Continued)

When CH-1 of the AUDIO IN switch is set to REAR:

The signal input to the MIC IN connector is recorded in channel 3.

MUTE: Does not record any input signals in channels 3 and 4.

For more information, refer to the Maintenance Manual.

With the HDCA-901 (not supplied) connected to the camcorder, you can record separate sounds in audio channels 3 and 4.

7 CUE IN (cue track input) switch

This switch selects the input signal to be recorded on the cue track.

CH-1: CH-1 input signal

MIX: Mixed input signals of CH-1 and CH-2

CH-2: CH-2 input signal

8 AUDIO OUT (audio output) connector (XLR type, 5-pin, male)

This connector outputs the audio signals recorded to audio channels 1 and 2 or audio channels 3 and 4.

The PB AUDIO CH item on the VTR SETUP page of the MAINTENANCE menu allows you to select the audio signal to be played back.

For more information, refer to the Maintenance Manual.

9 AUDIO IN CH-1/CH-2 (audio channel 1 and channel 2 input) connectors (XLR type, 3-pin, female) and LINE/MIC/+48 V ON (line input/microphone input/external power supply +48 V ON) switches

These are audio input connectors for channels 1 and 2 to which you can connect audio equipment or a microphone.

The LINE/MIC/+48V ON switches select the audio source of the audio input signals connected to each of these connectors.

LINE: Line input audio equipment

MIC: Microphone with an internal power supply

+48V ON: Microphone with an external power supply system

10 DC OUT (DC power output) connector

This connector supplies power for a WRR-810A/860A UHF Portable Tuner (not supplied). Do not connect any equipment other than the UHF portable tuner.

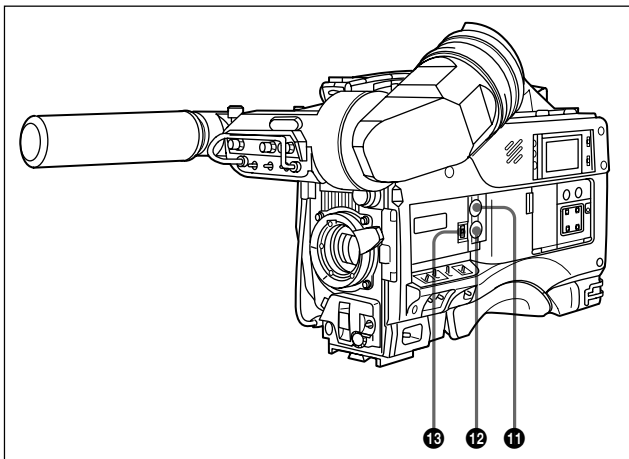

Audio functions (3)

11 ALARM volume control

This control adjusts the speaker or earphone alarm volume. At the minimum position, no sound can be heard.

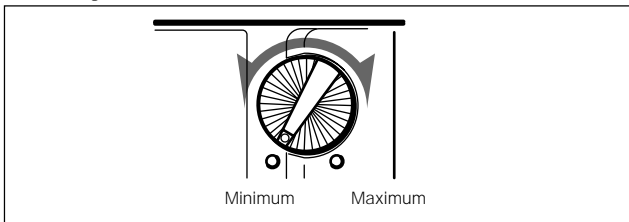

ALARM volume control

(Continued)

The internal volume control can be adjusted so that the alarm is audible even if the ALARL₁ olume control is at the minimum position.

For more information, refer to the Maintenance Manual.

12 MONITOR volume control

This control adjusts the speaker or earphone volume for sounds other than the alarm sound. At the minimum position, no sound can be heard.

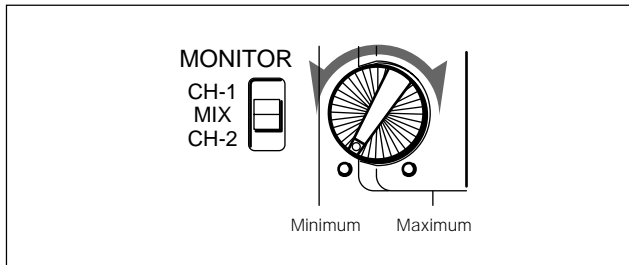

MONITOR volume control

13 MONITOR (audio channel select) switch

This switch selects the audio channel to be output from the speaker or earphone.

CH-1: Channel 1 audio

MIX: Mixed sound of channels 1 and 2

CH-2: Channel 2 audio

During playback, the signals of the audio channels selected from the PB AUDIO CH item on the VTR SETUP page of the MAINTENANCE manual are output.

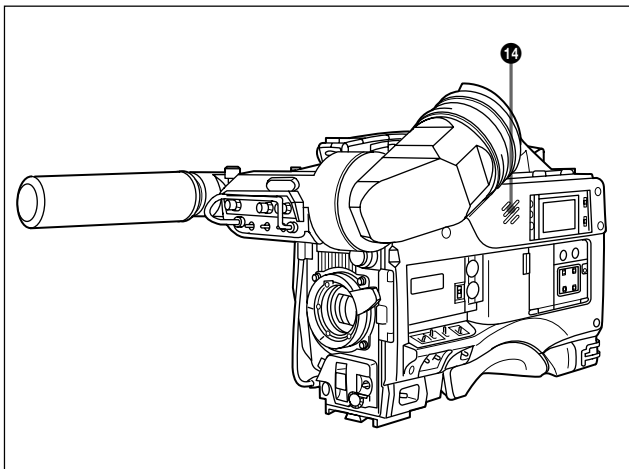

Audio functions (4)

14 Built-in speaker

During recording, the speaker can be used for monitoring the E-E¹⁾ sound, and during playback for monitoring playback sound. The speaker also sounds alarms to reinforce visual warnings.

If an earphone is plugged into the EARPHONE jack, the speaker sound is automatically cut off.

See Section 6-3 “Operation Warnings” (page 6-14) for information about alarms.

1) E-E sound (Electric-to-Electric sound)

The term E-E sound refers to an audio signal that has passed through the amplifier, but has not been recorded on the tape. In other words, you can directly monitor the recording input signal, as opposed to the simultaneous playback (output) signal.

(Continued)

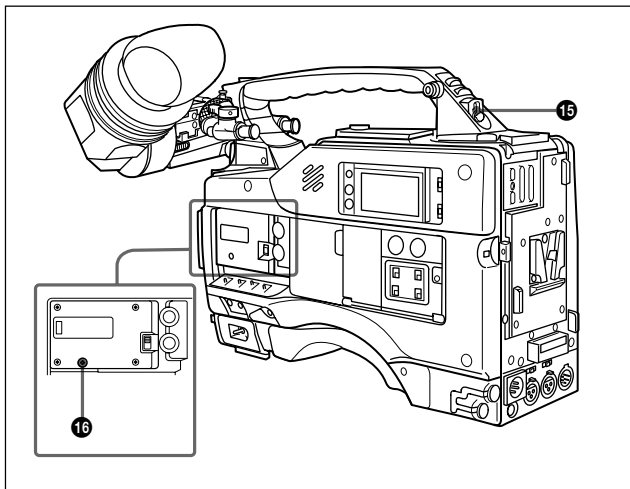

Audio functions (5)

15 EARPHONE jack

You can monitor the E-E sound during recording and playback sound during playback. Plugging an earphone into the jack automatically cuts off the built-in speaker, and you hear the alarms about the camcorder's operation and status through the earphone.

16 Tap for measure hook

This is the hole for the M3 screw (effective screw length: 6mm) located at the position of the flange focal length. You can use this tap to attach the hook for a tape measure to measure the distance between the position of the flange focus and an object. (The effective length of the supplied screw is 6 mm.)

2-4 Shooting and Recording/Playback Functions

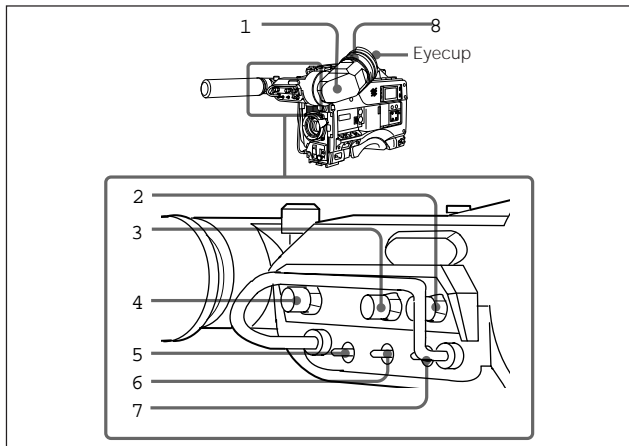

Shooting and recording/playback functions (1)

❶ Viewfinder (When the HDVF-20A (not supplied) is used)

The viewfinder lets you to view the camera image in black and white while shooting the picture and also see the playback picture from the VTR. It also displays various warnings and messages related to the settings or operating conditions of the camcorder, a zebra pattern¹⁾, safety zone marker²⁾, and center marker³⁾.

1) Zebra pattern

The zebra pattern aids in manual iris adjustment by indicating areas of the picture where the video level is approximately 70% and 100% and above.

2) Safety zone marker

The safety zone marker is a rectangle indicating the effective picture area.

For more information, see Section 4-8-3 "Setting the Marker Display" (page 4-55).

3) Center marker

The center marker indicates the center of the picture with a crosshair.

(Continued)

② BRIGHT (brightness) control

This control adjusts the picture brightness on the viewfinder screen. It has no effect on the camera output signal.

③ CONTRAST control

This control adjusts the picture contrast on the viewfinder screen. It has no effect on the camera output signal.

④ PEAKING control

This control adjusts the sharpness of the picture on the viewfinder screen to make focusing easier. It has no effect on the camera output signal.

⑤ DISPLAY/ASPECT (display/aspect control)switch

Use this switch to turn the markers and aspect mask function on or off.

DISPLAY: When MARKER on the MARKER page of the

OPERATION menu is set to ON, pushing this switch to DISPLAY toggles the markers on the viewfinder screen on and off.

ASPECT: When MASK on the MARKER page of the OPERATION menu is set to ON, pushing this switch to the aspect mask function toggles on and off.

⑥ ZEBRA (zebra pattern) switch

This switch controls the zebra pattern on the viewfinder screen.

ON: The zebra pattern is displayed and stays.

OFF: No zebra pattern is displayed.

MOMENT: The zebra pattern is displayed and stays for 5 to 6 seconds.

The zebra pattern is factory set to indicate picture areas where the video level is approximately 70%. The setup menu can be used to specify that areas where the video level is 100% and above are to be displayed at the same time.

For information about how to set the zebra pattern is to be displayed to indicate areas of 100% or more, see Section 4-8-5 “Setting the Viewfinder” (page 4-60).

7 TALLY switch

This switch controls the TALLY indicator, setting its brightness (HIGH or LOW) or turning it off.

HIGH: The TALLY indicator gets brighter.

OFF: The TALLY indicator does not operate.

LOW: The TALLY indicator gets dimmer.

8 Diopter adjustment ring

Use this ring to adjust the viewfinder image for your vision.

(Continued)

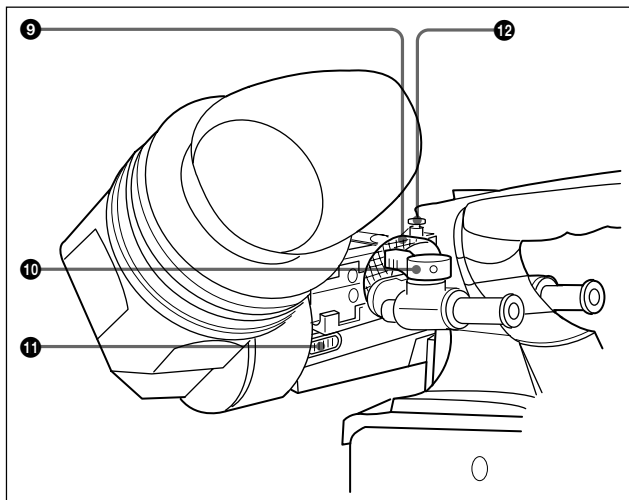

Shooting and recording/playback functions (2)

9 Viewfinder left-right positioning ring

Use this ring to move the viewfinder sideways.

10 Viewfinder front-rear positioning lever

Use this lever to move the viewfinder forward or backward.

11 Cameraman tally indicator

This indicator lights while the camcorder is operating.

Slide the window open when you shoot, keeping your eye away from the viewfinder. This indicator flashes when the battery level is running low or the tape is nearing its end.

12 Viewfinder stopper

Pull up this stopper to detach the viewfinder from the camera.

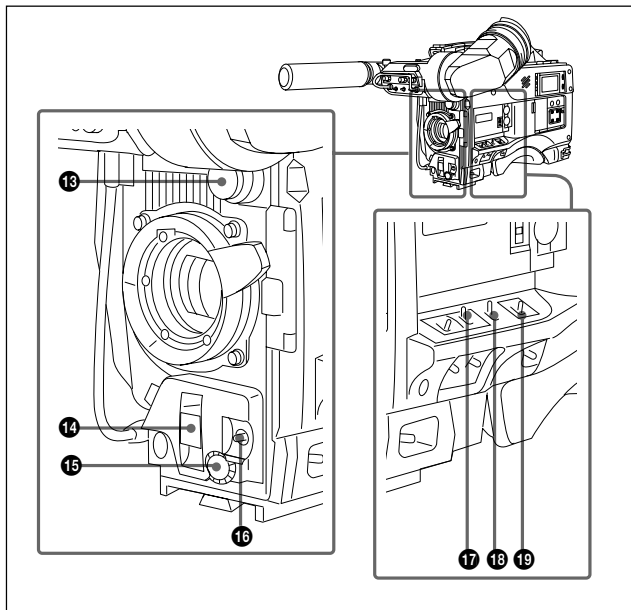

Shooting and recording/playback functions (3)

13 FILTER selector

This selector is a dual knob that selects the most appropriate filter to match the light source illuminating the subject. The outer knob selects the color temperature of the CC (Color Conversion) filter, and the inner knob selects the type of ND (Neutral Density) filter. When this selector is adjusted, the new setting will be indicated on the viewfinder screen for about 3 seconds. The white balance is stored in memory for each CC filter.

(Continued)

The relationships between the selector settings and filter selections as well as examples of filters for different shooting conditions are given below.

FILTER selector (outer) setting and CC filter selection

FILTER selector (outer) setting	CC filter selection
A	5600K
B	3200K
C	4300K
D	6300K

FILTER selector (inner) setting and ND filter selection

FILTER selector (inner) setting	ND filter selection
1	Clear
2	1/4 ND
3	1/16 ND
4	1/64 ND

Examples of shooting conditions and appropriate filters

Shooting condition	CC filter	ND filter
Sunrise and sunset; inside studio	B (3200 K)	1 (clear)
Clear skies	A (5600 K) or D (6300 K)	2 (1/4 ND) or 3 (1/16 ND)
Cloudy or raining	D (6300 K)	1 (clear) or 2 (1/4 ND)
Very bright conditions such as snow, at high altitudes, or at the seashore	A (5600 K) or D (6300 K)	3 (1/16 ND) or 4 (1/64 ND)

14 SHUTTER selector

Set this selector to ON to use the electronic shutter. Set it to SEL to switch the shutter speed or mode setting within the range that has been previously set from the setup menu.

When this selector is adjusted, the new setting will be indicated on the setting change/adjustment progress message display area for about 3 seconds.

For more information about the shutter speed and mode settings, see Section 4-2 “Setting the Electronic Shutter” (page 4-9).

15 MIC/MENU knob

When the DISPLAY switch is set to ON or when the lens is using the automatic iris operation with the DISPLAY switch set to OFF, pressing and turning the MIC/MENU knob sets the iris override (± 1 iris in 1/4 iris steps). The iris override setting returns to 0 when you turn off the camcorder, then on again.

16 AUTO W/B BAL (automatic white/black balance adjustment) switch

This switch activates the white balance and black balance automatic adjustment functions.

WHT: Automatic adjustment of the white balance. If the WHITE BAL switch is set to A or B, the white balance setting is stored in the corresponding memory. The memory can store the white balance setting for each CC filter.

BLK: Automatic adjustment of the black set and black balance.

(Continued)

17 GAIN selector

This selector switches the gain of the video amplifier to match the lighting conditions during shooting. The gains corresponding to the L, M, and H settings are selected from the setup menu before use. The factory settings are L = 0 dB, M = 6 dB, and H = 12 dB.

When this selector is adjusted, the new setting will be indicated on the setting change/adjustment progress message display area of the viewfinder screen for about 3 seconds.

For information about setting the gain values, see Section 4-8-4 “Setting the GAIN Selector Values” (page 4-58).

18 OUTPUT/DCC (output signal/dynamic contrast control) selector

This selector switches the video signal that is output to the VTR, viewfinder, and video monitor, between the color bar signal and the camera output.

BARS: Outputs the color bar signal. The DCC indicator automatically goes off. When the AU REC 1 KHz item on the VTR SETUP page of the MAINTENANCE menu is set to either 0 dB or -20 dB, the 1-kHz audio signal is also output with the color bar signals.

CAM: Outputs the camera signal. It also switches DCC¹⁾ on and off when output from the camera is selected.

1) DCC (Dynamic Contrast Control)

Also called automatic knee. Against a very bright background with the iris opening adjusted to the subject, objects in the background will be lost in the glare. The DCC function will suppress the high intensity and restore much of the lost detail and is particularly effective in the following cases.

- Shooting a subject against a bright sky
- Shooting a subject indoors, against a background through a window
- Any high contrast scenes

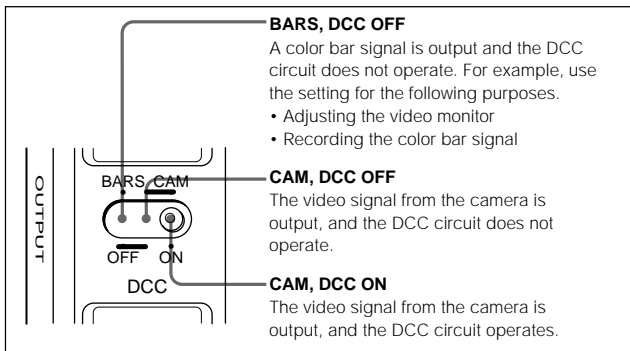

OUTPUT/DCC selector

19 WHITE BAL (white balance memory) switch

This switch determines the source of the white balance settings.

PRST (preset): Adjusts the color temperature corresponding to the position of the FILTER selector (outer knob). Use the PRST setting when you have no time to adjust the white balance.

A or B: When the AUTO W/B BAL switch is pushed to WHT, the white balance is automatically adjusted according to the current position of the FILTER selector (outer knob), and the adjusted value is stored in either memory A or memory B. (There are two memories for each CC filter, so a total of eight adjustments can be stored.) When the FILTER selector (outer knob) is at the same position as it was when this WHITE BAL switch was adjusted, the stored value is called from memory, and the camcorder automatically adjusts itself to that value.

When this switch is adjusted, the new setting will be indicated on the setting change/adjustment progress message display area of the viewfinder screen for about 3 seconds.

(Continued)

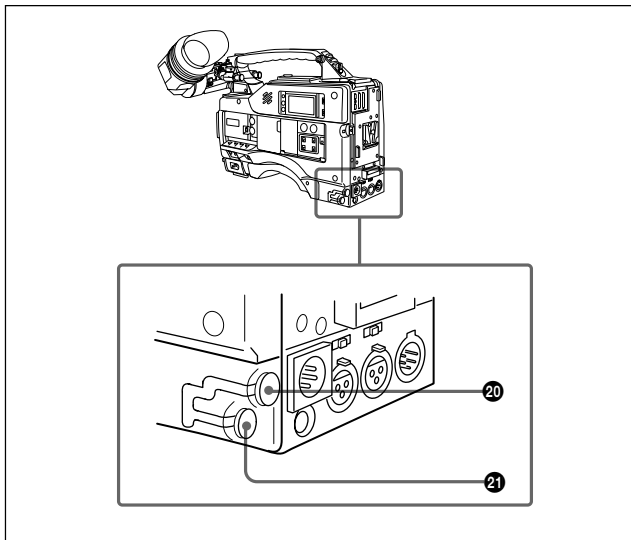

Shooting and recording/playback functions (4)

20 GENLOCK IN (genlock input) connector (BNC type)

This connector inputs an HD reference signal when the camera is to be genlocked or when the time code is to be synchronized with external equipment. Use the MAINTENANCE menu to adjust the genlock H-phase (phase of Horizontal sync signal).

For details, refer to the Maintenance Manual.

Also, assigning the RETURN function to the assignable switch allows you to view the image of the input signal on the viewfinder.

For details, see “4-8-8 Setting the D5600K Mode, Assignable Switches and PB VIDEO” on page 4-66.

21 REMOTE (remote control) connector (8-pin)

Connect the RCP-700 Series or RM-B150 Remote Control Unit (not supplied) with which VTR control is possible. You can also connect and use the MSU-700A/750 Master Setup Unit (not supplied).

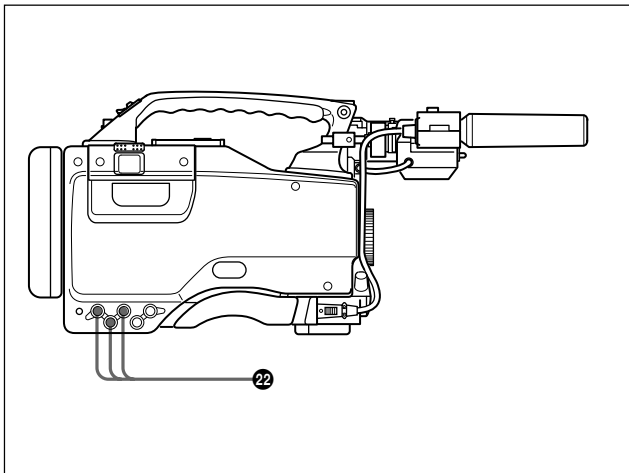

Shooting and recording/playback functions (5)

22 MONITOR OUT connector (BNC type)

This connector outputs the HD video signal (75-ohm terminated, Y/P_B/P_R). To include the text on the viewfinder screen with the output signal, push the DISPLAY switch to MENU while pushing the MENU switch to CANCEL. Text output is cancelled when you turn the camcorder off, then on again.

(Continued)

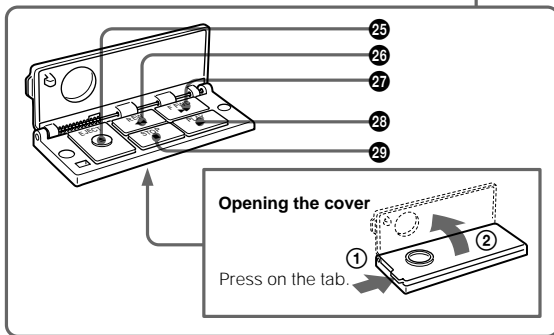
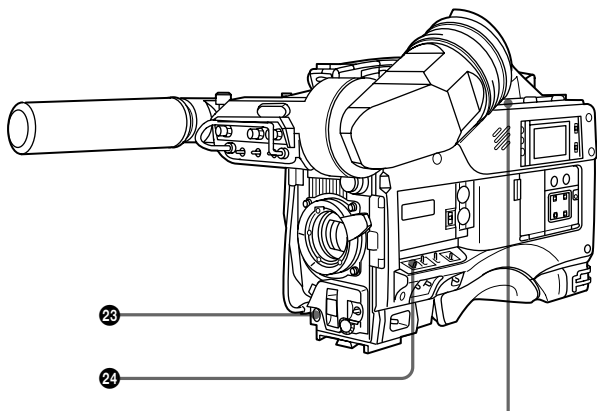

Shooting and recording/playback functions (6)

23 VTR START button

Press this button to start recording. Press it again to stop recording. The effect is exactly the same as that of the VTR button on the lens.

24 VTR SAVE/STBY (VTR power saving/standby) switch

This switch controls the VTR power mode during pauses in recording (REC PAUSE).

SAVE: Power saving mode. When you press the VTR START button, there is a short delay before recording starts, but power consumption is less than in standby mode, and battery life is extended. When the switch is set to SAVE, the VTR SAVE indicator in the viewfinder lights.

STBY: Standby mode. Recording starts as soon as you press the VTR START button. Avoid allowing the camcorder to remain in STBY (standby) mode for a long time.

25 EJECT (cassette eject) button

Press this button to eject or load a cassette.

26 REW (rewind) button and indicator

Press this button to rewind the tape. The indicator lights during rewinding.

(Continued)

27 F FWD (fast forward) button and indicator

Press this button to fast forward the tape. The indicator lights during fast forward.

28 PLAY (playback) button and indicator

Press this button to view the recorded picture in the viewfinder or on the color video monitor. The indicator lights during playback.

The 3 times normal speed search function is provided to make it far quicker to find a desired location of the tape. Press the REW button or F FWD button during playback to view the 3 times normal speed search picture.

29 STOP button

Press this button to stop the tape.

2-5 Setup Menu Operating Section

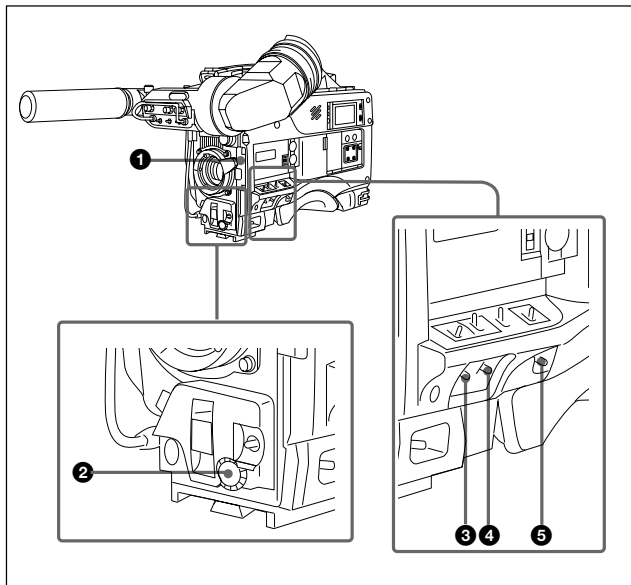

Setup menu operating section

1 Memory Stick compartment

Open the cover of the Memory Stick compartment. Insert the Memory Stick (not supplied) with the notch facing upward and the label facing toward you into the slot.

2 MIC/MENU knob

Use this knob to change the page selection or a setting within the setup menu.

(Continued)

3 MENU switch

Push this switch to CANCEL to erase the menu settings and return to page selection mode or the TOP menu. Push the switch up to display the '!' IND page of the operation menu.

For details on settings of this page, see Section 4-8-2 "Selecting the Items for Which the '!' IND is to Light" (page 4-50).

4 DISPLAY switch

Use this switch to change the display on the viewfinder screen.

ON: A message or character indicating the camcorder's settings or operation status is displayed on the viewfinder screen.

OFF: The display on the viewfinder screen disappears.

MENU: The setup menu is displayed on the viewfinder screen.

5 Assignable switches 1/2

You can assign the desired functions to each of assignable switch on the OTHERS page of the OPERATION menu.

For details, see "4-8-8 Setting the D5600K Mode, Assignable Switches and PB VIDEO" on page 4-66.

2-6 Time Code System

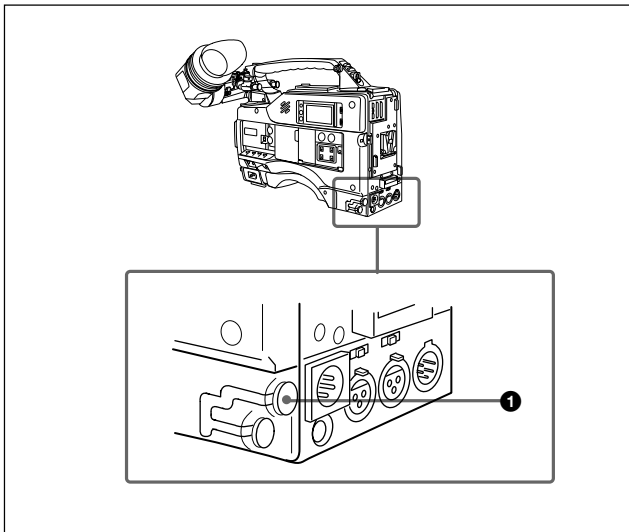

Time code functions (1)

❶ GENLOCK IN (genlock input) connector (BNC type)

This connector inputs an HD reference signal when the camera is to be genlocked or when the time code is to be synchronized with external equipment.

By assigning the RETURN function to the assignable switch(es), you can see the image of the return video signal on the viewfinder.

For details, see “4-8-8 Setting the D5600K Mode, Assignable Switches and PB VIDEO” on page 4-66.

(Continued)

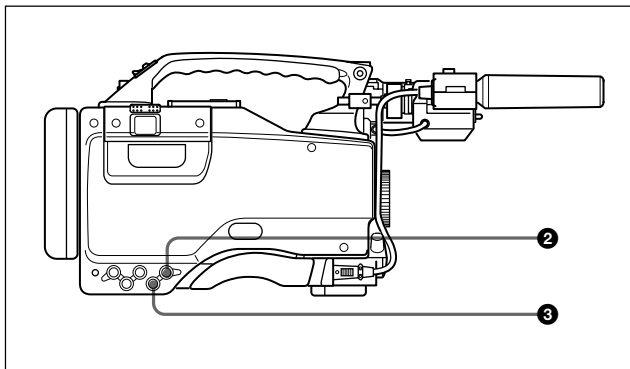

Time code functions (2)

2 TC IN (time code input) connector (BNC type)

To synchronize the time code with an external time code, connect the reference time code input here.

3 TC OUT (time code output) connector (BNC type)

To synchronize the time code of an external VTR with that of the camcorder, connect this connector to the time code input lock connector of the external VTR.

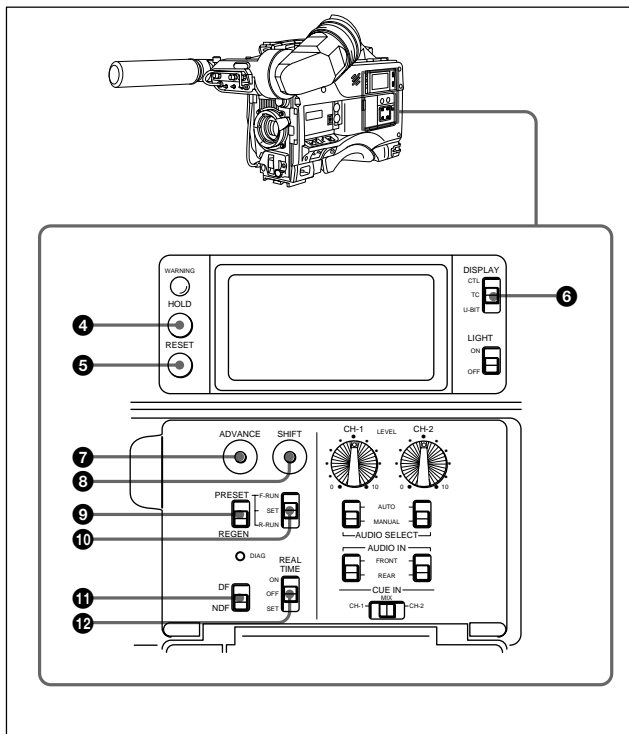

Time code functions (3)

(Continued)

4 HOLD (display hold) button

Pressing this button instantly freezes the time data displayed in the counter display section. (The time code generator continues normal operation.) Pressing this button again releases the hold. One use of this feature is to determine the exact time of a particular shot.

When the HOLD button is activated, the time data is displayed in the following format:

00:00:00:00

See Section 2-8 “Warnings and Indications on the Display Panel” (page 2-38) for more information about the counter display.

5 RESET (counter reset) button

This button resets the time data displayed on the counter display section to “00:00:00:00” and the user bit data to “00000000”.

6 DISPLAY (LCD) switch

Depending on the settings of the F-RUN/SET/R-RUN switch and the REAL TIME switch, this switch selects data to display in the counter display section as follows:

CTL: Control signal

U-BIT: User bits

TC: Time code

For more information, see “Time code displays” (page 2-40).

7 ADVANCE button

For setting the time code, user bits, or real time, each press of this button increments the flashing digit selected by the SHIFT button.

8 SHIFT button

For setting the time code, user bits, or real time, this button selects the digit to be changed. The selected digit flashes.

9 PRESET/REGEN (preset/regeneration) switch

This switch selects whether to set a new time code or to match the existing time code that had been recorded.

PRESET: Starts recording time code values on the tape from the newly set value.

REGEN: Reads the existing time code on the tape and sets the time code starting value accordingly. Thus, even when there is an indefinite break in recording, this setting ensures that time codes on the tape will be continuous. Regardless of the setting of the F-RUN/SET/R-RUN switch, the camcorder operates in R-RUN mode.

For more information, see “Make the time code continuous” on page 4-20.

10 F-RUN/SET/R-RUN (free run/set/recording run) switch

This switch selects the operating mode for the internal time code generator.

F-RUN: The time code generator keeps running, regardless of the operation state of the VTR. Use this position when matching the time code to real time or for synchronizing the time code with an external time code.

SET: Set the switch to this position to set the time code or user bits.

R-RUN: The time code generator runs only while recording. This produces a tape with consecutive time code value, even when shot intermittently.

For more information, see Section 4-4-1 “Setting the User Bits” (page 4-17) and Section 4-4-2 “Setting the Time Code” (page 4-19).

(Continued)

11 DF/NDF (drop frame/non-drop frame) switch

This switch selects whether the time code advances in drop frame mode or non-drop frame mode. This switch is effective only when the format is set to one of 29.97 PsF, 30 PsF, 59.94 I or 60 I in the MULT FORMAT page of the MAINTENANCE menu.

DF: Drop frame mode¹⁾

NDF: Non-drop frame mode²⁾

12 REAL TIME switch

This switch selects whether or not real time is to be recorded as VITC user bit data. It is also used for setting the real time.

ON: Real time is recorded as VITC user bit data.

OFF: Real time is not recorded as VITC user bit data.

SET: Sets the real time.

1) Drop frame mode

To eliminate the discrepancy between the actual time and the time code value generated by the time code generator when the format is set to either 29.97 PsF or 59.94 I in the MULT FORMAT page of the MAINTENANCE menu, drop frame mode drops two frames (frames 00 and 01) from the time code value at the beginning of each minute except every tenth minute.

2) Non-drop frame mode

Non-drop frame mode does not perform the processing of drop frame mode. As a result, when the format is set to either 29.97 PsF or 59.94 I in the MULT FORMAT page of the MAINTENANCE menu, there will be a discrepancy between the actual time and the time code value of about 86 seconds per one day of recording. In case of 30 PsF and 60 I, a discrepancy will not occur.

2-7 Warnings and Indications

The camcorder supplies you visual information and warnings by means of its indicators without you having to use the speaker, earphone or viewfinder.

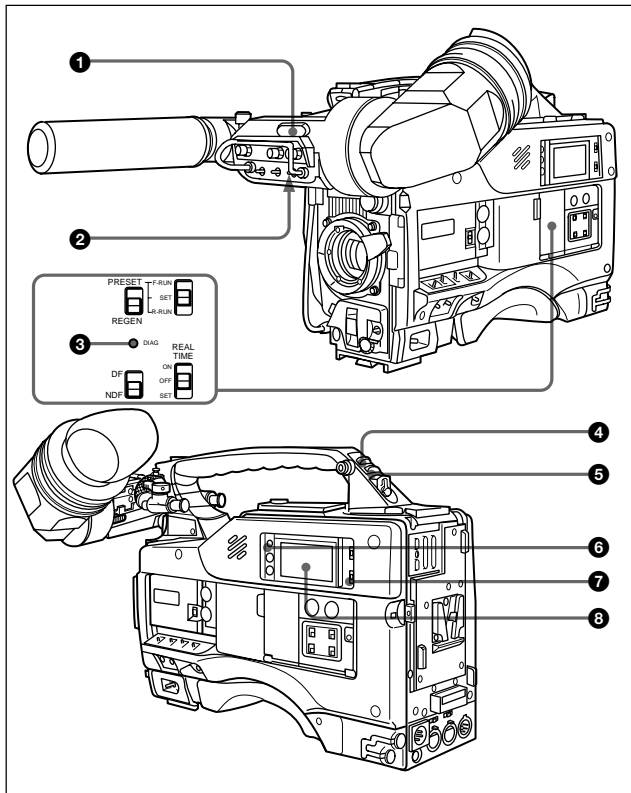

Warning and indication functions

(Continued)

❶ TALLY indicator

Setting the TALLY switch to HIGH or LOW activates this indicator. The indicator lights during recording on the VTR. It also provides the same information as the REC indicator in the viewfinder; it lights up during recording and flashes to indicate a problem. The brightness of this indicator when it is lit can be controlled by the TALLY switch.

❷ TALLY switch

This switch controls the TALLY indicator, setting its brightness (HIGH or LOW) or turning it off.

HIGH: The TALLY indicator gets brighter.

OFF: The TALLY indicator does not operate.

LOW: The TALLY indicator gets dimmer.

❸ DIAG (self-diagnostics) button

Pressing this button when the VTR is stopped switches the camcorder to self-diagnostics mode. In self-diagnostics mode, it is possible to carry out a display panel test, a VTR test, or a camera test and display the test result.

To exit from self-diagnostics mode, press this button once more.

For more information, refer to the Maintenance Manual.

❹ BACK TALLY indicator

This indicator functions exactly the same way as the front tally indicator when the BACK TALLY switch is set to ON.

❺ BACK TALLY switch

This switch enables (ON) or disables (OFF) the operation of the BACK TALLY indicator.

ON: Enables the BACK TALLY indicator operation.

OFF: Disables the BACK TALLY indicator operation.

6 WARNING indicator

This indicator lights up or flashes when there is a fault in the VTR.

See Section 6-3 “Operation Warnings” (page 6-14) for more information about the relationships between the operation of the indicator and the meanings of the indications.

7 LIGHT switch

This switch controls the display panel light.

ON: Turns the panel light on.

OFF: Turns the panel light off.

8 Display panel

VTR error messages, battery status, tape status, audio level, time data, and so forth are displayed on this panel.

For more information, see Section 2-8 “Warnings and Indications on the Display Panel” (page 2-38).

2-8 Warnings and Indications on the Display Panel

Tape status, battery status, and level indicators

2

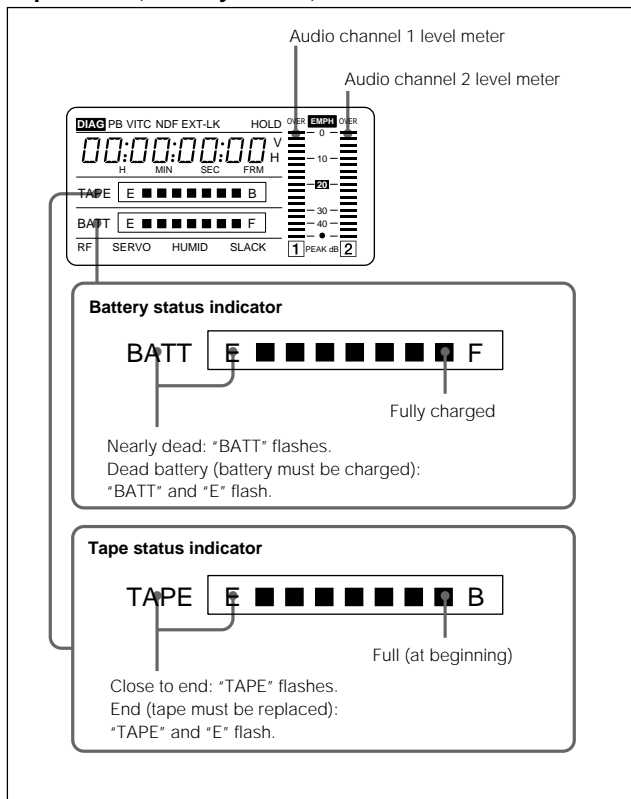

Tape status, battery status, and level indicators

VTR operation status and status indicators

Lights in the self-diagnostic mode (testing display panel, camera, and VTR).

For more information, refer to the Maintenance Manual.

Lights during playback.

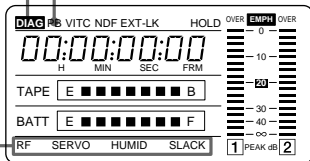

Warning indicators

RF: Lights if the recording heads are clogged.

SERVO: Lights if the servo motor fails.

HUMID: Lights if condensation is on the drum.

SLACK: Lights if the tape is not winding properly.

For more information, see Section 6-3 “Operation Warnings” (page 6-14).

VTR operation and status indicators

Note

If the tape in the VTR becomes slackened, an error code appears automatically on the display section of the display panel.

For more information refer to the Maintenance Manual.

Time code displays

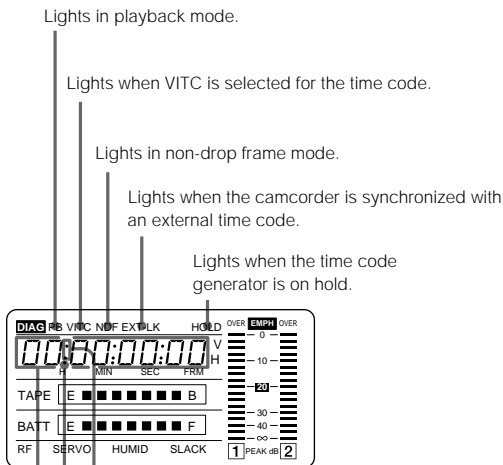

Lights in playback mode.

Lights when VITC is selected for the time code.

Lights in non-drop frame mode.

Lights when the camcorder is synchronized with an external time code.

Lights when the time code generator is on hold.

Lights when the time code, CTL, or real time is displayed.

Lights in the following way when the HOLD button is pressed.

00:00:00:00

Time counter display: Shows the time code, CTL, user bits, and real time.

The table on the next page lists the details of the displayed items and switch settings.

Time code displays

Relationships between the REAL TIME, F-RUN/SET/R-RUN, and DISPLAY switch settings and the time counter displays

The time counter display is determined first by the REAL TIME switch setting, then by the F-RUN/SET/R-RUN switch setting, and finally by the DISPLAY switch setting.

Switch settings related to time code and displayed information

REAL TIME switch position	F-RUN/SET/R-RUN switch position	DISPLAY switch position	Displayed information
ON or OFF	SET	TC or CTL	Time code
		U-BIT	User bits
	F-RUN or R-RUN	CTL	CTL
		TC	Time code
		U-BIT	User bits
		Any position	Acrual time
SET	Any position	Any position	Acrual time

2-9 Indicators on the Viewfinder (HDVF-20A (not supplied))

2

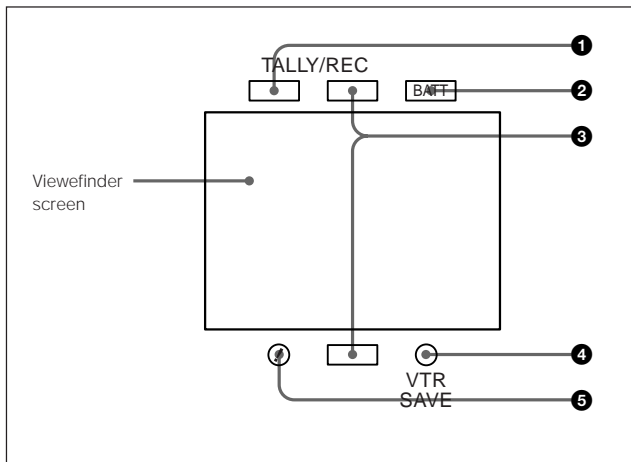

Indicators on the Viewfinder

❶ TALLY indicator

Not used in the camcorder.

❷ BATT indicator

Starts flashing when the battery voltage supplied to the camcorder drops below the minimum level, and stays lit when the battery is exhausted. To prevent interruption during operation, replace the battery as soon as this indicator starts flashing.

The level at which the indicator starts flashing can be set on the BATT ALARM page of the MAINTENANCE menu. Also, you can confirm the set alarm voltage on the BATT ALARM page of the OPERATION menu.

For more information, see “4-8-7 Setting the Battery” on page 4-64.

3 TALLY/REC indicator (red)

Depending on the status, this indicator will light up or flash.

When lit: The image shot by the camera is being recorded.

Note

This indicator will be brighter than usual for a moment after it is first lit. This is only a warning, and not a malfunction.

When flashing: The servo system of the VTR section is unlocked and so on.

For more information on the status by which the TALLY/REC indicator will light or flash, see “6-3 Operation Warnings” on page 6-14.

4 VTR SAVE indicator

Lights up when the VTR section is set to power save mode by setting the VTR SAVE/STBY switch to SAVE.

5 ! (warning) indicator

Lights up when the settings of the camcorder are changed from the ones set on the “IND” page of the OPERATION menu.

For details, see “4-8-2 Selecting the Items for Which the ‘!’ IND is to Light” on page 4-50.

3-1 About Cassettes

This section describes the procedure for loading and unloading a cassette.

See "Specifications VTR Section" (page A-3) for information about the cassettes you can use in the camcorder.

3-1-1 Loading and Unloading a Cassette

Loading a cassette

- 1 Turn on the POWER switch.

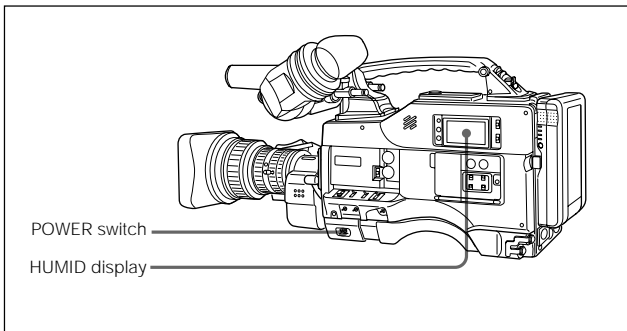

Note

If the interior of the VTR section is damp, the HUMID indicator will light. If this happens, wait until the indicator goes off before going on to step 2.

(Continued)

- 2** Press the EJECT button.
The cassette lid will open.

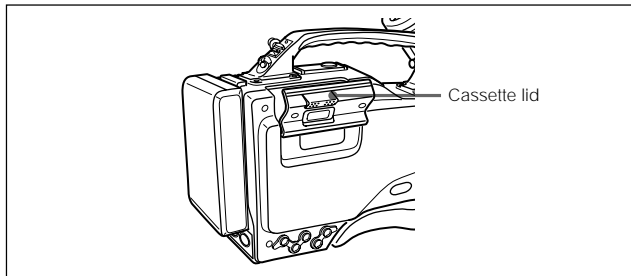

- 3** Check that there is no slack in the tape. Then slide in the cassette until it clicks into position and close the cassette lid completely by pressing near the engraved "PUSH".

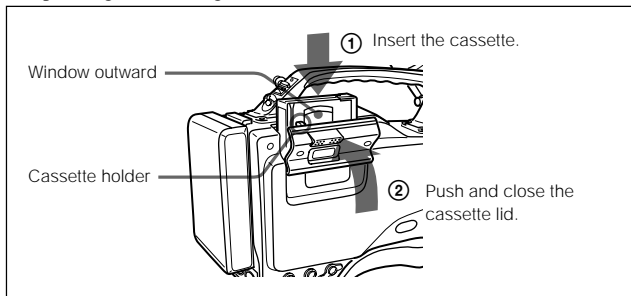

Notes

- To insert the tape correctly, make sure the tape in the cassette is facing up towards you before you try to close the cassette lid.
- When inserting the tape, be careful that you don't hit the tape against the tape holder.

Checking the tape for slack

Pressing in the reels lightly, turn them gently with your fingers in the directions shown below. If the reels will not move, there is no slack.

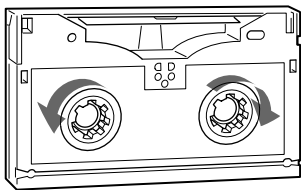

Checking the tape for slack

Unloading a cassette

With the power supply on, press the EJECT button to open the cassette lid. Then take out the cassette. If you are not going to insert another cassette, close the cassette lid.

It is possible to take out the cassette and close the cassette lid unless the battery voltage drops below about 10.5 V. Do not repeat this unloading operation.

Unloading a cassette manually

If the battery voltage drops below about 10.5 V, take out the cassette manually as illustrated below.

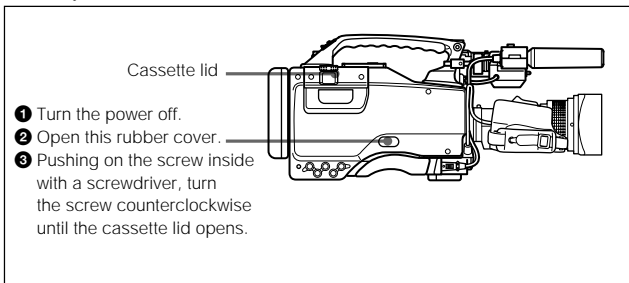

Unloading a cassette manually

You need not return the screw to its original position after taking out the cassette. Although the cassette lid is not locked, turning on the power makes the cassette lid operable again.

3-1-2 Preventing Accidental Erasure

The following procedure prevents cassettes from being recorded inadvertently.

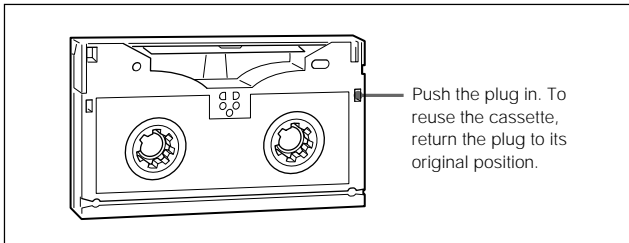

Preventing accidental erasure

3-2 Recording

3-2-1 Basic Procedure

This section describes the basic procedure for shooting and recording. Before a shooting session, ensure that the camcorder is functioning properly.

For more information, see Section 6-1 “Testing the Camcorder Before Shooting” (page 6-1).

3

Turning on the camcorder and loading a cassette

Follow the procedure below.

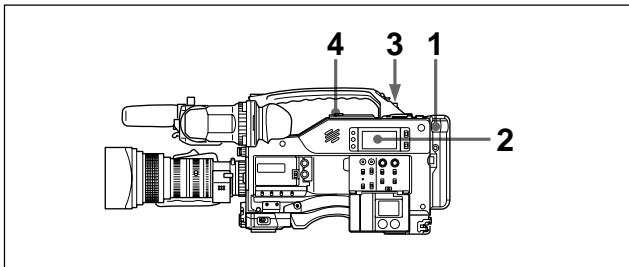

Basic procedure for shooting : from power supply to cassette loading

- 1** Attach a fully charged battery pack.
For details, see “5-1 Power Supply” on page 5-1.
- 2** Set the POWER switch to ON. Check that the HUMID indicator does not appear and that the BATT indicator shows at least five segments.
 - If HUMID indicator appears, wait until it disappears.
 - If the BATT indicator does not show at least five segments, replace the battery pack with a fully charged one.

(Continued)

3 Check that there are no obstructions near the cassette lid. Then press the EJECT button to open the cassette lid.

4 After checking the points below, load the cassette and close the cassette lid.

- The cassette is not write-protected.
- There is no slack in the tape.

3

Basic procedure for shooting: from adjusting the black balance and white balance to stopping recording

After turning on the power and loading a cassette, set the switches and selectors as shown below and begin operation.

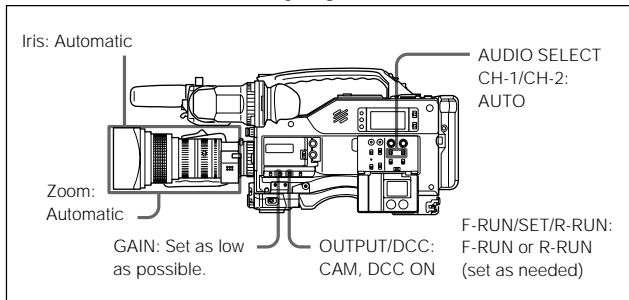

Switch and selector settings before shooting

Shooting

Follow the procedure below.

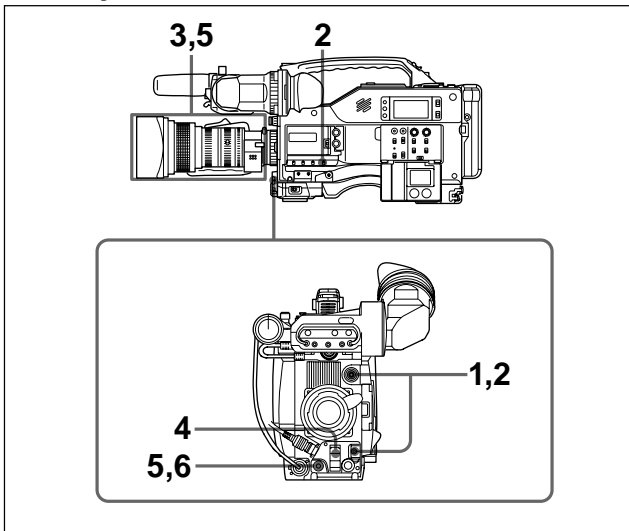

Basic procedure for shooting: from adjusting the black balance and white balance to stopping recording

- 1** Push the AUTO W/B BAL switch to BLK to adjust the black balance.
For detailed information on how to adjust the black balance, see “4-1-1 Adjusting the Black Balance” on page 4-2.
- 2** Select the CC filter and ND filter to match the lighting conditions, and adjust the white balance.

(Continued)

When the black balance and white balance settings are already in memory:

Set the WHITE BAL switch to A or B.

When the white balance setting is not in memory and you do not have enough time to adjust the white balance:

Set the WHITE BAL switch to the PRST position. The white balance is automatically set to 3200 K when the FILTER selector is set to B, to 4300 K when the FILTER selector is set to C, and to 6300 K when the FILTER selector is set to D.

For more information, see Section 4-1-2 “Adjusting the White Balance” (page 4-5).

- 3** Aim the camera at the subject and adjust the focus and zoom.
- 4** If necessary, set the electronic shutter for an appropriate mode and speed.
For more information, see Section 4-2 “Setting the Electronic Shutter” (page 4-9).
- 5** To start recording, press the VTR START button or the VTR button on the lens.
Or if the VTR S/S function is assigned to either of the assignable switches 1/2, these assignable switches function as VTR START/STOP buttons.
For details, see “4-8-8 Setting the D5600K Mode, Assignable Switches and PB VIDEO” on page 4-66.
During recording, the REC indicator in the viewfinder goes on. Perform zooming and focus control, if necessary.
- 6** To stop recording, press the VTR START button or the VTR button on the lens again.
The REC indicator goes off.

Cassette control buttons

During recording, the cassette control buttons (EJECT, REW, F FWD, PLAY, STOP) have no effect.

3-2-2 Continuous Recording

If the camcorder is in the recording pause mode, simply pressing the VTR START button on the camcorder or the VTR button on the lens continues recording at exactly the next frame.

In other cases, you first need to position the tape at an appropriate point.

When the camcorder is in the recording pause mode

Pressing the VTR START button on the camcorder or the VTR button on the lens positions the tape at the appropriate point automatically.

However, the time taken before recording starts depends on the setting of the VTR SAVE/STBY switch.

- If the VTR SAVE/STBY switch is in the SAVE position, it takes about 4 seconds before recording starts.
- If the VTR SAVE/STBY switch is in the STBY position, recording starts immediately. However, just after the switch position is changed from SAVE to STBY, it takes about 4 seconds before recording starts.

If you turn off the power during a recording pause

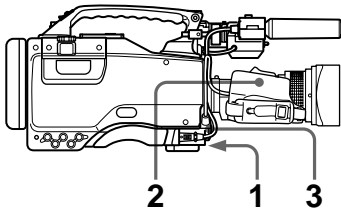

Continuous recording after turning off the power during a recording pause

- 1** Turn on the power again.
- 2** Press the RET button on the lens.

The camcorder positions the tape at the appropriate point. Note, however, that this function works only for continuously recorded material or consecutively joined segments totaling at least 4 seconds in length.

- 3** Press the VTR START button on the camcorder or the VTR button on the lens to start recording.

Continuous recording in other cases

After rewinding or fast forward, after removing the cassette, or on a tape that has been partially recorded, you can obtain a continuous recording by following the procedure below.

Note

If the tape is recorded with a format which is different from the format for the camcorder selected on the MULT FORMAT page of the MAINTENANCE menu, recording may not continue smoothly. Noise and so on occurs at the point where recordings are continued.

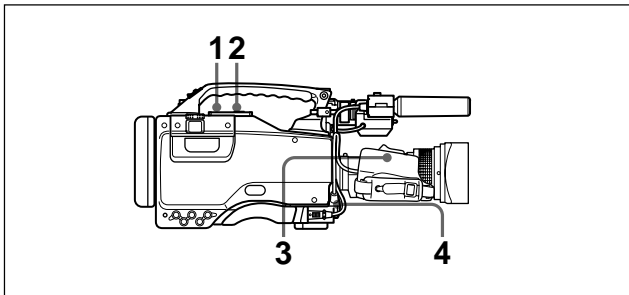

Continuous recording after rewinding or fast forward, after removing the cassette, or on a tape that has been partly recorded

- 1 Looking in the viewfinder, press the PLAY button to start playback.
- 2 Press the STOP button at the desired point to begin recording. To continue from the end of recording already on the tape, press the STOP button immediately after the end of the previous recording (within 0.5 seconds).

(Continued)

-
- 3** Press the RET button.

The tape will rewind and will be positioned at the desired point to continue recording.

- 3** **4** Press the VTR START button on the camcorder or the VTR button on the lens to start recording.

3-3 Checking the Recording — Playback

By pressing the PLAY button, you can review any length of recording in the viewfinder in black and white. There are three other ways to review the recording.

- **Recording review:** You can view the last 3 seconds of the recording in the viewfinder in black and white.
- **Color playback:** You can see the recording in color on a color video monitor without the need for any external adaptor.
- **Color playback/camera picture:** The menu allows you to change the settings so that you can see images as seen by the camera on the viewfinder or on the HD monitor connected to the MONITOR OUT connector even during playback. In this case, if you attach an HDCA-901 Camera Adaptor, you can see the recorded images on an HD monitor connected to the HDCA-901.

Note

To use this function, you have to choose the settings for the output signal.

For detailed information, see "4-8-8 Setting the D5600K Mode, Assignable Switches and PB VIDEO" on page 4-66.

You may also view the picture by pressing the PLAY + REW button or PLAY + F FWD button during searching by rewinding or fast forwarding.

See Section 2-3 "Audio Functions" (page 2-5) for information about the switches and controls used to select the audio output signal and to adjust the audio level.

Note

When a tape recorded in a different format is played back, a warning message appears in the display window during playback.

Example: When the format of the recorded tape is 59.94I and the format of the camcorder is set to 23.98 PsF, the message "59 - - 23" appears.

3-3-1 Checking the Last Three Seconds of the Recording — Recording Review

If you press the RET button on the lens while recording is paused, the last three seconds of the tape is automatically rewound, and that segment is played back on the viewfinder screen. Use this function to check whether recording went smoothly. If you hold the RET button down longer, at most 10 seconds of the tape is rewound and played back. After playback, the camcorder is ready to start recording again.

By assigning the LENS RET function to the assignable switch(es) using the OPERATION menu, you can use the assignable switch(es) in the same way as the RET button on the lens.

For details, see “4-8-8 Setting the D5600K Mode, Assignable Switches and PB VIDEO” on page 4-66.

Note

The recording review functions only works if the recording you have made is at least 3 seconds long.

3-3-2 Checking the Recording on the Color Video Monitor — Playback in Color

Connect a color video monitor to the MONITOR OUT connector of the camcorder and press the PLAY button.

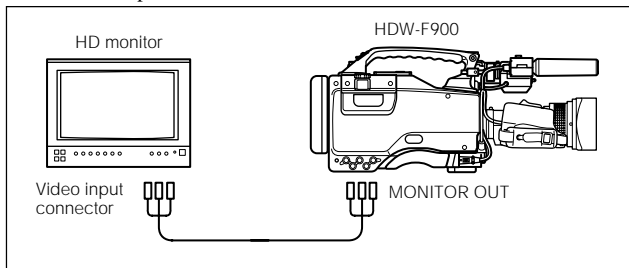

Color playback

3-3-3 Checking the Camera Picture on the Viewfinder and/or Color Video Monitor

Usually, during playback of a tape, if you press the PLAY button, the image sent to the viewfinder or the MONITOR connector is switched back and forth between the camera image and to recorded image.

However, the PB VIDEO item on the OTHERS page allows you to change the setting so that the image seen through the camera is sent to the viewfinder and the MONITOR OUT connector even while you are playing back a video tape.

The HD SDI output from the HDCA-901 Camera Adaptor (not supplied) is switched to that of the recorded image during the playback regardless of the PB VIDEO setting.

For detailed information, see "4-8-8 Setting the D5600K Mode, Assignable Switches and PB VIDEO" on page 4-66.

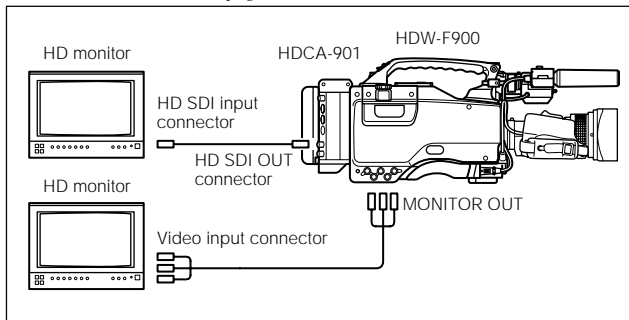

3-4 Tele-File

The VTR section is compatible with the Tele-File memory label system. This system allows you to record the recording start timecode and shot markers onto the MLB-1M 100 memory label (not supplied).

Follow the procedure below to record the starting timecode and shot markers.

3

- 1 Insert the cassette onto which the MLB-1M-100 memory label has been attached.
- 2 Press the VTR START button or the VTR button on the lens.

At the instant the recording starts, the timecode of the recording start is recorded on the memory label.

- 3 While shooting, press the RET button on the lens to create the shot marker.

The timecode valid when you press the RET button is recorded on the label as the shot marker.

To confirm that the RET button is pressed

Set the DISPLAY switch to ON.

Whenever you press the RET button, the circle lights up on the right side of the REC lamp in the viewfinder.

Note

If you set the POWER switch to OFF within 1 second after a recording pause, the recorded data is not guaranteed.

To clear recorded data

For detailed information on how to clear data, see the maintenance manual.

1) Shot marker: Time code to be used as the editing point when editing.

4-1 Adjusting the Black Balance and the White Balance

To always obtain excellent image quality when using this camcorder, conditions may require that both the black balance and the white balance be adjusted.

Black balance adjustment

The black balance will require adjustment in the following cases.

- When the camcorder is first used
- When the camcorder has not been used for a long time
- When the camcorder is used under conditions in which the surrounding temperature has changed greatly
- When the GAIN selector values have been changed by using the setup menu

It is not usually necessary to adjust the black balance when using the camcorder after it has been briefly off.

White balance adjustment

Always readjust the white balance when the lighting conditions change.

Viewfinder screen displays

When the black balance, white balance adjustment or white spots correction is started, messages that report on the progress and results are displayed on the viewfinder screen.

Note

Black balance and white balance adjustment values that are automatically set by the camcorder and the various settings are stored in the camcorder memory and retained even when the power is turned off.

4-1-1 Adjusting the Black Balance

In automatic black balance mode, adjustments are performed in the following order: clamp level, black set, and black balance. Manual black balance adjustment can be selected from the setup menu.

Follow the procedure below to adjust the black balance.

- 1 Set the switches as shown in the figure below.

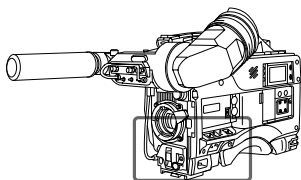

GAIN switch:
Set as low as
possible.

OUTPUT/DCC
switch: CAM

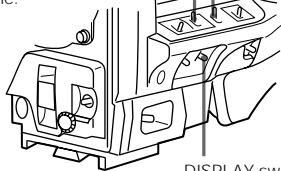

DISPLAY switch: OFF

2 Push the AUTO W/B BAL switch to BLK and release the switch.

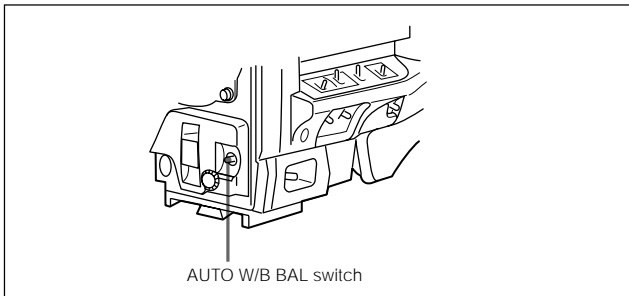

The switch returns to the center position, and the adjustment is completed.

During adjustment, the following message is displayed on the viewfinder screen.

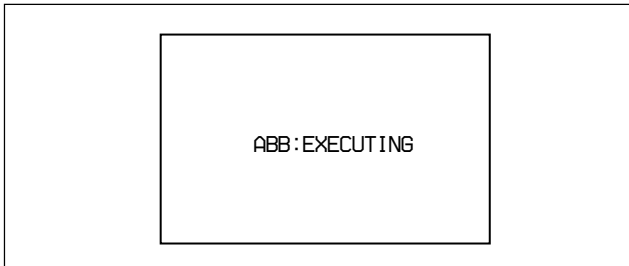

The black balance adjustment ends in a few seconds with the message “ABB:OK” and the adjustment setting is automatically stored in memory.

(Continued)

Notes

- During the black balance adjustment, the iris is automatically closed.
- During the black balance adjustment, the gain selection circuit is automatically activated so you may see flickering on the viewfinder screen, but this is not a fault.

If automatic black balance adjustment cannot be made

If the black balance adjustment cannot be completed normally, the error message “ABB:NG” will appear for about 3 seconds on the viewfinder screen. If this error message is displayed, retry the black balance adjustment. If the error message occurs again, an internal check is necessary.

Refer to the Maintenance Manual for information about this internal check.

Black balance memory

Values stored in memory are retained even when the camcorder power is turned off.

4-1-2 Adjusting the White Balance

Follow the procedure below to automatically adjust the white balance.

- 1 Adjust the switches as shown in the figure below.

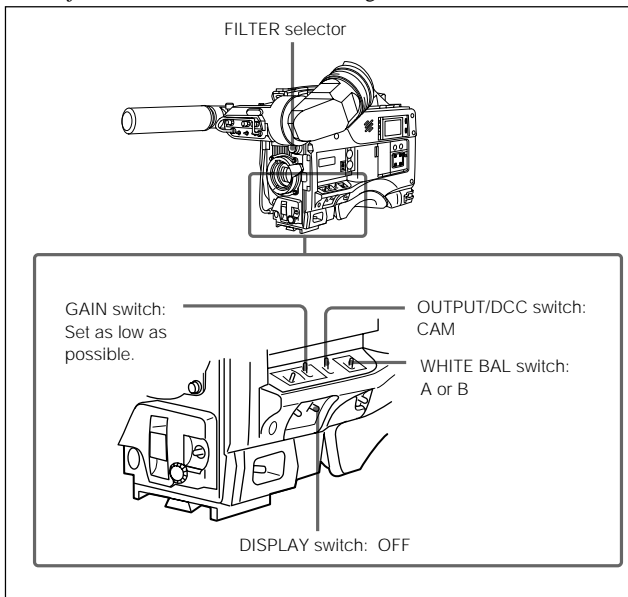

If the setting on the GAIN selector or WHITE BAL switch is changed, a message reporting the set position appears for about 3 seconds in the setting change and adjustment progress message display area of the viewfinder screen.

(Continued)

2 Adjust the FILTER selector to suit the lighting conditions.

ND filter		CC filter	
1	Clear	A	5600K
2	1/4 ND	B	3200K
3	1/16 ND	C	4300K
4	1/64 ND	D	6300K

4

If the setting of the FILTER selector is changed, a message reporting the setting appears for about 3 seconds in the setting change and adjustment progress message display area of the viewfinder screen.

3 Place a white test card under the same lighting conditions as the subject to be shot and zoom up to it. Alternately, any white object such as a cloth or a wall could be used.

The absolute minimum white area is as follows:

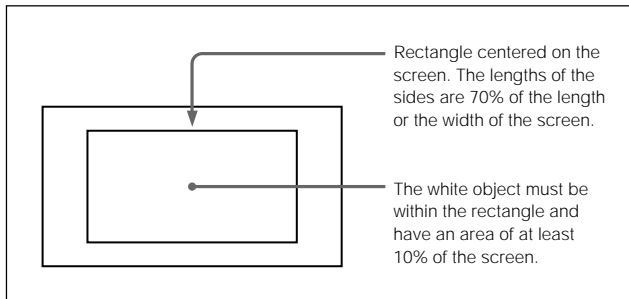

Note

Make sure there are not bright spots in the rectangle.

- 4 Adjust the lens iris.
If the lens is manually adjusted, adjust it as appropriate.
If the lens has an automatic iris, set the automatic/manual switch on the lens to automatic.
- 5 Push the AUTO W/B BAL switch to WHT and release the switch.

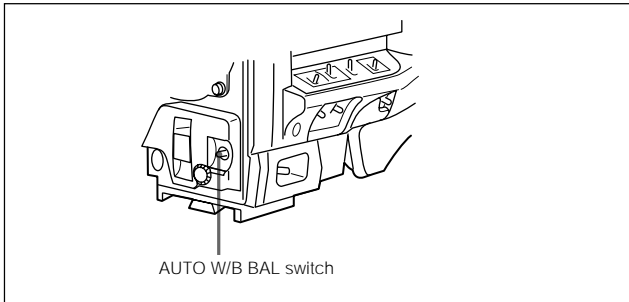
4

The switch returns to the center position, and the adjustment is completed.

During adjustment, the message “AWB:EXECUTING: is displayed in the lower left portion of the viewfinder screen.

The white balance adjustment ends in a second with the message “AWB:OK”, and the adjustment setting is automatically stored in the memory (A or B) that was selected in step 1.

(Continued)

Note

If the camera has a zoom lens with an automatic iris, the iris may hunt¹⁾ during the adjustment. To prevent this, adjust the iris gain knob (marked with IG, IS, or S) on the lens.

For more information, refer to the lens operation manual.

If the automatic white balance adjustment cannot be made

4

If the white balance adjustment cannot be completed normally, the error message “AWB:NG” will appear for about 3 seconds on the viewfinder screen.

If this error message is displayed, retry the white balance adjustment. If the error message occurs again, an internal check is necessary.

Refer to the Maintenance Manual for information about this internal check.

If you have no time to adjust the white balance

Set the WHITE BAL switch to PRST. The white level is reset to the value saved in the reference file (factory setting: 3200K). The white balance is automatically set according to the FILTER selector (outer knob) position.

White balance memory

Values stored in memory are retained even when the camcorder power is turned off.

1) Hunting

Repeated brightening and darkening of an image, resulting from repeated response to automatic iris control.

4-2 Setting the Electronic Shutter

This section describes the shutter modes that can be used with the electronic shutter of the camcorder, and describes the procedure for selecting the shutter speed and mode.

4-2-1 Shutter Modes

The shutter modes that can be used with the electronic shutter and the shutter speeds that can be selected are listed below.

Selectable shutter modes and speeds		
Mode	Shutter speed	Application
Standard	60I (59.94I): 1/100, 1/125, 1/250, 1/500, 1/1000, 1/2000 (sec.) 50I: 1/60, 1/125, 1/250, 1/500, 1/1000, 1/2000 (sec.) 30PsF (29.97PsF): 1/40, 1/50, 1/60, 1/120, 1/125, 1/250, 1/500, 1/1000 (sec.) 25PsF: 1/33, 1/50, 1/60, 1/100, 1/125, 1/250, 1/500, 1/1000 (sec.) 24PsF (23.98PsF): 1/32, 1/48, 1/50, 1/60, 1/96, 1/125, 1/250, 1/500, 1/1000 (sec.)	For shooting fast-moving subjects with little blurring.
ECS (Extended Clear Scan)	60I (59.94I): 30.0 to 4300 Hz 50I: 25.0 to 4700 Hz 30PsF (29.97PsF): 30.0 to 2700 Hz 25PsF: 25.0 to 2300 Hz 24PsF (23.98PsF): 24.0 to 2200 Hz	For obtaining images with no horizontal bands of noise when shooting subjects such as monitor screens.
S-EVS (Enhanced Vertical definition System)	1/60 sec. (automatic setting) 0 to 100 %	Improved vertical resolution. However, the sensitivity and dynamic range are reduced.

(Continued)

Notes

- Whatever the operating mode of the electronic shutter, the iris opens wider as the shutter speed increases, thus reducing the depth of field.
- Under artificial light, particularly fluorescent or mercury lamps, the light intensity may appear to be constant, but the strengths of each of the R, G, and B colors are actually changing in synchronization with the frequency of the power supply ("flicker"). Using an electronic shutter under such lighting could make the flicker even worse. Color flicker is particularly likely to happen when the power supply is 60 Hz. However, if the power supply is 50 Hz, setting the shutter speed to 1/100 can reduce this flicker.

4-2-2 Selecting the Shutter Mode and Speed

Setting the shutter mode (standard-mode/ECS mode) and standard-mode shutter speed

Use the SHUTTER selector to select a shutter mode or a standard-mode shutter speed.

Once the shutter speed is selected, it is retained even when the camcorder power is turned off.

- 1** Follow the procedure described in "Selecting the Display Items" (page 4-39) to set SHUTT to ON from the VF DISPLAY page of the OPERATION menu.
- 2** Push the SHUTTER selector from ON to SEL.

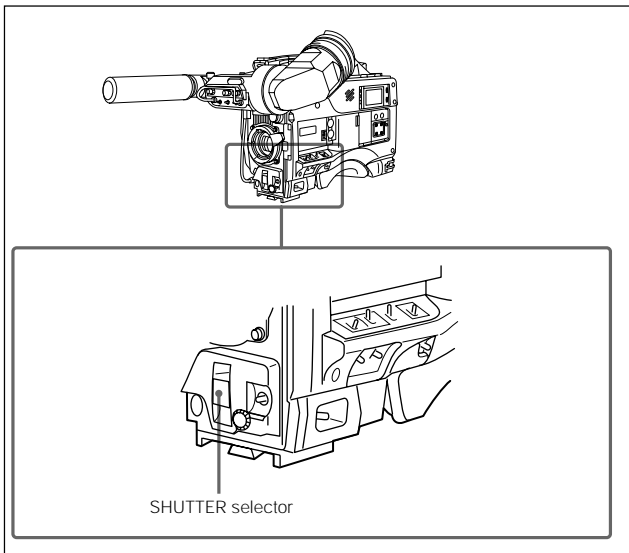

The current shutter setting appears for about 3 seconds in the setting change and adjustment progress message display area of the viewfinder screen. (e.g., :SS:1/250)

- 3** Before the message from step **2** disappears, push the SHUTTER selector to SEL again and repeat until the desired mode or speed appears.
Pushing the SHUTTER selector to SEL repeatedly allows you to cycle through all of the pre-selected settings of mode and speed.

(Continued)

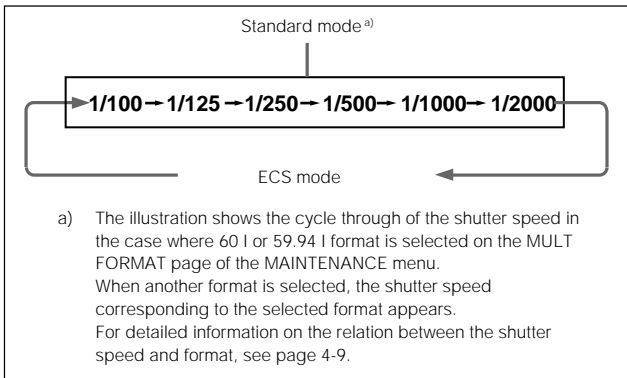

When selecting ECS mode in step 3

You can change the speed by rotating the MIC/MENU knob on the front of the camcorder.

To select S-EVS mode

You can select S-EVS mode and change the speed with the PAINT menu.

For more information, see Section 4-9 “Paint Menu” (page 4-72).

4-3 Adjusting the Audio Level

If you set the AUDIO SELECT CH-1/CH-2 switches to AUTO, the input levels for the corresponding channels are adjusted automatically.

Follow the procedure below to manually adjust the input levels for both audio channels.

Manually adjusting the audio levels of the audio input from the AUDIO IN CH-1/CH-2 connectors

Follow the procedure described below to adjust the audio levels of the audio input from the AUDIO IN CH-1/CH-2 connectors, which is entered to channels 1 and 2.

4

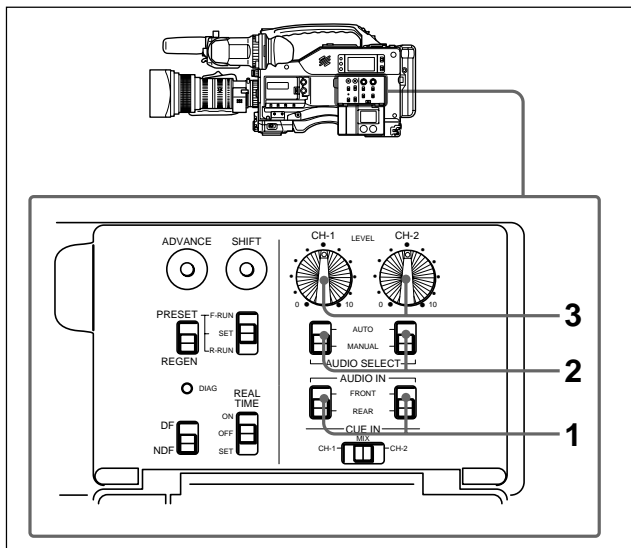

Manual adjustment of the audio levels of AUDIO IN CH-1/CH-2

(Continued)

- 1 Set the AUDIO IN switch which corresponds to the channels to be adjusted among input signals connected to AUDIO IN CH1/CH2 connectors to REAR.

To adjust channels 1 and 2, set the both AUDIO IN switches to REAR.

- 2 Set the AUDIO SELECT switches corresponding to the channel selected in step 1 to MANUAL.

4

- 3 Adjust the LEVEL controls corresponding to the channel selected in step 1 so that at the maximum sound level, the level meter indicates -20 dB. The second bar from the top may turn on occasionally, but do not allow the top bar to go on. If it goes on, the audio level is too high.

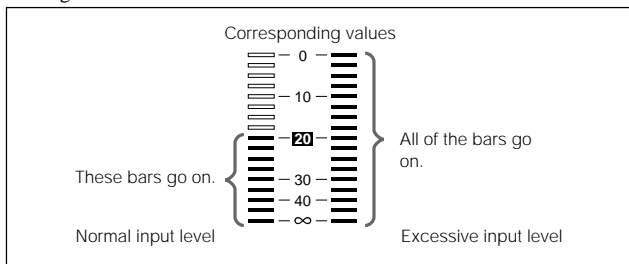

Manually adjusting the audio level of the front microphone

You can adjust the audio level input from the front microphone for channels 1 and 2 by using the MIC/MENU knob on the front of the camcorder.

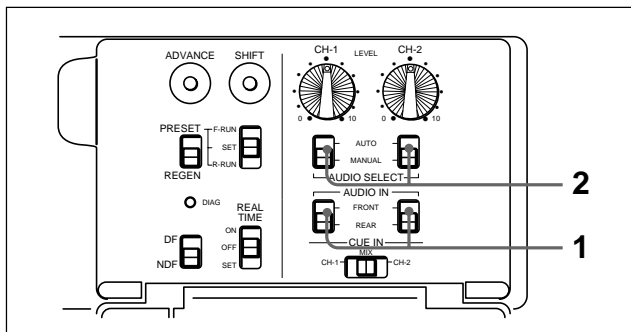

Microphone audio level manual adjustment (1)

- 1 Set the AUDIO IN switch(es) corresponding to the desired channel(s) of the front microphone to be recorded or adjusted to FRONT.
- 2 Set the AUDIO SELECT switch(es) for the desired channel(s) to be recorded or adjusted to MANUAL.

(Continued)

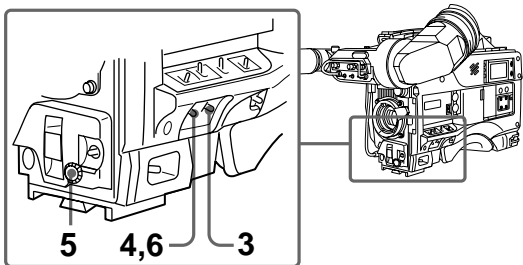

Microphone audio level manual adjustment (2)

- 3** Set the DISPLAY switch to ON.
- 4** Push the MENU switch to CANCEL to display the current audio level (e.g., "AUDIO LEVEL:70").
- 5** Rotate the MIC/MENU knob to adjust the audio level so that at the maximum sound level, the level meter indicates -20 dB.
 - The MIC/MENU knob can be adjusted from 0 to 100 in 101 steps.
 - The second bar from the top may turn on occasionally, but do not allow the top bar to go on. If it goes on, the audio level is too high.

Note

The LEVEL controls on the left side of the camcorder do not function when the AUDIO IN switch is set to FRONT.

- 6** Push the MENU switch to CANCEL to clear the audio level displayed.

4-4 Setting the Time Data

4-4-1 Setting the User Bits

By setting the user bits (up to 8 hexadecimal digits), you can record user information such as the date, time, or scene number on the time code track.

Follow the procedure below to set the user bits.

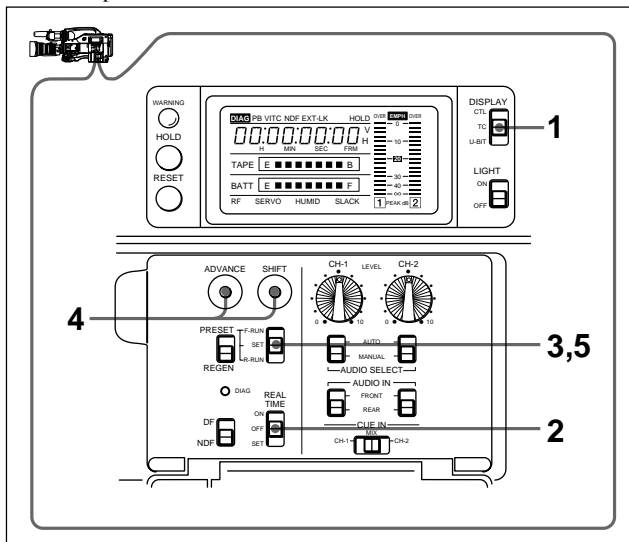

Setting the user bits

- 1 Set the DISPLAY switch to U-BIT.
- 2 Set the REAL TIME switch to OFF.
- 3 Set the F-RUN/SET/R-RUN switch to SET.

(Continued)

-
- 4** Set the user bits by using the SHIFT and ADVANCE buttons.
SHIFT: Selects a digit to set. Each time you press the button, the flashing digit moves one column to the right.
ADVANCE: Increments the value of the flashing digit.

Hexadecimal digits A to F are displayed as follows:

Hexadecimal	A	B	C	D	E	F
Display	<i>A</i>	<i>b</i>	<i>C</i>	<i>d</i>	<i>E</i>	<i>F</i>

Resetting a modified numeric value to 00:00:00:00

To reset a numeric value that was modified, press the RESET button.

- 5** Set the F-RUN/SET/R-RUN switch to F-RUN or R-RUN, corresponding to the desired time code run mode.

The specified user bits will be recorded for both LTC and VITC.

Storing the user bits in memory

The user bits settings are automatically retained in memory even when the power is turned off.

4-4-2 Setting the Time Code

Follow the procedure below to set the time code.

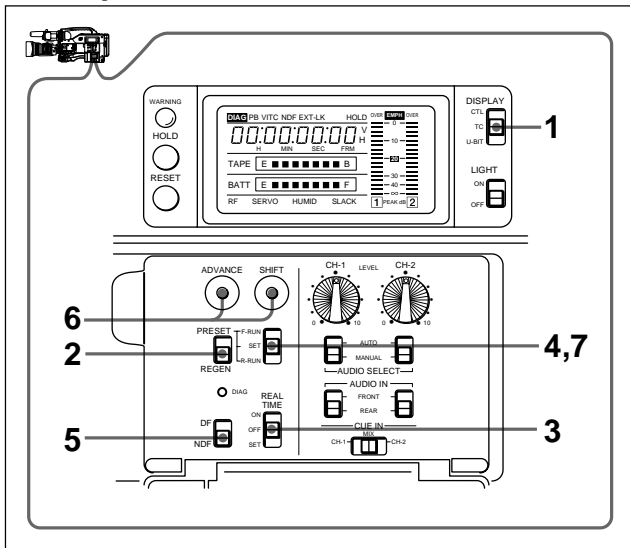

Setting the time code

- 1 Set the DISPLAY switch to TC.
- 2 Set the PRESET/REGEN switch to PRESET.
- 3 Set the REAL TIME switch to ON or OFF.
- 4 Set the F-RUN/SET/R-RUN switch to SET.

(Continued)

-
- 5** Set the DF/NDF switch as necessary.

DF: Drop frame mode

NDF: Non-drop frame mode

Note

The DF/NDF switch is effective only when one of 59.94 I, 60 I, 29.97 PsF and 30 PsF is selected as format in the MULT FORMAT page of the MAINTENANCE manual.

- 6** Using the SHIFT and ADVANCE buttons, set the time code.

SHIFT: Selects a digit to set. Each time you press the button, the flashing digit moves one column to the right.

ADVANCE: Increments the value of the flashing digit.

Resetting a modified numeric value to 00:00:00:00

To reset a numeric value that was modified, press the RESET button.

- 7** Set the F-RUN/SET/R-RUN switch to F-RUN or R-RUN.

F-RUN: Free run. The time code generator keeps running, regardless of the operating state of the VTR.

R-RUN: Recording run. The time code generator runs only while recording.

Make the time code continuous

When the F-RUN/SET/R-RUN switch is set to R-RUN, recording a number of scenes on the tape normally produces continuous time codes. If, however, you take the cassette out at some point, the time code will no longer be continuous.

To make the time code continuous, follow the procedure below.

- 1** Set the PRESET/REGEN switch to REGEN.

- 2** Use the tape transport buttons to play back.

- 3** Watching the playback, find the point of the previous recording on the tape from which you wish to continue recording, and press the STOP button.

4 Press the RET button on the lens.

This reads the previous recording and synchronizes the internal time code generator, thus allowing the new time code recorded to follow on consecutively.

Or press the assignable switch if it is assigned to the LENS RET function on the OTHERS page of the OPERATION menu.

For details, see “4-8-8 Setting the D5600K Mode, Assignable Switches and PB VIDEO” on page 4-66.

4-4-3 Entering the Real Time in the VITC

Follow the procedure below to enter the real time in the VITC.

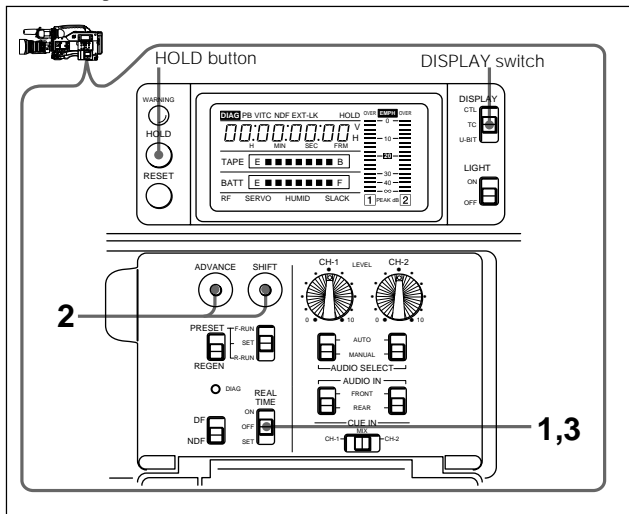

Entering the real time in the VITC

(Continued)

-
- 1 Set the REAL TIME switch to SET.
 - 2 Use the ADVANCE and SHIFT buttons to set the real time.
 - 3 Set the REAL TIME switch to ON.

The real time is recorded in the VITC, and the user bits that were set are recorded in the LTC.

4

By flipping the internal switch, you can enter the user bits in the VITC and the real time in the LTC.

Refer to the Maintenance Manual for more information.

Displaying the user bits being recorded in the VITC

Set the DISPLAY switch to U-BIT and then press and hold down the HOLD button. The user bits that are being recorded in the VITC are displayed while the HOLD button is pressed.

4-4-4 Synchronizing the Time Code

You can synchronize the internal time code generator of this camcorder with an external generator for the regeneration of an external time code. You can also synchronize the time code generators of external VTRs with the internal generator of this camcorder.

Connections for time code synchronization

Connect both the reference video signal and the external time code as illustrated below.

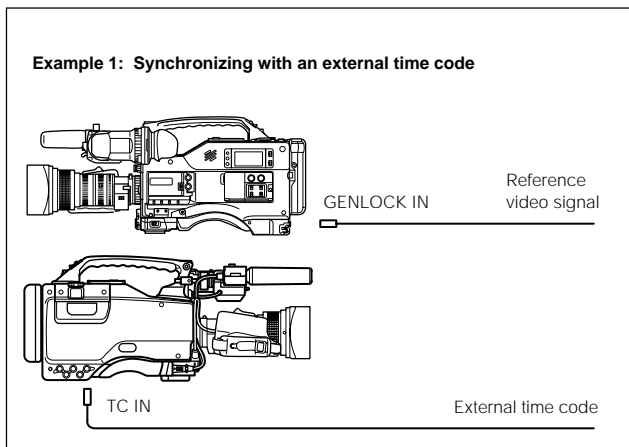

(Continued)

Example 2: Interconnecting a number of camcorders for time code synchronization

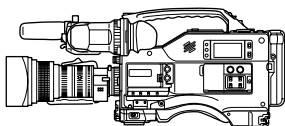

Master camcorder

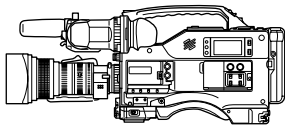

Camcorder to be synchronized

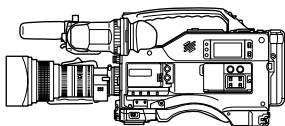

Camcorder to be synchronized

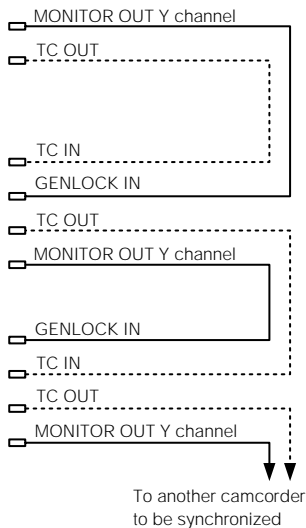

Procedure for time code synchronization

Follow the procedure below to synchronize the time code.

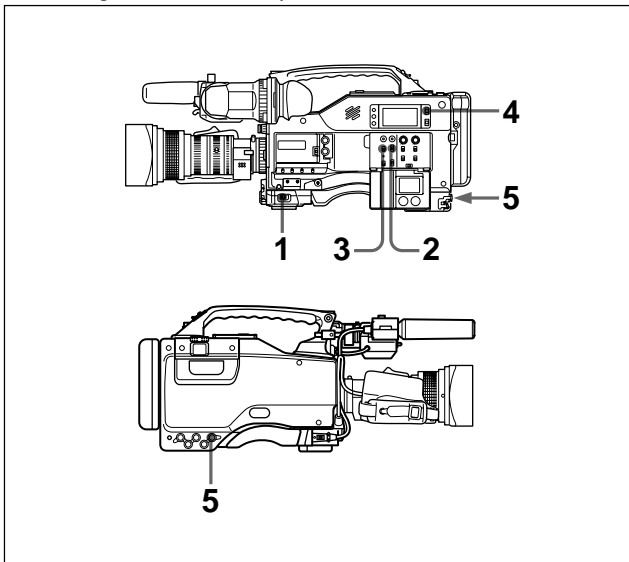

Synchronizing the time code

- 1** Turn the POWER switch to ON.
- 2** Set the F-RUN/SET/R-RUN switch to F-RUN.
- 3** Set the PRESET/REGEN switch to PRESET.

(Continued)

4 Set the DISPLAY switch to TC.

5 Supply the time code to the TC IN connector and reference video signals that comply with the SMPTE time code standard and are in the proper phase relationship to the GENLOCK IN connector.

This operation synchronizes the internal time code generator with the external time code. After synchronization, you can disconnect the external time code without losing the synchronization. However, the synchronization will be disrupted if you connect or disconnect the time code during recording.

Note

- When you finish the above procedure, the time code is immediately synchronized with the external time code and the counter display will show the value of the external time code. However, wait for a few seconds until the sync generator stabilizes before recording.
- If the frequency of the reference video signal is not the same as the frame frequency of the camcorder, the camera cannot be correctly genlocked. In such a case, the time code is not correctly synchronized with the external time code.

User bit settings during time code synchronization

When the time code is synchronized, only the time data is synchronized with the external time code value. Therefore, the user bits can have their own settings for each camcorder. You can also synchronize the user bits with external user bit data.

For more information, refer to the Maintenance Manual.

Releasing the time code synchronization

First disconnect the external time code, then set the F-RUN/SET/R-RUN switch to R-RUN.

Changing the power supply from the battery pack to an external power supply during time code synchronization

To maintain a continuous power supply, connect the external power supply to the DC IN connector before removing the battery pack. You may lose time code synchronization if you remove the battery pack first.

Camera synchronization during time code synchronization

During time code synchronization, the camera is genlocked to the reference video signal input from the GENLOCK IN connector.

4-5 Setup Menu Display on the Viewfinder Screen

If the VF DISP switch is set to MENU, the OPERATION menu is displayed on the viewfinder screen.

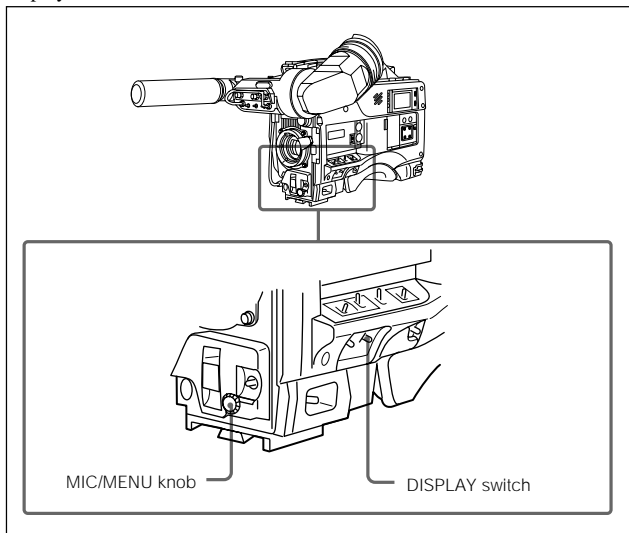

TOP MENU

The menus of the camcorder are classified into categories according to the frequency of use, number of users and so on. The TOP MENU allows you to select the desired menu categories.

To display the TOP MENU screen:

Set the DISPLAY switch from the OFF position to the MENU position while holding down the MIC/MENU knob.

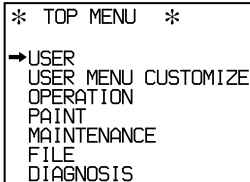

```
* TOP MENU *
→USER
USER MENU CUSTOMIZE
OPERATION
PAINT
MAINTENANCE
FILE
DIAGNOSIS
```

Note

The contents of the TOP MENU will differ according to IF circuit board switch settings inside the HDW-F900 camcorder.

Refer to the Maintenance Manual for more information.

The TOP MENU has the following submenus.

• USER menu

This menu allows you to register items used frequently. This menu can contain up to 60 pages. You can add or delete items using the USER MENU CUSTOMIZE menu.

• USER MENU CUSTOMIZE menu

This menu allows you to add desired menu pages or items, or delete them to suit your needs.

For detailed information, see “4-7 Using the USER Menu” on page 4-38.

(Continued)

- **OPERATION menu:**

This menu contains items for changing settings according to conditions related to the subject when a normal cameraman is operating the camcorder. This menu is normally displayed when the DISPLAY switch is changed to MENU.

For detailed information on adjustments and setups using this OPERATION menu, see “4-8 Setup Using the OPERATION Menu” on page 4-47.

- **PAINT menu**

This menu contains items for making detailed image adjustments while using a waveform monitor to monitor the waveforms output by the camera. Usually, the support of a video engineer is required to use this menu. Although you can also use an external remote control panel or master setup unit to set the items on this menu, this menu is effective when using the camcorder by itself outdoors. This menu allows you to perform almost the same settings as those of the PAINT menu of the MSU-700A/750 Master Setup Unit (not supplied).

- **MAINTENANCE menu**

This menu contains items for performing camera maintenance operations such as changing the system or infrequently used paint items. This menu allows you to perform almost the same settings as those of the MAINTENANCE menu of the MSU-700A/750 Master Setup Unit (not supplied).

- **FILE menu**

This menu is used for performing file operations such as writing the reference file.

- **DIAGNOSIS menu**

This menu enables you to confirm the VTR status or a failed circuit board.

To return to the TOP menu

The following two methods are available:

- Point the arrow (→) to TOP on the right top on each page, then press the MIC/MENU knob.
- Push the MENU switch to the CANCEL side twice.

4-5-1 Basic Use of the Setup Menu

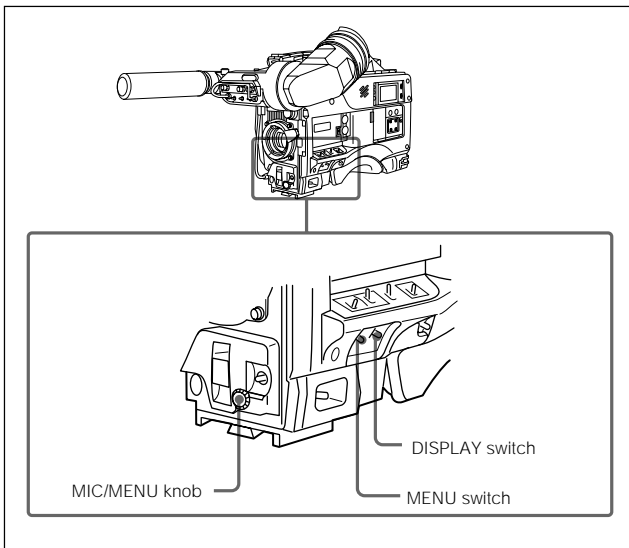

- 1** Switch the DISPLAY switch from OFF to MENU.

The OPERATION menu will be displayed.

(Continued)

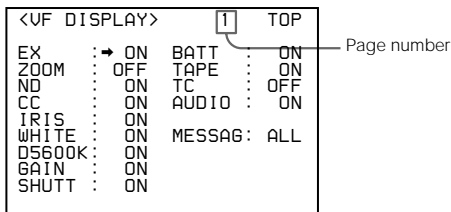

- 2** Turn the MIC/MENU knob until the desired page appears.
- 3** Push the MIC/MENU knob.

The arrow (→) points to the currently selected item.

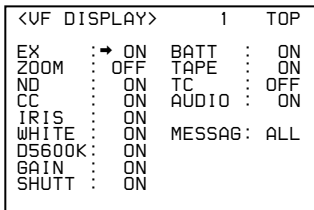

- 4** Turn the MIC/MENU knob to move the arrow (→) to the item you want to set.
- 5** Push the MIC/MENU knob.

The arrow (→) changes to a flashing question mark (?).

-
- 6** Turn the MIC/MENU knob to change the setting.

If you turn the knob quickly, the numeric value changes rapidly. If you turn it slowly, you can make minute adjustments.

Canceling a modified value

If you push the MENU switch to CANCEL before pushing the MIC/MENU knob in step 7, the setting will return to its original value.

Interrupting setting operations

If you turn the DISPLAY switch to OFF, the menu screen display will disappear. When you turn the DISPLAY switch to MENU again, the values that were displayed when you interrupted the setting operations will reappear so you can continue making settings.

- 7** Push the MIC/MENU knob.

The question mark (?) changes to an arrow (→) to confirm the setting.

- 8** To continue changing the settings of items on the same page, repeat steps 4 to 7.

To move to another page

- 1** Turn the MIC/MENU knob to move the arrow (→) to the page number, then press the MIC/MENU knob.

Or, when the arrow mark is placed at a position other than the page number, push the MENU switch to CANCEL.

The camcorder is in page selecting mode.

- 2** Turn the MIC/MENU knob until the desired page appears.

To end menu operations

Turn the DISPLAY switch to OFF.

4-6 Status Display on the Viewfinder Screen

The viewfinder screen displays not only the video picture but also characters and messages indicating the camcorder settings and operating status, a center marker, a safety zone marker, etc.

When the DISPLAY switch is set to ON, the items for which an “ON” setting was made in the VF DISPLAY page of the OPERATION menu or with related switches are displayed at the top and bottom of the screen. The messages that give details of the settings and adjustment progress and results can also be made to appear for about 3 seconds while settings are being changed, during adjustment, and after adjustment.

For information about marker display, see Section 4-8-3 “Setting the Marker Display” (page 4-55). For information about the display item selection, see Section 4-8-1 “Selecting the Display Items” (page 4-48).

4-6-1 Layout of the Status Display on the Viewfinder Screen

All items that can be displayed on the viewfinder screen are shown below.

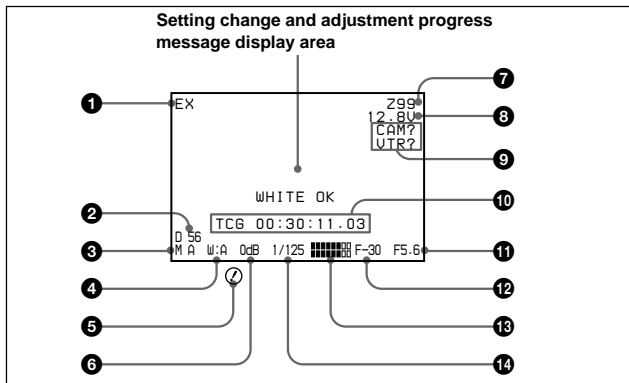

❶ Extender

EX is displayed when a lens extender is used.

❷ D5600K mode

This indicator is displayed when D5600K mode is used.

❸ Filter

This indicator indicates the currently selected filter types. The digit (1 to 4) indicates the ND filter selection, and the letter (A, B, C, or D) indicates the CC filter selection.

❹ White balance memory

This indicator indicates the currently selected white balance automatic adjustment memory.

W:A: Displayed when the WHITE BAL switch is set to A.

W:B: Displayed when the WHITE BAL switch is set to B.

W:P: Displayed when the WHITE BAL switch is set to PRST.

❺ ! indicator

This indicator lights when the setting of the camcorder is changed from the normal setting to other settings which are different from ones set on the “!” IND page of the OPERATION menu.

For details, see “4-8-2 Selecting the Items for Which the ‘!’ IND is to Light” on page 4-50.

❻ Gain

This indicator indicates the gain (in dB) of the video amplifier, as set by the GAIN selector.

❼ Zoom position

This indicator indicates the length between wide angle and telephoto. The indicator ranges from z0 to z99.

(Continued)

8 Power voltage

This indicator indicates the power voltage.

9 Self-diagnostics

CAM ?: When a fault has been detected in the position related to the camera, this indicator appears as a lighting question mark.

VTR ?: When a fault has been detected in the position related to the VTR, this indicator appears as a lighting question mark.

10 Time code

This indicator indicates the time code value.

11 Iris setting

This indicator indicates the f-stop (iris setting) of the lens. When the lens is fully opened, the iris-setting is highlighted.

For detailed information on how to set the fully open iris, see the Maintenance Manual.

12 Remaining tape

This indicator indicates the remaining tape recording time (in minutes) of the VTR.

Example of remaining tape indicator

Display	Tape time remaining
F - 30	Full to 30 minutes
30 - 25	30 to 25 minutes
25 - 20	25 to 20 minutes
20 - 15	20 to 15 minutes
15 - 10	15 to 10 minutes
10 - 5	10 to 5 minutes
5 - 0	5 to 2 minutes
5 - 0 (flashing)	Less than 2 minutes

13 Audio level

These indicators indicate the level of audio channel 1 and channel 2. The peak indication of the VTR level meter is related as follows to the audio level when an 1-kHz sine wave is input.

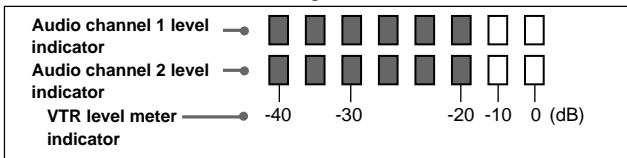

14 Shutter speed

This indicator indicates the shutter speed. However, if the SHUTTER switch is set to OFF, nothing is displayed.

4-7 Using the USER Menu

You can select desired pages from the OPERATION, PAINT, MAINTENANCE, FILE, and DIAGNOSIS menu pages, and copy and set them on the USER Menu. If you set pages frequently used on the USER Menu, you can easily call the pages and use them.

On the USER Menu, USER PAGE 1 through USER PAGE 5 are provided. You can place up to ten desired menu items on each of these pages.

4

4-7-1 Setting Desired Menu Pages on the USER Menu

- 1 Display the TOP MENU screen.

For details on displaying the TOP MENU screen, see "To display the TOP MENU screen:" on page 4-29.

- 2 Turn the MIC/MENU knob to select USER MENU CUSTOMIZE, then push the MIC/MENU knob.

The PAGE EDIT screen appears.

```
<PAGE EDIT>      111  TOP
PAGE: 1 / 1
→1: <USER PAGE 1>
2: <USER PAGE 2>
3: <USER PAGE 3>
4: <USER PAGE 4>
5: <USER PAGE 5>
6: -----
7: -----
8: -----
9: -----
```

Upon setting of numbers 1 through 5, USER PAGE 1 through USER PAGE 5 have been set. You can change these settings as desired.

-
- 3** Turn the MIC/MENU knob to select the number for which the menu page is to be set, then push the MIC/MENU knob.

The operation select screen appears.

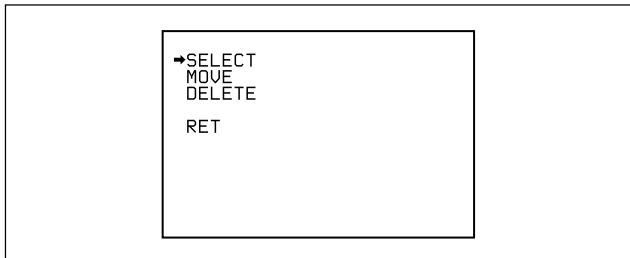

- 4** Turn the MIC/MENU knob to select SELECT, and push the MIC/MENU knob.

The PAGE SELECT screen appears.

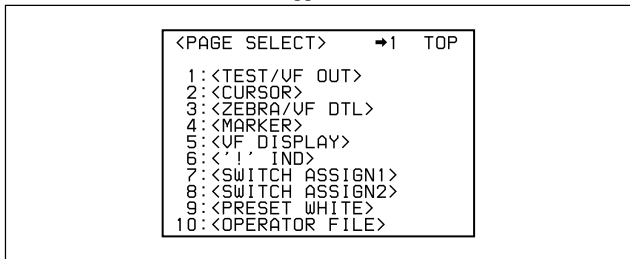

(Continued)

-
- 5** Select a menu page to be set, following the procedure below.

To select from among menu pages 1 through 10

Turn the MIC/MENU knob to select a menu page to be set, then push the MIC/MENU knob.

To select pages 11 and after

- ① Turn the MIC/MENU knob to move the arrow (→) to the figure at the top of the screen, then push the MIC/MENU knob.

The arrow (→) changes to a question mark (?).

- ② Turn the MIC/MENU knob until the desired menu page appears, then push the MIC/MENU knob.

The question mark (?) changes to an arrow (→).

- ③ Turn the MIC/MENU knob to select a menu page to be set, then push the MIC/MENU knob.

The selected menu page is set on the USER Menu, and the screen returns to the TOP MENU screen.

To change the order of the pages

- 1** Display the TOP MENU screen.
- 2** Turn the MIC/MENU knob to select USER MENU CUSTOMIZE, then push the MIC/MENU knob.

The PAGE EDIT screen appears.

-
- 3 Turn the MIC/MENU knob to select the menu page to be moved, then push the MIC/MENU knob.

The operation select screen appears.

- 4 Turn the MIC/MENU knob to select MOVE, then push the MIC/MENU knob.

The PAGE EDIT screen is restored.

- 5 Turn the MIC/MENU knob to move the arrow (→) to the position where the selected page is to be moved, then push the MIC/MENU knob.

The selected page moves to the position pointed by the arrow (→).

To delete a page

- 1 Display the TOP MENU screen.
- 2 Turn the MIC/MENU knob to select USER MENU CUSTOMIZE, then push the MIC/MENU knob.

The PAGE EDIT screen appears.

- 3 Turn the MIC/MENU knob to select the menu page to be deleted, then push the MIC/MENU knob.

The operation select screen appears.

- 4 Turn the MIC/MENU knob to select DELETE, then push the MIC/MENU knob.

The selected menu page is deleted, and the PAGE EDIT screen is restored.

4-7-2 Setting Desired Items on a USER PAGE

To set desired items on a USER PAGE, follow the procedure below.

- 1 Set USER PAGE 1 through USER PAGE 5.

For setting USER PAGE 1 through USER PAGE 5, see "4-7-1 Setting Desired Menu Pages on the USER Menu" on page 4-38.

- 2 Display the TOP MENU screen.

For details on displaying the TOP MENU screen, see "To display the TOP MENU screen:" on page 4-29.

- 3 Turn the MIC/MENU knob to select USER MENU CUSTOMIZE, then push the MIC/MENU knob.

The PAGE EDIT screen appears.

- 4 Turn the MIC/MENU knob to move the arrow (→) to U1 at the top of the screen, then push the MIC/MENU knob.

The arrow (→) changes to a question mark (?).

- 5 Turn the MIC/MENU knob to select any of U2 through U6, then push the MIC/MENU knob.

A USER PAGE setting screen appears.

U2: USER PAGE 1 setting screen USER P1 EDIT

U3: USER PAGE 2 setting screen USER P2 EDIT

U4: USER PAGE 3 setting screen USER P3 EDIT

U5: USER PAGE 4 setting screen USER P4 EDIT

U6: USER PAGE 5 setting screen USER P5 EDIT

```
<USER P1 EDIT>   U2  TOP
```

```
-----
-----
-----
-----
-----
-----
-----
-----
```

- 6** Turn the MIC/MENU knob to move the arrow (→) to the first line, then push the MIC/MENU knob.

The ITEM SELECT screen appears.

```
<ITEM SELECT>   1  RET
```

```
  1:ALL PRESET
  2:APL RATIO
  3:ASPECT IND SW
  4:ASPECT MOD
  5:ASSIGN DIM
  → 6:ASSIGNABLE
  7:AT SET ABS
  8:AT SET ACC
  9:AT SET AWS
 10:AT SET BLK
```

- 7** Select an item to be set, following the procedure below.

To select from among items 1 through 10

- ① Turn the MIC/MENU knob to select an item to be set, then push the MIC/MENU knob.

The operation select screen appears

(Continued)

-
- ② Turn the MIC/MENU knob to select SELECT, then push the MIC/MENU knob.

The USER P1 EDIT screen is restored, and the selected item is displayed.

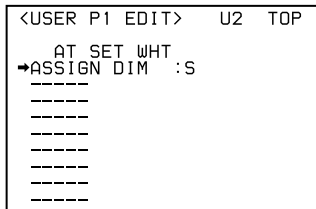

The screenshot shows a menu titled "<USER P1 EDIT> U2 TOP". Below the title are several menu items: "AT SET WHT", "→ASSIGN DIM :S", and seven dashed lines representing other menu options. The arrow points to the second item, "ASSIGN DIM :S".

To select items 11 and after

- ① Turn the MIC/MENU knob to move the arrow (→) to the figure at the top of the screen, then push the MIC/MENU knob.

The arrow (→) changes to the question mark.

- ② Turn the MIC/MENU knob until a desired item appears, then push the MIC/MENU knob.

The question mark (?) changes to the arrow (→).

- ③ Turn the MIC/MENU knob to select an item to be set, then push the MIC/MENU knob.

The operation select screen appears.

-
- ④ Turn the MIC/MENU knob to select SELECT, then push the MIC/MENU knob.

The USER P1 EDIT screen is restored, and the selected item is displayed.

Repeat steps 6 and 7 as required.

- 8 When setting of all items on the page is completed, turn the MIC/MENU knob to move the arrow (→) to TOP at the top of the screen, then push the MIC/MENU knob.

The TOP MENU screen is restored.

To change the order of the items

You can change the order of the items by the same method as that for the menu pages.

To delete an item

You can delete an item by the same method as that for the menu pages.

4-7-3 Displaying the USER Menu

- 1 Display the TOP MENU screen.

For details on displaying the TOP MENU screen, see "To display the TOP MENU screen:" on page 4-29.

- 2 Turn the MIC/MENU knob to select USER, then push the MIC/MENU knob.

The menu page set for setting number 1 on the PAGE EDIT screen appears.

To display other USER pages

- 1** Turn the MIC/MENU knob to move the arrow (→) to the figure at the top of the screen, then push the MIC/MENU knob.

The arrow (→) changes to a question mark (?).

- 2** Turn the MIC/MENU knob until the desired menu page appears, then push the MIC/MENU knob.

The selected page is displayed.

4-8 Setup Using the OPERATION Menu

To set up or adjust the camcorder, use the OPERATION menu. The items that can be set up or adjusted by using the OPERATION menu are listed in the table below.

Items that can be set up or adjusted by using the OPERATION menu

Adjustment or setup item	Page	Page name	Reference
Selection of viewfinder screen indicators	1	VF DISPLAY	Page 4-48
'!' IND setup	2	'!' IND	Page 4-50
Marker setup	3	MARKER	Page 4-55
Gain selector setup	4	GAIN SW	Page 4-58
Viewfinder setup	5	ZEBRA/VF DTL	Page 4-60
Auto iris setup	6	AUTO IRIS	Page 4-62
Battery setup	7	BATT ALARM	Page 4-64
D5600K, assignable switches setup and PB VIDEO	8	OTHERS	Page 4-66
Operator file	9	OPERATOR FILE	Page 4-69
Lens file selection	10	LENS FILE	Page 4-70

For information about other adjustment or setup operations, see Section 4-9 “Paint Menu” (page 4-72), Section 4-10 “Maintenance Menu” (page 4-85), or refer to the Maintenance Manual.

4-8-1 Selecting the Display Items

To select the items to be displayed on the viewfinder screen from the VF DISPLAY page of the OPERATION menu, turn on or off the indication next to each item.

Follow the procedure below to select the items to be displayed on the viewfinder screen.

- 4** **1** Set the DISPLAY switch to MENU.

The OPERATION menu appears on the viewfinder screen.

- 2** Turn the MIC/MENU knob until the VF DISPLAY page appears, and push the MIC/MENU knob.

The VF DISPLAY page appears.

The current setting of an item appears to the right of the item.

<VF DISPLAY>		1	TOP
EX	: → ON	BATT	: ON
ZOOM	: OFF	TAPE	: ON
ND	: ON	TC	: OFF
CC	: ON	AUDIO	: ON
IRIS	: ON	MESSAG	: ALL
WHITE	: ON		
D5600K	: ON		
GAIN	: ON		
SHUTT	: ON		

You can select the following items to be displayed on the viewfinder screen.

Item	Contents
EX	Extender indicator ^{a)}
ZOOM	Zoom position indicator ^{a)}
ND	Type of the ND filter ^{a)}
CC	Type of the CC filter ^{a)}
IRIS	Iris opening indicator ^{a)}
WHITE	White balance memory indicator ^{a)}
D5600K	D5600K mode indicator ^{a)}
GAIN	Gain indicator ^{a)}
SHUTT	Shutter speed and ECS mode indicator ^{a)}
BATT	Power voltage indicator ^{a)}
TAPE	Remaining tape indicator ^{a)}
TC	Time code indicator ^{a)}
AUDIO	Audio level indicator ^{a)}
MESSAGE	Settings for the message to be displayed
ALL	Indicates all of the messages.
WRM	Indicates warning messages and higher.
AT	Indicates the auto setup information and higher.
OFF	Does not indicate any messages.

a) Three settings are available:

ON: Displays.

OFF: Does not display.

3S: Displays the new setting for about 3 seconds when the setting is changed from the current setting.

(Continued)

-
- 3** Turn the MIC/MENU knob to move the arrow (→) to the item you want to set, and push the MIC/MENU knob.

The arrow (→) changes to a question mark (?).

- 4** Turn the MIC/MENU knob to change the desired setting, and push the MIC/MENU knob.

The question mark (?) changes back to the arrow (→) to execute the setting.

- 5** To continue setting other items, repeat steps 3 and 4.

- 6** To end menu operations, turn the DISPLAY switch to ON.

The menu disappears from the viewfinder screen, and the display indicating the current status of the camcorder appears along the top and bottom of the viewfinder screen.

4-8-2 Selecting the Items for Which the '! IND is to Light

To select the items for which the '! indicator is to light up on the viewfinder screen, use the '! IND page of the OPERATION menu.

Follow the procedure below to select these items.

- 1** Set the DISPLAY switch to MENU.

-
- 2** Turn the MIC/MENU knob until the '!' IND page appears, and push the MIC/MENU knob.

The current setting of an item appears to the right of the item.

<'!' IND>		2	TOP
	[IND]	[NORMAL]	
ND	: → ON	1---	
CC	: ON	-B--	
WHITE	: ON	--B	
D5600K	: ON	OFF	
GAIN	: ON	0DB	
SHUTT	: ON	OFF	
FAN	: ON	AUTO1	
EXT	: ON	OFF	
FORMAT	: ON	23.98P _s F	

The above '!' IND page indicates the default settings.

All items have been set to ON at the factory. However, you can change the normal condition as to whether the '!' indicator lights or does not light at the NORMAL column.

(Continued)

The following table shows the brief explanation about the default settings displayed on the '! IND page.

Item	Contents
ND	Goes off when the ND filter 1 is selected.
CC	Goes off when the CC filter B is selected.
WHITE	Goes off when the WHITE BAL switch (white balance automatic adjustment memory) is set to the position B.
D5600K	Goes off when D5600K is set to OFF on the OTHERS page of the OPERATION menu.
GAIN	Goes off when the GAIN switch is set to L.
SHUTTER	Goes off when the electronic shutter is not used.
FAN	Goes off when FAN mode is set to AUTO 1 on the MAINTENANCE menu.
EXT	Goes off when the lens extender is not in use (i.e., EX is OFF).
FORMAT	Goes off when the format 23.98 PsF is selected.

3 Perform the desired settings for each item.

Select whether the '! indicator lights or not in the IND column. When you select the option that the '! IND lights, select the conditions for lighting in the NORMAL column. That is, you can select the normal condition where the '! indicator does not light, in the NORMAL column.

-
- ① Turn the MIC/MENU knob to move the arrow (→) to the item you want to see in the IND column, and push the MIC/MENU knob.

The arrow (→) changes to a question mark (?).

- ② Set the setting to ON or OFF by turning the MIC/MENU knob, and push the MIC/MENU knob.

The question mark (?) changes back to the arrow (→) to confirm the setting.

When you select ON in step ②, then perform the setting for the normal operation status in the NORMAL column. That is, select the setting so that the '!' indicator does not light.

When you select OFF in step ②, go to step 4.

- ③ Turn the MIC/MENU knob to move the arrow (→) to the NORMAL column of the item you selected in step ①, and push the MIC/MENU knob.

The arrow (→) changes to a question mark (?).

(Continued)

- 4
- ④ Turn the MIC/MENU knob until the desired setting (that is, such a setting that the '!' IND does not light) is displayed, and push the MIC/MENU knob.

Item	Contents in the NORMAL column
ND	Types of the ND filter, 1, 2, 3 or 4
CC	Types of the CC filter, A, B, C or D
WHITE	White balance automatic adjustment memory, P (PRST), A or B
D5600K	ON or OFF of the D5600K mode
GAIN	Switch position L, M or H
SHUTTER	ON or OFF (Standard mode and ECS mode)
FAN	AUTO 1, AUTO 2, MIN or MAX
EXT	ON or OFF of the extender
FORMAT	Video format (multi format): 59.94I, 60I, 30PsF, 29.97PsF, 50I, 25PsF, 24PsF or 23.98PsF

The question mark (?) changes back to the arrow (→) to execute the setting.

Example: To display the '!' indicator when ND filter 1 or 2 is selected

Select ON for the item ND in the IND column, then display "1 2 - -" in the NORMAL column and execute the setting.

- 4 To continue setting other items, repeat step 3.
- 5 To end menu operations, turn the DISPLAY switch to ON.

The menu disappears from the viewfinder screen, and the display indicating the current status of the camcorder appears along the top and bottom of the viewfinder screen.

4-8-3 Setting the Marker Display

Use the MARKER page of the OPERATION menu to specify the display setting for the various markers and to turn the mask function which dims all areas except the markers on or off.

Follow the procedure below to select the marker display.

- 1 Set the DISPLAY switch to MENU.
- 2 Turn the MIC/MENU knob until the MARKER page appears, and push the MIC/MENU knob.

The current setting of an item appears to the right of the item.

<MARKER>		3	TOP
MARKER	: →	ON	
CENTER	:	ON	3
SAFETY ZONE	:	ON	90.0%
EFFECT	:	OFF	
ASPECT MODE	:	4:3	
MASK	:	OFF	50
VAR WIDTH	:	--	

(Continued)

You can select displaying or not-displaying for the following item.

Item	Contents
MARKER ^{a)}	Not to display all markers, set to OFF.
CENTER	To display the center marker, set to ON. If this item is set to ON, you can select the type of center marker (1 to 4).
SAFETY ZONE	To display the safety zone, set to ON. If this item is set to ON, you can set the safety zone range (80%, 90%, 92.5%, or 95%).
EFFECT	To display the effective pixel area, set to ON.
ASPECT MODE	Select the aspect mode among 16:9, 15:9, 14:9, 13:9, 4:3, VAR H, VAR V, VISTA 1 or VIST 2.
MASK	To make the areas out of the selected aspect marker dimmer, set to ON. If this item is set to ON, you can set the mask level (0 to 100 %).
VAR WIDTH	Effective only when VAR H or VAR V is selected at the ASPECT MODE item. VAR H: You can change the aspect size horizontally. VAR V: You can change the aspect size vertically.

- a) The DISPLAY/ASPECT switch on the viewfinder allows you to display or not display the corresponding item. The menu settings are also changed according to the operation of this switch.

3 Perform the settings for each item.
First, change the ON or OFF setting. Then, if there are choices of settings when you select ON for the item to be set, select the desired settings.

- ① Turn the MIC/MENU knob to move the arrow (→) to the item you want to set, and push the MIC/MENU knob.

The arrow (→) changes to a question mark (?).

- ② Turn the MIC/MENU knob to change the desired setting, and push the MIC/MENU knob.

The question mark (?) changes back to the arrow (→) to execute the setting.

4 To continue setting other items, repeat step 3.

5 To end menu operations, turn the DISPLAY switch to ON.

The menu disappears from the viewfinder screen, and the display indicating the current status of the camcorder appears along the top and bottom of the viewfinder screen.

4-8-4 Setting the GAIN Selector Values

Before using the camcorder, use the GAIN SW page of the OPERATION menu to set the gains corresponding to the L, M, and H positions of the GAIN selector, which switches the gain of the video amplifier.

Follow the procedure below to set the gain.

4 **1** Set the DISPLAY switch to MENU.

2 Turn the MIC/MENU knob until the GAIN SW page appears, and push the MIC/MENU knob.

The GAIN SW page appears.

The current setting of an item appears to the right of the item.

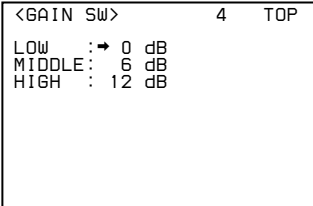

The screenshot shows a menu titled '<GAIN SW>' with the number '4' and the word 'TOP' in the upper right corner. Below the title, there are three lines of text: 'LOW : → 0 dB', 'MIDDLE : 6 dB', and 'HIGH : 12 dB'. The arrow points to the '0' in the LOW line, indicating it is the current setting.

Gain Position	Gain Value
LOW	0 dB
MIDDLE	6 dB
HIGH	12 dB

Item	Content
LOW	Sets the gain value corresponding to the L position of the GAIN selector.
MIDDLE	Set the gain value corresponding to the M position of the GAIN selector.
HIGH	Set the gain value corresponding to the H position of the GAIN selector.

- 3** Turn the MIC/MENU knob to move the arrow (→) to the item you want to set, and push the MIC/MENU knob.

The arrow (→) changes to a question mark (?).

- 4** Turn the MIC/MENU knob to change the desired setting, and push the MIC/MENU knob.

The question mark (?) changes back to the arrow (→) to confirm the setting.

Any of -3, 0, 3, 6, 12, or 18 dB can be set for each of the L, M, and H positions, in any sequence.

To change the gain corresponding to another switch position, return to step 3.

- 5** To end menu operations, turn the DISPLAY switch to ON.

The menu disappears from the viewfinder screen, and the display indicating the current status of the camcorder appears along the top and bottom of the viewfinder screen.

4-8-5 Setting the Viewfinder

Use the ZEBRA/VF DTL page of the OPERATION menu to select items related to the viewfinder.

- 1 Set the DISPLAY switch to MENU.
- 2 Turn the MIC/MENU knob until the ZEBRA/VF DTL page appears, and push the MIC/MENU knob.

The ZEBRA/VF DTL page appears.

The current setting of an item appears to the right of the item.

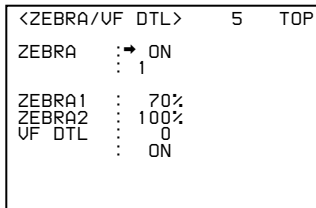

```
<ZEBRA/VF DTL>      5  TOP
ZEBRA   : → ON
          : 1
ZEBRA1  : 70%
ZEBRA2  : 100%
VF DTL  : 0
          : ON
```

Item	Content
ZEBRA	Turns the zebra display on or off and selects the zebra display level.
ZEBRA 1	Adjusts the level of the zebra (70%) display. (50~70~82%)
ZEBRA 2	Adjusts the level of the zebra (100%) display. (88~100~112%)
VF DTL	Adjusts the sharpness in the viewfinder (-99 to 0 to 99). ^{a)} Turns the VF detail function on or off and adjusts the level.

a) The sharpness setting in the viewfinder does not affect the recorded image.

- 3 Turn the MIC/MENU knob to move the arrow (→) to the item you want to set, and push the MIC/MENU knob.

The arrow (→) changes to a question mark (?).

- 4 Turn the MIC/MENU knob to change the desired setting, and push the MIC/MENU knob.

The question mark (?) changes back to the arrow (→) to confirm the setting.

- 5 To continue setting other items, repeat steps 3 and 4.

- 6 To end menu operations, turn the DISPLAY switch to ON.

The menu disappears from the viewfinder screen, and the display indicating the current status of the camcorder appears along the top and bottom of the viewfinder screen.

4-8-6 Setting the Automatic Iris

Use the AUTO IRIS page of the OPERATION menu to select items related to the automatic iris.

- 1 Set the DISPLAY switch to MENU.
- 2 Turn the MIC/MENU knob until the AUTO IRIS page appears, and push the MIC/MENU knob.

The AUTO IRIS page appears.

The current setting of an item appears to the right of the item.

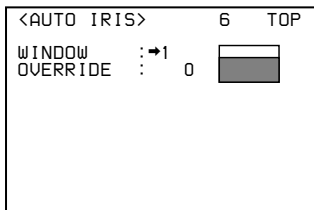

Item	Content
WINDOW	Selects the automatic iris window. ^{a)}
OVERRIDE	Sets the override to temporarily change the reference value for brightness of the automatic iris level (-99 (fully closed iris) to +99 (fully open iris))

- a) The shaded parts in the illustrations below indicate the area where light detection occurs.

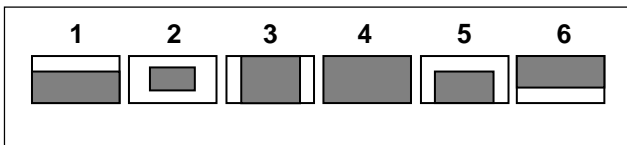

Note

The override returns to 0 when you turn the camcorder off, then on again.

- 3** Turn the MIC/MENU knob to move the arrow (→) to the item you want to set, and push the MIC/MENU knob.

The arrow (→) changes to a question mark (?).

- 4** Turn the MIC/MENU knob to change the desired setting, and push the MIC/MENU knob.

The question mark (?) changes back to the arrow (→) to confirm the setting.

- 5** To continue setting other items, repeat steps 3 and 4.

(Continued)

-
- 6** To end menu operations, turn the DISPLAY switch to ON.

The menu disappears from the viewfinder screen, and the display indicating the current status of the camcorder appears along the top and bottom of the viewfinder screen.

4-8-7 Setting the Battery

4

Use the BATT ALARM page of the OPERATION menu to select the type of battery that is currently being used. (When you change this setting, the alarm voltage automatically changes to the value set on the MAINTENANCE menu.)

- 1** Set the DISPLAY switch to MENU.
- 2** Turn the MIC/MENU knob until the BATT ALARM page appears, and push the MIC/MENU knob.

The BATT ALARM page appears.

The current setting of an item appears to the right of the item.

```
<BATT ALARM>      7  TOP
BATT
TYPE:→LITHIUM
BEFORE END:11.5V
END          :11.0V

DC IN
TYPE:→AC ADP
BEFORE END:  --
END          :  --
```

Item	Content
BATT	
TYPE	Selects the type of the battery (LITHIUM, DIGITAL, OTHERS1 OTHERS2, AC ADP).
BEFORE END	Displays the ALARM voltage set on the MAINTENANCE menu. ^{a)}
END	Displays the END (shutdown) voltage set on the MAINTENANCE menu. ^{a)}
DC IN	
TYPE	Selects the type of the battery input to the DC IN connector (LITHIUM, DIGITAL, OTHERS1, OTHERS2, AC ADP)
BEFORE END	Displays the ALARM voltage set on the MAINTENANCE menu. ^{a)}
END	Displays the END voltage set on the MAINTENANCE menu.

a) When AC ADP is selected, “ - - ” appears at the position where the voltage should be displayed, that is, no values are displayed.

- 3** Turn the MIC/MENU knob to move the arrow (→) to the item you want to set, and push the MIC/MENU knob.

The arrow (→) changes to a question mark (?).

- 4** Turn the MIC/MENU knob to change the desired setting, and push the MIC/MENU knob.

The question mark (?) changes back to the arrow (→) to confirm the setting.

- 5** To continue setting other items, repeat steps 3 and 4.

(Continued)

6 To end menu operations, turn the DISPLAY switch to ON.

The menu disappears from the viewfinder screen, and the display indicating the current status of the camcorder appears along the top and bottom of the viewfinder screen.

4-8-8 Setting the D5600K Mode, Assignable Switches and PB VIDEO

4

Use the OTHERS page of the OPERATION menu to turn on the gain amplifier (providing an electrical equivalent of 5600K), to assign the function of the assignable switches 1 and 2 placed on the setup menu operating section and to select the video signals during playback.

1 Set the DISPLAY switch to MENU.

2 Turn the MIC/MENU knob until the OTHERS page appears, and push the MIC/MENU knob.

The OTHERS page appears.

The current setting of an item appears to the right of the item.

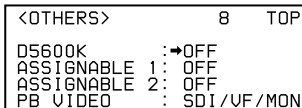

```
<OTHERS>      8  TOP
D5600K          :→OFF
ASSIGNABLE 1   : OFF
ASSIGNABLE 2   : OFF
PB VIDEO       : SDI/VF/MON
```

Item	Content
D5600K	Turns the D5600K gain amplifier on and off.
ASSIGNABLE 1	Assigns the function (OFF, D 12 dB, D 24 dB, VTR S/S, LENS RET or RETURN) to the assignable 1 switch.
ASSIGNABLE 2	Assigns the function (OFF, D 12 dB, D 24 dB, VTR S/S, LENS RET or RETURN) to the assignable 2 switch.
PB VIDEO	SDI/VF/MON: Outputs recorded video signals to the viewfinder, MONITOR OUT connector and the HD SDI OUT connector. ^{a)} SDI ONLY: Outputs the camera image to the viewfinder and the MONITOR OUT connector, and the recorded video signals to the HD SDI OUT connector ^{a)} .

- a) This HD SDI OUT connector is standard on the HDCA-901 Camera Adaptor (not supplied).

- 3** Turn the MIC/MENU knob to move the arrow (→) to the item you want to set, and push the MIC/MENU knob.

The arrow (→) changes to a question mark (?).

- 4** Turn the MIC/MENU knob to change the desired setting, and push the MIC/MENU knob.

(Continued)

To turn the D5600K gain amplifier on or off:

When color temperature is high, signal to noise ratio of blue component becomes better as compared to the correction with the CC filter. And also, when lighting is dark and color temperature is high, it is possible to correct color temperature with sensitivity higher than CC filter.

Note

When you change the setting of the D5600K gain amplifier, it is necessary to perform automatic white balance adjustment.

For details, see “4-1-2 Adjusting the White Balance” on page 4-5.

To assign the function to the assignable switches:

Function	Content
OFF	Does not assign the function to the assignable switch.
D 12 dB	Assigns the ON/OFF function for additional + 12 dB gain in the digital picture element to the assignable switch.
D 24 dB	Assigns the ON/OFF function for additional + 24 dB gain in the digital picture element to the assignable switch.
VTR S/S	Assigns the VTR S/S (start/stop) function to the assignable switch.
LENS RET	Assigns the same function as that of the RET switch on the lens to the assignable switch.
RETURN	Assigns the ON/OFF function to display the image of the return video signal on the viewfinder to the assignable switch.

PB VIDEO settings:

Select SDI ONLY to see the camera image on the viewfinder and the monitor connected to the MONITOR OUT connector even during playing back. You can see the image seen by the camera all the time and change the menu setting any time you want. To see a

recorded video signal, you have to attach an HDCA-901 Camera Adaptor (not supplied). Since recorded HD SDI video signals are output to the HD SDI OUT connector of the HDCA-901, you can see a recorded video signal on the monitor connected to the HD SDI OUT connector.

At the SDI/VF/MON default setting, the recorded video signals are output to the viewfinder, MONITOR OUT connector and HD SDI OUT connector during play back.

The question mark (?) changes back to the arrow (→) to confirm the setting.

5 To continue setting other items, repeat steps 3 and 4.

6 To end menu operations, turn the DISPLAY switch to ON.

The menu disappears from the viewfinder screen, and the display indicating the current status of the camcorder appears along the top and bottom of the viewfinder screen.

4-8-9 Saving or Reading Setup Data to or from the Memory Stick

Use the OPERATOR FILE page of the OPERATION menu to save the setup data of OPERATION menu pages 1 to 8 to or read the data from a memory stick.

Note

Settings for OVERRIDE on the AUTO IRIS page and D5600K on the OTHERS page are not saved.

For detailed information on operations on the OPERATOR FILE page, see “4-11-2 Using Data on the Memory Stick” on page 4-93.

(Continued)

This section gives a brief explanation about the OPERATOR FILE page.

Item	Content
READ (MS → CAM)	Reads data from the memory stick.
WRITE (CAM → MS)	Writes data to the memory stick.
PRESET	Returns data to the preset status that was set by using the file menu.
FILE ID	Sets a file ID consisting of up to 14 alphanumeric characters, symbols, and spaces.
CAM CODE	Displays the camera model code that is saved on the memory stick.
DATE	Displays the date when the data was saved.

4-8-10 Selecting the Lens File

Use the Lens File page of the OPERATION menu to change the lens file according to the lens in use.

- 1 Set the DISPLAY switch to MENU.
- 2 Turn the MIC/MENU knob until the LENS FILE page appears, and push the MIC/MENU knob.

The LENS FILE page appears.

The name and the f-stop (iris setting) of the lens currently selected appears.

```
<LENS FILE>          10  TOP
FILE:→ 1
HA14×8
F2.0
IMAGE INVERT:  --
```

Note

The IMAGE INVERT item is displayed only when the HKDW-902 Image Invertor Board is mounted.

- 3 Turn the MIC/MENU knob to move the arrow (→) to FILE on the LENS FILE page, and push the MIC/MENU knob.

The arrow (→) changes to a question mark (?).

- 4 Turn the MIC/MENU knob to display the name of the lens in use (in this case, the lens file number corresponding the name of the lens displayed appears), then push the MIC/MENU knob.

The question mark (?) changes back to the arrow (→) and the name and the iris setting of the selected lens file.

- 5 To end menu operations, turn the DISPLAY switch to ON.

The menu disappears from the viewfinder screen, and the display indicating the current status of the camcorder appears along the top and bottom of the viewfinder screen.

4-9 Paint Menu

The PAINT menu contains various detail adjustment items such as white clipping. It also enables you to save up to 100 sets of detail-adjusted data customized to certain shooting scenes (SCENE FILE page) (5 scene files for each group × 20 groups) to a Memory Stick.

For information about how to set items, see Section 4-5-1 “Basic Use of the Setup Menu” (page 4-31).

For detailed information on the Paint Menu, refer to the Maintenance Manual.

4

Selecting the PAINT menu

- 1 While pushing the MIC/MENU knob, change the DISPLAY switch from OFF to MENU.

The TOP menu screen will appear.

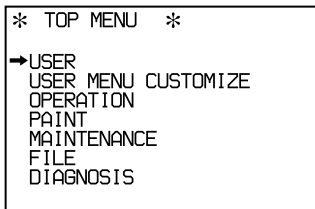

- 2 Turn the MIC/MENU knob to move the arrow (→) until it points to PAINT.
- 3 Push the MIC/MENU knob.

The PAINT menu screen will appear.

To return to the TOP menu from the PAINT menu

The following two methods are available:

- Point the arrow (→) to TOP on the right top on each page, then press the MIC/MENU knob.
- Push the MENU switch to the CANCEL side twice.

PAINT menu items

This section introduces pages of the PAINT menu and items contained on each page.

To reset all current detailed-adjusted settings and switch settings to the reference file data

You can clear all current detailed-adjusted settings and switch settings, and returning the settings to the standard settings (saved in the reference file). Select STANDARD on the SCENE FILE page of the PAINT menu. The message “RECALLED” is being displayed for about 3 seconds. If you do not any operation while this message is being displayed, all current detailed-adjusted settings and switch settings and returns the setting to the standard settings.

If you push the MIC/MENU knob while this message is being displayed, operation is cancelled, and all current detailed-adjusted settings and switch settings are remained as they are.

For details, refer to the Maintenance Manual.

To reset a specific item in the PAINT menu to its standard (factory) setting on each page

Rotate the MIC/MENU knob to move the arrow (→) to the item and hold down the MIC/MENU knob for three seconds to reset the selected item to its standard setting. This function operates for items that require a precise value to be entered.

You can change the standard settings by saving the changed settings in the reference file using the FILE menu.

(Continued)

List of the PAINT menu

Page	Item	Setting	Description
SW STATUS	FLARE	ON, OFF	Turns flare correction on or off.
	GAMMA	ON, OFF	Turns gamma correction on or off.
	BLK GAM	ON, OFF	Turns black gamma correction on or off.
	KNEE	ON, OFF	Turns knee correction on or off.
	WHT CLIP	ON, OFF	Turns white clipping on or off.
	DETAIL	ON, OFF	Turns the detail signal on or off.
	LVL DEP	ON, OFF	Turns the level depend function of the detail signal on or off.
	SKIN DTL	ON, OFF	Turns the skin detail on or off.
	MATRIX	ON, OFF	Turns linear matrix correction on or off.

Page	Item	Setting	Description
VIDEO LEVEL	WHITE	-99~0~99	Adjusts the white level of R, G, and B
	BLACK	-99~0~99	Adjusts the R, G, B, and master black level.
	FLARE	-99~0~99	Adjusts the R, G, B, and master flare level.
	GAMMA	-99~0~99	Adjusts the R, G, B, and master gamma correction curve.
	V MOD	-99~0~99	Adjusts the R, G, B, and master V modulation shading.
	FLARE	ON, OFF	Turns the flare correction circuit on or off.
	V MOD	ON, OFF	Turns the V modulation shading on or off.
	TEST	1, 2, OFF	Selects the test signal. 1: Outputs the analog test signal. 2: Outputs the digital test signal. OFF: Does not output any test signal.

(Continued)

Page	Item	Setting	Description
GAMMA	LEVEL	-99~0~99	Sets the R, G, B, and master gamma correction curve.
	COARSE	0.40, 0.45, 0.50	Sets the master gamma correction curve in terms of individual steps.
	TABLE	STANDARD ^{a)} 1, 2, 3, 4, 5, 6 USER ^{b)} 1, 2, 3, 4, 5	Selects the gamma table.
	GAMMA	ON, OFF	Turns the gamma correction function on or off.
	TEST	1, 2, OFF	Selects the test signal. 1: Outputs the analog test signal. 2: Outputs the digital test signal. OFF: Does not output any test signal.

a) STANDARD

- 1: INTIAL GAIN 3.5 (equivalent to ENG camcorder)
- 2: INTIAL GAIN 4.0 LOW (equivalent to EFP camera)
- 3: INTIAL GAIN 4.0 HIGH (equivalent to EFP camera)
- 4: INTIAL GAIN 4.0 (equivalent to SMPT-240M)
- 5: INTIAL GAIN 4.5 (equivalent to ITU-709)
- 6: INTIAL GAIN 5.0

b) USER

1 to 5: Selects the user gamma table stored in the camcorder.

About the user gamma function

You can create the desired gamma table using a personal computer on which special software has been installed and load this table into your camcorder via a Memory Stick.

When a user gamma table is selected, gamma (LEVEL, COARSE or ON/OFF) and knee (POINT, SLOPE, ON/OFF or AUTO KNEE) or both may become disabled. This is because the gamma and knee are compulsorily fixed when creating the gamma curve.

Page	Item	Setting	Description
BLK GAMMA	RGB LEVEL	-99~0~99	Adjusts the R, G, B, and master black gamma.
	RGB RANGE	15, 25, 35, 50%	Sets the upper limit of the video level which the RGB black gamma affects.
		ON, OFF	Turns the RGB black gamma correction function on or off.
	Y LEVEL	-99~0~99	Adjusts the Y black gamma to adjust the contrast without changing the chroma phase of the dark part.
	Y RANGE	15, 25, 35, 50%	Sets the upper limit of the video level which the Y black gamma affects.
		ON, OFF	Turns the Y black gamma correction function on or off.
	TEST	1, 2, OFF	1: Outputs the analog test signal.
			2: Outputs the digital test signal. OFF: Does not output any test signal.

Page	Item	Setting	Description
SATURATION	SATURATION	-99~99	Sets the saturation choosing between "black and white" (-99) or "standard" (0).
		ON, OFF	Turns the saturation function on or off.
	LOW KEY SAT	-99~0~99	Sets the lower limit of the video level which the low key saturation affects.
		ON, OFF	Turns the low key saturation function on or off.

(Continued)

Page	Item	Setting	Description
KNEE	POINT R,G,B,M	-99~0~99	Sets the R, G, B, and master knee point level.
	SLOPE R,G,B,M	-99~0~99	Sets the R, G, B, and master knee slope level.
	WHT R,G,B,M	-99~0~99	Sets the R, G, B, and master of the white clipping level.
	KNEE SAT LEVEL	-99~0~99	Sets the knee saturation level.
	KNEE	ON,OFF	Turns the knee correction circuit on or off.
	KEY SAT	ON, OFF	Turns the knee saturation function on or off.
	WHT CLIP	ON, OFF	Turns the white clipping function on or off.
	TEST	1, 2, OFF	Selects the test signal. 1: Outputs the analog test signal. 2: Outputs the digital test signal . OFF: Does not output any test signal.

Page	Item	Setting	Description
DETAIL 1	LEVEL	-99~0~99	Sets the general level of the detail signal.
	LIMITER M/WHT/BLK	-99~0~99	Sets the detail limiter.
	CRISP	-99~0~99	Sets the crispening level.
	H V RATIO	-99~0~99	Sets the level of the V detail signal.
	FREQ	-99~0~99	Sets the frequency of the H signal.
	LVL DEP	-99~0~99	Sets the level depend.
	DETAIL	ON, OFF	Turns the detail correction function on or off.
	LVL DEP	ON, OFF	Turns the level depend function on or off.
	FINE DTL	-99~0~99	Sets the level of the fine detail signal.
	ON, OFF	Turns the fine detail function on or off.	
DETAIL 2	KNEE	-99~0~99	Sets the knee aperture level .
	APERTURE	ON, OFF	Turns the knee aperture function on or off.

(Continued)

Page	Item	Setting	Description	
SKIN DETAIL	SKIN DTL	ON, OFF	Turns on or off the skin-tone detail function .	
	SKIN GATE	ON, OFF	Turn the zebra indication of the skin tone detail portion on or off.	
	CH SW	ON, OFF	Turns each channel of the skin detail function on or off. Channel 1 is fixed to ON.	
	GATE	ON, OFF	Turns each channel of the skin gate function on or off. Any one of channels is set to on.	
	PHASE	AUTO		Sets automatically the region of each channel the skin detail function affects.
		0~359°		Adjusts the center phase of the hue being processed by the skin-tone detail function to each channel.
	WIDTH	0~90°	Adjusts the width of the hue being processed by the skin- tone detail function to each channel..	
	SAT	-99~0~99	Adjusts the saturation level of the hue being processed by the skin-tone detail function to each channel.	
LEVEL	-99~0~99	Sets the skin tone detail amount to each channel.		

Page	Item	Setting	Description
USER MATRIX	R-G, R-B	-99~0~99	Sets arbitrary R-G or R-B user-set matrix coefficients.
	G-R, G-B	-99~0~99	Sets arbitrary G-R or G-B user-set matrix coefficients.
	B-R, B-G	-99~0~99	Sets arbitrary B-R or B-G user-set matrix coefficients.
	MATRIX	ON, OFF	Turns the linear matrix correction function on or off.
	PRESET ^{a)}	ON, OFF	Turns the preset matrix on or off.
		SMPTE-240M ITU-709 SMPTE-WIDE NTSC EBU ITU-601	Selects the preset matrix.
	USER MATRIX ^{a)}	ON, OFF	Turns the user matrix correction function on or off.
	MULTI MATRIX ^{a)}	ON, OFF	Turns the multi matrix correction function on or off.

a) You cannot perform the setting when the MATRIX is set to OFF.

(Continued)

Page	Item	Setting	Description
MULTI MATRIX	PHASE	2, 23, 45, 68, 90, 113, 135, 158, 180, 203, 225, 248, 270, 293, 315, 338	Sets the region the multi matrix correction function can be changed. (sixteen-axis mode)
	HUE	-99~0~99	Adjusts the color phase the multi matrix correction function affects in every sixteen-axis mode.
	SAT	-99~0~99	Adjusts the saturation level the multi matrix correction function affects in every sixteen-axis mode.
	ALL CLEAR	Push the MIC/MENU knob.	Clears the HUE and SAT values in each phase to 0.
	AUTO DET	Push the MIC/MENU knob.	Automatic color detection function. Detects the color axis by focusing on a subject when you center that subject in the detection gate and push the MIC/MENU knob.
	MATRIX	ON, OFF	Turns the linear matrix correction function on or off.
	PRESET	ON, OFF	Turns the preset matrix on or off.
		SMPTE-240M ITU-709 SMPTE-WIDE NTSC EBU, ITU-609	Selects the preset matrix.
	USER MATRIX ^{a)}	ON, OFF	Turns the user matrix correction function on or off.
	MULTI MATRIX ^{a)}	ON, OFF	Turns the multi matrix correction function on or off.

a) You cannot perform the setting when the MATRIX is set to OFF.

Page	Item	Setting	Description
SHUTTER	SHUTTER/ ECS	ON, OFF	Turns SHUTTER or ECS to ON or OFF.
		1/100 to 1/2000 ^{a)} , ECS	When SHUTTER/ECS is set to ON, selects the shutter speed or ECS.
	ECS FREQ	30 to 4300 Hz ^{a)}	When ECS is selected, sets the ECS frequency.
	S-EVS	ON, OFF	Turns S-EVS mode to ON or OFF.
		0 to 100%	When S-EVS is set to ON, sets the S-EVS vertical resolution.

- a) These are the shutter speed and ECS frequency in the case where 60 I or 59.94 I format is selected in the MULT FORMAT page of the MAINTENANCE menu. When another format is selected, the shutter speed and ECS frequency are as follows.

Shutter speed

60I (59.94I): 1/100, 1/125, 1/250, 1/500, 1/1000, 1/2000 (sec.)

50I: 1/60, 1/125, 1/250, 1/500, 1/1000, 1/2000 (sec.)

30PsF (29.97PsF): 1/40, 1/50, 1/60, 1/120, 1/125, 1/250, 1/500, 1/1000 (sec.)

25PsF: 1/33, 1/50, 1/60, 1/100, 1/125, 1/250, 1/500, 1/1000 (sec.)

24PsF (23.98PsF): 1/32, 1/48, 1/50, 1/60, 1/96, 1/125, 1/250, 1/500, 1/1000 (sec.)

ECS frequency

60I (59.94I): 30.0 to 4300 Hz

50I: 25.0 to 4700 Hz

30PsF (29.97PsF): 30.0 to 2700 Hz

25PsF: 25.0 to 2300 Hz

24PsF (23.98PsF): 24.0 to 2200 Hz

(Continued)

Page	Item	Setting	Description
SCENE FILE	1		Saves and restores a scene file (detail-adjusted data customized to certain shooting scenes).
	2		
	3		
	4		
	5		
	FILE STORE		
	STANDARD		Clears all current detail-adjusted settings and switch settings and returns the settings to the reference file data.
	READ (MS → CAM)		Reads five scene files saved in a Memory Stick belonging to the group number selected using the GP item into the memory of the camcorder.
	GP	1 to 20	Selects the group number of the scene files to be written to or read from a Memory Stick. (Each group has five scene files.) ^{a)}
	WRITE (CAM → MS)		Writes five scene files saved in the memory of the camcorder into a Memory Stick with the group number selected using the GP item.
	FILE ID		Writes comments to the scene files to be saved in the memory stick.
	CAM CODE		Displays the name of the model of the file created.
DATE		Displays the date when the file was created.	

a) You can save up to 20 groups (five scene files are saved in one group), that is, 100 scene files, in a Memory Stick. Scene files are written or read in units of a group.

4-10 Maintenance Menu

The MAINTENANCE menu contains items for performing camera maintenance operations such as changing the system or infrequently used paint item.

This section gives lists of items that can be performed on the MAINTENANCE menu.

For detailed information about how to set items, refer to the maintenance manual.

Selecting the MAINTENANCE menu

- 1** While pushing the MIC/MENU knob, change the DISPLAY switch from OFF to MENU.

The TOP menu screen will appear.

- 2** Turn the MIC/MENU knob to move the arrow (→) until it points to MAINTENANCE.

- 3** Push the MIC/MENU knob.

The MAINTENANCE menu screen will appear.

To return to the TOP menu from the PAINT menu

The following two methods are available:

- Point the arrow (→) to TOP on the right top on each page, then press the MIC/MENU knob.
- Push the MENU switch to the CANCEL side twice.

(Continued)

MAINTENANCE menu items

Page	Item	Setting
AUTO SETUP	AUTO BLACK	
	AUTO WHITE	
	AUTO LEVEL	
	TEST	ON, OFF

Page	Item	Setting
WHITE SHADING	V SAW	R/G/B -99~0~99
	V PARA	R/G/B -99~0~99
	H SAW	R/G/B -99~0~99
	H PARA	R/G/B -99~0~99
	WHITE	R/G/B -99~0~99
	V MODE	R/G/B/M -99~0~99 ON, OFF

Page	Item	Setting
BLACK SHADING	V SAW	R/G/B -99~0~99
	V PARA	R/G/B -99~0~99
	H SAW	R/G/B -99~0~99
	H PARA	R/G/B -99~0~99
	BLK SET	R/G/B -99~0~99
	BLACK	R/G/B/M -99~0~99
	MASTER GAIN	-3, 0, 3, 6, 12, 18 dB

Page	Item	Setting
OHB MATRIX	PHASE	0, 23, 45, 68, 90, 113, 135, 158, 180, 203, 225, 248, 270, 293, 315, 338
	HUE	-99~0~99
	SAT	-99~0~99
		ALL CLEAR (Clears paint values of HUE and SAT for each PHASE to 0.)
	MATRIX	ON, OFF
	OHB MATRIX	ON, OFF

Page	Item	Setting
AUTO IRIS	WINDOW	1, 2, 3, 4, 5, 6
	OVERRIDE	-99~0~99
	IRIS LEVEL	-99~0~99
	APL RATIO	-99~75~99
	IRIS GAIN	-99~0~99

Page	Item	Setting
CAM ID/DATE	CAM ID	14 letters
	DATE/TIME	Date/time

(Continued)

Page	Item	Setting
MULT FORMAT	CURRENT	Currently selected format (only display)
	NEXT	New format ^{a)} 60I ,59.94I, 50I, 30PsF, 29.97PsF, 25PsF, 24PsF, 23.98PsF

- a) Select the desired format in the NEXT column. In the CURRENT column the currently selected format is displayed. Newly selected format is executed after the power is turned off and on. It is then displayed in the CURRENT column on this page.

Page	Item	Setting
VTR SETUP	FF/REW AUDIO	EE, CUE
	PB AUDIO CH	1/2, 3/4
	AU REC CH 3/4	AUTO, 1/2 CH, MUTE
	AU REC 1KHz	MUTE, 0 dB, -20 dB
	AU EMPHASIS	ON, OFF
	TC OUT	TCG/PB, TCG
	CTL TIMER	24H, \pm 10H
	REAL TIME	AUTO, MANU

Page	Item	Setting
BATT ALARM	BATT	
	TYPE	LITHIUM, DIGITAL, OTHERS 1, OTHERS 2, AC ADP
	BEFORE END	Alarm voltage 11.0 V to 17 V (ineffective when AC ADP is selected)
	END	END (Shutdown) voltage 11.0 V to 17 V (ineffective when AC ADP is selected)
	DC IN	
	TYPE	LITHIUM, DIGITAL, OTHERS 1, OTHERS 2, AC ADP
	BEFORE END	Alarm voltage 11.0 V to 17 V (ineffective when AC ADP is selected)
	END	END (Shutdown) voltage 11.0 V to 17 V (ineffective when AC ADP is selected)

Page	Item	Setting
OTHERS 1	H PHASE	-3072~0~1023
	MONITOR OUT	
	Y	-30~0~30
	Pb/Pr	-30~0~30

(Continued)

Page	Item	Setting
OTHERS 2	FAN MODE	AUTO 1, AUTO 2, MIN, MAX
	MENU RESUME	OPE MENU, ALL, OFF
	DATA TYPE	1, 2, 3, 4, 5, 6 ^{a)}
	WHITE MEMORY	8, 2
	COLOR BAR	FULL 16:9, SMPTE 16:9, FULL 4:3, SMPTE 4:3

a) Display type of the date

- 1: Y/Mn/D (Year/Month/Day) (Month is expressed in figures)
- 2: Mn/D (Month/Day) (Month is expressed in figures)
- 3: D/M/Y (Day/Month/Year)
- 4: D/M (Day/Month)
- 5: M/D/Y (Month/Day/Year)
- 6: M/D (Month/Day)

4-11 Using the Memory Stick

The camcorder is equipped with a Memory Stick drive, which enables you to save contents of the settings for OPERATOR, SCENE and REFERENCE files respectively. You can recreate suitable setup condition rapidly using data in the Memory Stick.

4-11-1 Handling the Memory Stick

The Memory Stick can be inserted or removed from the camcorder with the power turned on or off.

Removing the Memory Stick

- 1 Open the cover of the Memory Stick compartment.
- 2 Push the eject button after confirming that the access indicator of the Memory Stick is not lit.

The Memory Stick pops out.

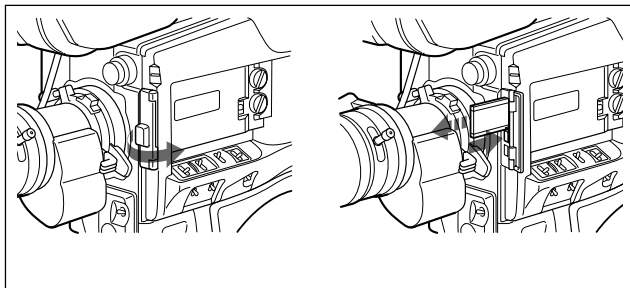

Removing the Memory Stick

(Continued)

Note

Do not remove the Memory Stick while the access indicator is lit, the camcorder is reading or writing data on the Memory Stick.

Inserting the Memory Stick

Open the cover of the Memory Stick compartment.

Hold the Memory Stick with the notch facing upward and the arrow facing toward you, and insert the Memory Stick into the Memory Stick insertion slot until it clicks into place.

Then, close the cover.

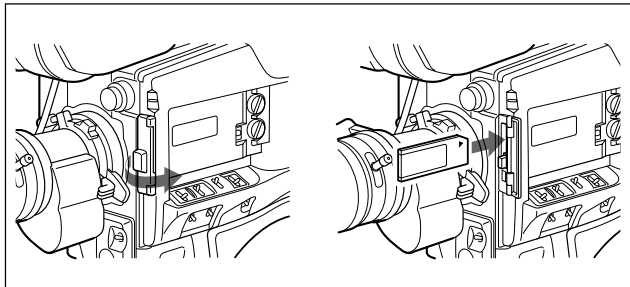

Inserting the Memory Stick

Notes

- If it does not fit into the slot properly or if there is some resistance when you insert it, the Memory Stick may be turned around or upside down. Do not force the Memory Stick into the slot. Confirm the direction of the notch and arrow on the Memory Stick before inserting the Memory Stick, and then try inserting it again.
- You may not be able to remove or insert the Memory Stick because the extender of the lens stands in the way. In such a case, remove the lens, then insert or remove the Memory Stick.

Avoid on using and storing the Memory Stick

- Avoid touching the connector of the Memory Stick or contacting it with a metal object.
- When attaching a label to the Memory Stick, use only the label supplied for the Memory Stick.
- Do not drop, bend, or submit the Memory Stick to external shock.
- Do not disassemble or modify the Memory Stick.
- Avoid getting liquids on the Memory Stick.
- Avoid using or storing the Memory Stick in a location subject to:
 - extremely high temperature such as the hot inside of a car or the outdoors exposed to a burning sun, or a place near a heater.
 - direct sunlight
 - high humidity
 - excessive dust
- When storing and carrying the Memory Stick, keep it in its original case to ensure protection of important data.
- When carrying the camcorder with the Memory Stick inserted, close the cover.
- Avoid removing the Memory Stick from the insertion slot while the access indicator is lit.
- Do not format the Memory Stick using a PC.

4-11-2 Using Data on the Memory Stick — in Case of an OPERATOR File

The operations of saving data to the Memory Stick and reading the saved data from the Memory Stick are done from the OPERATOR FILE page of the OPERATION menu.

For detailed information on how to write/read the data into/from the Memory Stick, refer to the Maintenance Manual.

Writing data to the Memory Stick

Following the procedure below.

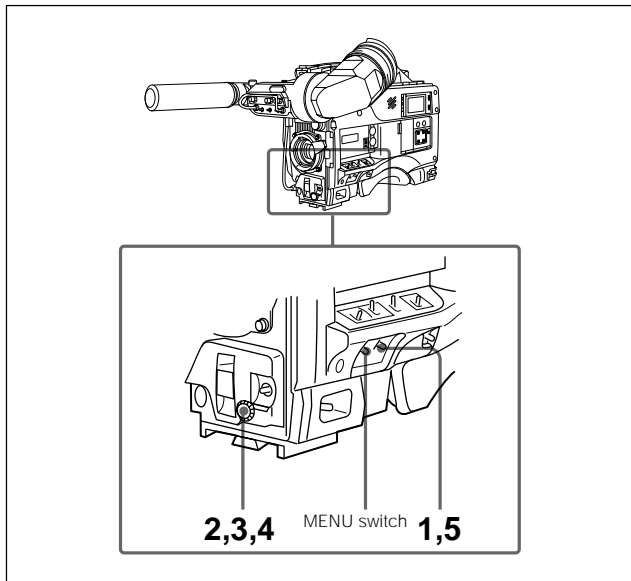

Writing data to the Memory Stick

- 1 Set the DISPLAY switch to MENU.

The page that was on the screen when the last menu operation ended appears on the viewfinder screen. (When this MENU is first used, the lowest page number of the previously selected will appear.)

- 2** Turn the MIC/MENU knob until the OPERATOR FILE page appears, and then push the MIC/MENU knob.

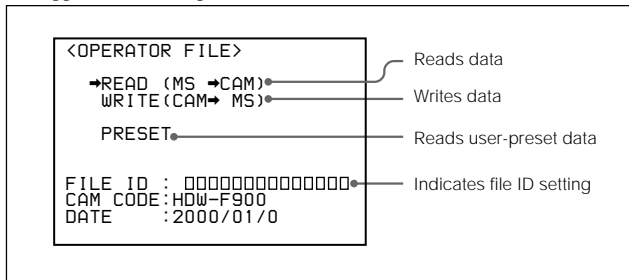

OPERATOR FILE page

- 3** Move the arrow (→) by turning the MIC/MENU knob until it points to WRITE (CAM → MS), and push the MIC/MENU knob.

“WRITE OK?” appears. If no Memory Stick has been inserted, the message “NO MEMORY STICK!” will appear. Insert a Memory Stick.

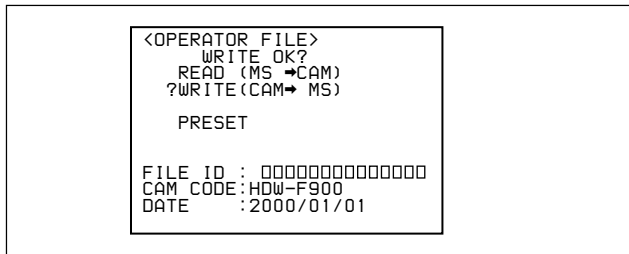

(Continued)

-
- To end the writing of data, push the MENU switch to CANCEL.
 - To continue the writing of data, go to step 4.

4 Push the MIC/MENU knob.

The setting data stored in the camcorder is written to the Memory Stick.

When the writing is completed, the message “COMPLETE” appears.

5 To end the menu operations, set the DISPLAY switch to ON.

The setup menu disappears from the viewfinder screen and the displays indicating the current status of the camcorder appear along the top and bottom of the viewfinder.

To read user-preset data

Current settings of items related to the OPERATION menu can be saved as user preset data. You can read user-preset data by selecting PRESET on the OPERATOR FILE page.

The current settings related to the OPERATION menu is replaced with the user-preset data.

For detailed information on how to save the settings as user-preset data, refer to the Maintenance Manual.

Protecting saved data

To prevent accidental erasure of important setup data, use the write protect switch on the Memory Stick.

Slide the switch right to the write protect position. It is now impossible to write or delete data on the Memory Stick.

If you set the write protect switch to the write protect position, in step 4 when pushing the MIC/MENU knob in the previous section (page 4-87), “MEMORY STICK LOCKED!” appears and the already saved data will not be overwritten.

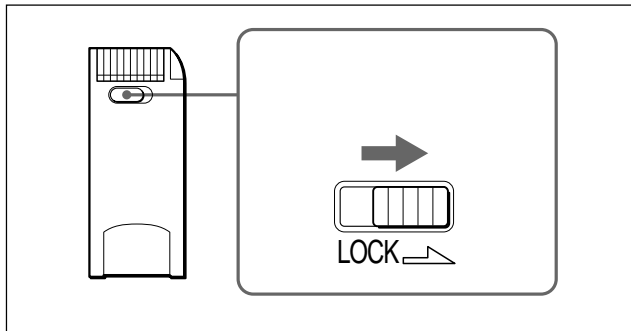

Write protect switch on the Memory Stick

If data cannot be written

If one of the following error messages appears when you push the MIC/MENU knob in step **4** of the procedure in the previous section (page 4-87), then the data was not written.

Data write error messages

Error message	Reason	Action
NO MEMORY STICK	No Memory Stick is inserted.	Insert or reinsert the Memory Stick.
MEMORY STICK LOCKED	The write protect switch on the Memory Stick is set to the write protect position.	Set the write protect switch to the write enable position.
MEMORY STICK ERROR (flashing)	Circuit or Memory Stick fault.	Check the circuitry, or replace the Memory Stick .

Reading saved data from a Memory Stick

Follow the procedure below.

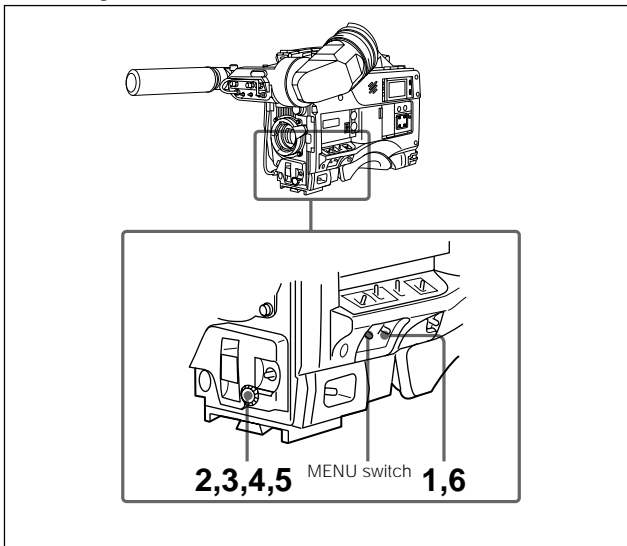

Reading saved data from a Memory Stick

- 1 Set the DISPLAY switch to MENU.

The page that was on the screen when the last menu operation ended appears on the viewfinder screen. (When this menu is first used, the lowest-numbered one of the currently selected pages appears.)

(Continued)

- 2** Turn the MIC/MENU knob until the OPERATOR FILE page appears, and then push the MIC/MENU knob.

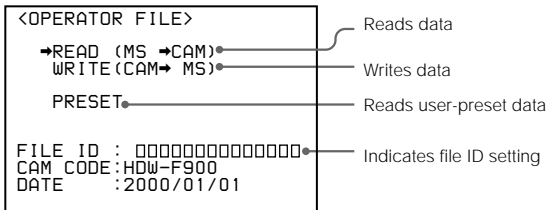

OPERATOR FILE page (factory settings)

- 3** Move the arrow (→) by turning the MIC/MENU knob until it points to READ (MS → CAM).
- 4** push the MIC/MENU knob.

A message “READ OK?” asking whether or not data is to be read from the Memory Stick appears.

A screenshot of the OPERATOR FILE menu. The menu items are: <OPERATOR FILE>, READ OK?, →READ (MS →CAM), WRITE (CAM→ MS), PRESET, FILE ID : 0000000000000000, CAM CODE: HDW-F900, and DATE : 2000/01/01. The arrow in the READ option now points to the left.

If no Memory Stick is inserted, the message “NO MEMORY STICK!” appears. Insert a Memory Stick.

-
- To end the reading of data, push the MENU switch to CANCEL.
 - To continue the reading of data, go to step 5.

Note

The data read from the Memory Stick overwrite the data stored in the camcorder.

5 Push the MIC/MENU knob.

When the reading is completed, the message “COMPLETE” appears.

6 To end the menu operations, set the DISPLAY switch to ON.

The setup menu disappears from the viewfinder screen and the displays indicating the current status of the camcorder appear along the top and bottom of the viewfinder.

If data cannot be read

If one of the following error messages appears when you push the MIC/MENU knob in step 5, then the data was not read.

Data read error messages

Error message	Reason	Action
NO MEMORY STICK	No Memory Stick is inserted.	Insert or reinsert the Memory Stick.
MEMORY STICK ERROR (flashing)	Circuit or Memory Stick fault.	Recheck, and consult a Sony representative.
FILE ERROR (flashing)	The memory contains data that cannot be read with this camcorder.	Do not try to read data written with another camcorder.

Setting the FILE ID

When data is written to a Memory Stick, it is useful to set a file ID for the Memory Stick to identify it.

When data is saved to a Memory Stick, a file ID is written to the Memory Stick together with the data.

- 1 Turn the MIC/MENU knob until the arrow (→) points to FILE ID on the OPERATOR FILE page.

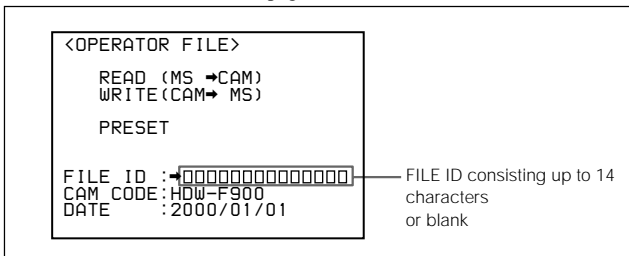

- 2 Push the MIC/MENU knob.

The character table consisting of three lines appears.

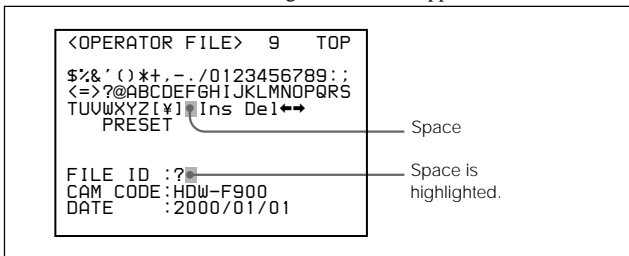

(Continued)

When you set the file ID for the first time, the top position is highlighted.

When the file ID has been set, the top character of the file ID is highlighted.

3 Enter the file ID.

When you set the file ID for the first time, start from step 2.

- ① Press the MIC/MENU knob until the character you wish to change is highlighted.
- Each time you press the MIC/MENU knob, the highlighted character moves to the right one by one.
- Or highlight the ← or → in the character table, then push the MIC/MENU knob. The highlighted character moves to the right or left according to the selected direction each time you push the MIC/MENU knob.

- ② Turn the MIC/MENU knob until the desired character is highlighted in the character table.

Example: To enter S

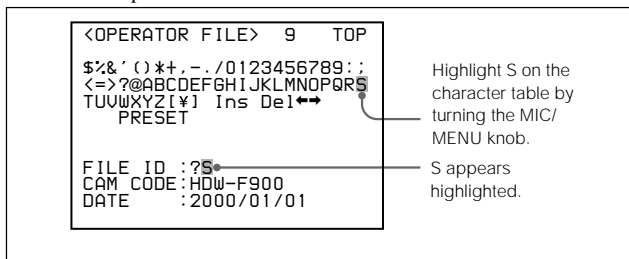

③ Push the MIC/MENU knob.

The character selected in step ② is entered, the cursor moves to the next position and that position is highlighted.

When there are no characters after the entered letter, the next position is a space and the space is selected on the character table. If you want to a space, enter the space in the same way you enter a character.

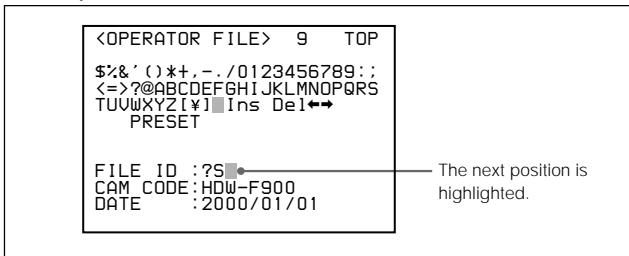

4 Enter the remaining characters by repeating step 3.

By pushing the MIC/MENU knob when the last position of the 14 characters is highlighted, the entered FILE ID is executed and the character table disappears.

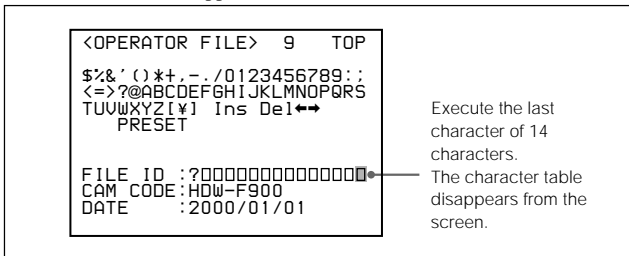

(Continued)

Notes

- When the file ID consists of less than 14 characters, enter spaces in the remaining positions.
- Execute the file ID before saving data in the Memory Stick. Otherwise, the file ID is not saved with the other data.

This file ID is saved in the Memory Stick with another data.

4

To reset the file ID to the original one

Push the MIC/MENU knob to the CANCEL side before you enter the last character (the 14th one), that is while the character table is displayed on the screen.

The entered FILE ID is cancelled, and the original one appears.

To delete entered characters

- 1 Push the MIC/MENU knob until the character to be deleted is highlighted.

Each time you push the MIC/MENU knob, the highlighted character moves to the right one by one.

Or highlight the ← or → in the character table, then press the MIC/MENU knob. The highlighted character moves to the right or left according to the selected direction.

- 2 Turn the MIC/MENU knob until DEL is highlighted on the character table.
- 3 Press the MIC/MENU knob.

The character highlighted in step 1 is deleted and the next character moves up to this position.

To add characters

- 1 Push the MIC/MENU knob until the character located after the position where you want to add a character is highlighted.

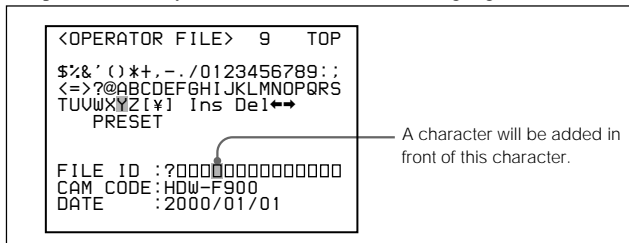

- 2 Turn the MIC/MENU knob until INS is highlighted on the character table.

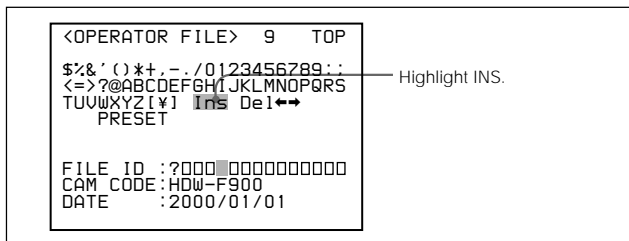

- 3 Press the MIC/MENU knob.

A space is placed and highlighted before the character highlighted in step 1.

Characters after this move down one by one.

Add the desired character at the highlighted position.

5-1 Power Supply

You need to power on the camcorder to adjust the flange focal length and make other adjustments, which are described later.

First, prepare the power supply.

The following power supplies can be used with the camcorder.

- A BP-L60A lithium-ion battery pack
- AC power using AC-550

5-1-1 Using a BP-L60A Battery Pack

When a BP-L60A Battery Pack is used, the camcorder will operate continuously for about 80 minutes. Before use, charge the battery pack with a BC-L100 Battery Charger. It takes about 2.5 hours to charge one BP-L60A.

For more information, refer to the BC-L100 manual.

Note on using the battery pack

A warm battery pack may not be able to be fully recharged.

Attaching the battery pack

- 1 Press the battery pack against the back of the camcorder, aligning the side line of the battery pack with the line on the camcorder.

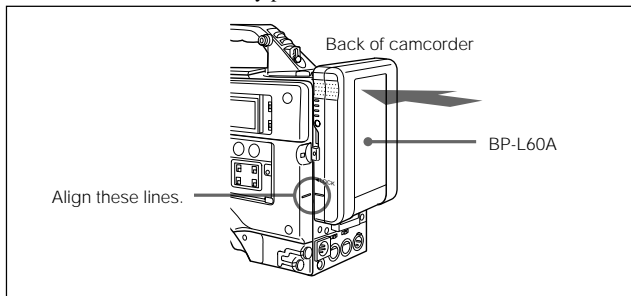

- 2 Slide the battery pack down until its "LOCK" arrow points at the matching line on the camcorder.

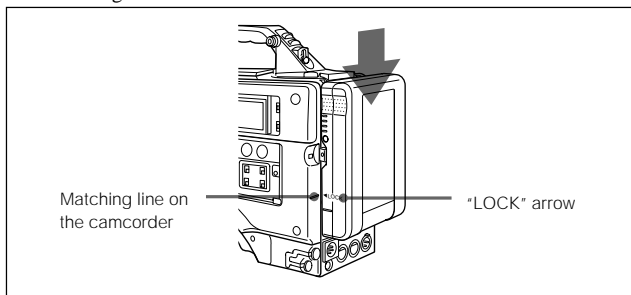

Detaching the battery pack

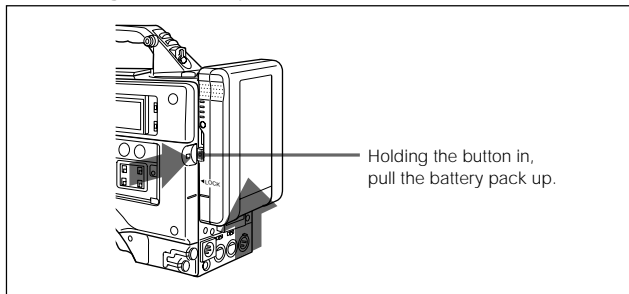

Detaching the battery pack

5-1-2 Avoiding Breaks in Operation Due to Dead Batteries

If you use both an internal battery pack and an external battery connected to the DC IN connector at the same time, you can avoid breaks in operation due to dead batteries.

When the external battery begins to fail and an internal battery pack is also used

Remove the DC output cable from the DC IN connector. The power source will switch to the internal battery pack.

5

When the external battery begins to fail and an internal battery pack is not used

First load the camcorder with a fully charged internal battery pack, then remove the DC output cable of the external battery from the DC IN connector. The power source will switch to the internal battery pack. To use an external battery again, connect a fully charged external battery to the DC IN connector before unloading the internal battery pack. The power source will switch to the external battery.

Continuous operation when operating with only an internal battery pack

First, connect a fully charged external battery to the DC IN connector, then change the internal battery.

Notes

- When an internal battery pack is loaded and an external battery is connected to the DC IN connector, the external battery is always used as the power source.
- There may be some noise on the video signal at the instant the power sources are switched.

5-1-3 Using an AC Adaptor

Connect the camcorder to the AC power supply through the AC-550 AC Adaptor as shown in the following figure, and turn the POWER switch of the AC-550 on.

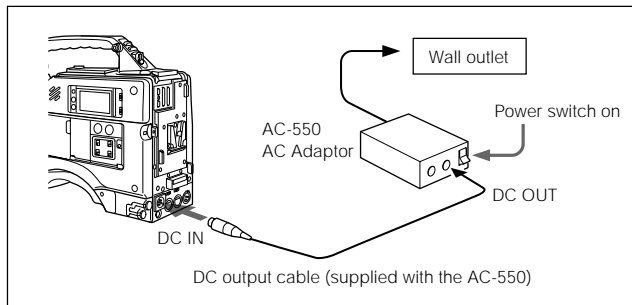

Connecting to an AC power source

5-1-4 Using the Anton Bauer Ultralight System

You can equip the camcorder with a special battery mount that the Anton Bauer Corporation has developed for its Ultralight System.

Ultralight System: By installing this system on the camcorder, you can switch the video light on and off automatically as you start and stop VTR operation, using the VTR START button on the camcorder or the VTR button on the lens.

Contact your Sony representative for more information.

5-2 Adjusting the Viewfinder

For maximum viewing convenience, you can adjust the viewfinder position in the left-right and backward-forward directions.

5-2-1 Adjusting the Viewfinder Position

Adjusting the position to the left or right

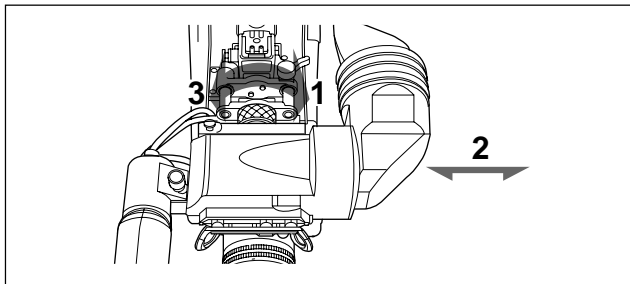

Adjusting the position to the left or right

- 1** Loosen the viewfinder left-right positioning ring.
- 2** Slide the viewfinder to the most convenient position.
- 3** Tighten the viewfinder left-right positioning ring.

Storing the camcorder in the carrying case

Always store the camcorder with the viewfinder moved fully in the direction opposite to the barrel and the viewfinder left-right positioning ring tightened.

Adjusting the position backward or forward

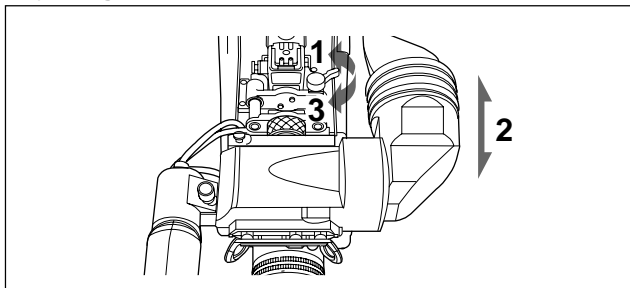

Adjusting the position backward or forward

- 1** Loosen the viewfinder front-rear positioning lever.
- 2** Slide the viewfinder longitudinally to the most convenient position.
- 3** Tighten the viewfinder front-rear positioning lever.

5-2-2 Detaching the Viewfinder

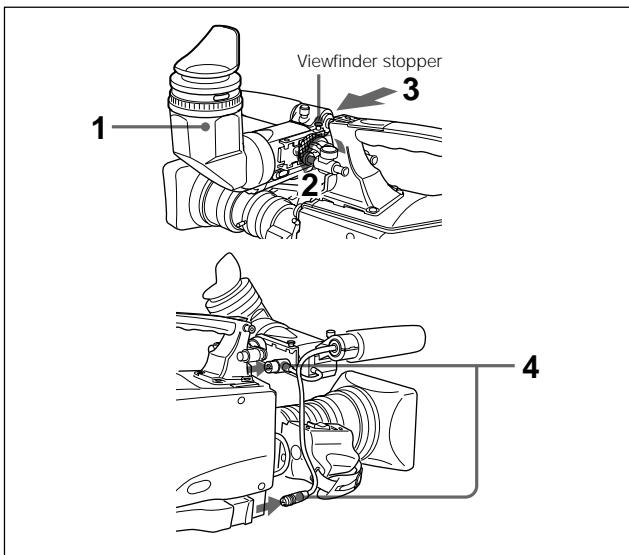

Detaching the viewfinder

- 1** Point the viewfinder barrel up or down.
- 2** Loosen the viewfinder left-right positioning ring.
- 3** Holding the viewfinder stopper up, slide the viewfinder in the direction indicated by the arrow and detach it.

(Continued)

-
- 4** Remove the viewfinder cable and microphone cable from the clamps and disconnect them.

The viewfinder rotation bracket

By fitting a BKW-401 Viewfinder Rotation Bracket (not supplied), you can rotate the viewfinder out of the way so that your right leg does not hit the viewfinder while you are carrying the camcorder.

For more information, refer to the BKW-401 manual.

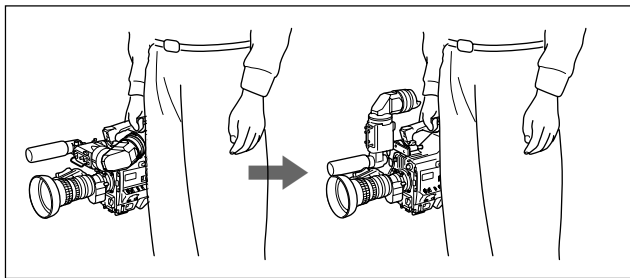

Using the BKW-401 Viewfinder Rotation Bracket

5-3 Mounting the Lens

Follow the procedure below to mount the lens.

For information about using the lens, refer to the lens manual.

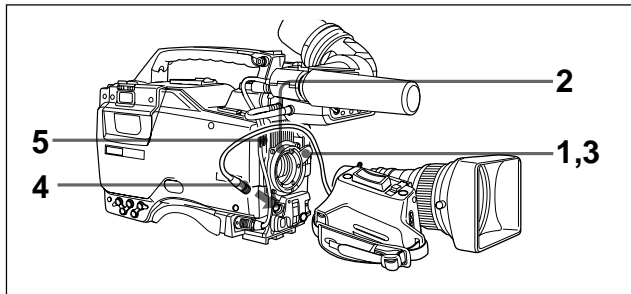

Mounting the lens

- 1** Push the lens locking lever up and remove the lens mount cap from the lens mount.
- 2** Align the center slot in the lens mount with the center pin on the lens, and insert the lens into the mount.
- 3** Holding the lens in place, push the lens locking lever down to mount the lens.
- 4** Connect the lens cable to the LENS connector.
- 5** Secure the lens cable with the cable clamps.

5-4 Adjusting the Flange Focal Length

If the lens does not stay in focus properly as you zoom from telephoto to wide angle, adjust the flange focal length (the distance from the plane of the lens mounting flange to the imaging plane). Make this adjustment after mounting or changing the lens.

Adjusting the flange focal length

The position of the controls for adjusting the flange focal length vary somewhat from lens to lens. Check the identification of the various controls in the lens manual.

5

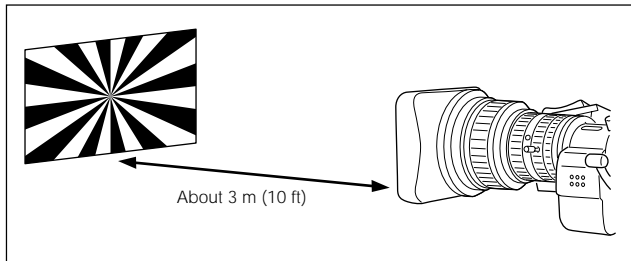

Adjusting the flange focal length

- 1 Set the iris to manual.
- 2 Open the iris. Place the flange focal length adjustment chart about 3 m (10 ft) away from the camera, lit well enough to provide a satisfactory video output level.
- 3 Loosen the fixing screws on the Ff ring (flange focal length adjustment ring).
- 4 Use manual or power zoom to set the lens to telephoto.

-
- 5** Point the camera at the chart by turning the focus ring and focus on it.
 - 6** Set the zoom ring to wide angle.
 - 7** Turn the Ff ring until the chart is in focus, being careful not to disturb the focus ring.
 - 8** Repeat steps **4** to **7** until the chart stays in focus all the way from wide angle to telephoto.
 - 9** Tighten the Ff ring fixing screws.

5-5 Audio Input System

5-5-1 Using the Supplied Microphone

You can use the supplied microphone either detached from the camcorder using the extension cable, or attached to the camcorder.

Using the microphone detached from the camcorder

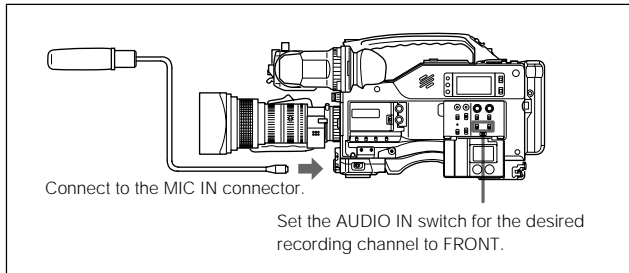

Using the supplied microphone detached from the camcorder

Note

When using the supplied microphone with an extension cable, always use an external power supply type cable.

Using the microphone attached to the camcorder

When the HDVF-20A HD Electronic Viewfinder (not supplied) is used, attach the microphone as follows.

- 1 Loosen the screw and open the microphone holder.

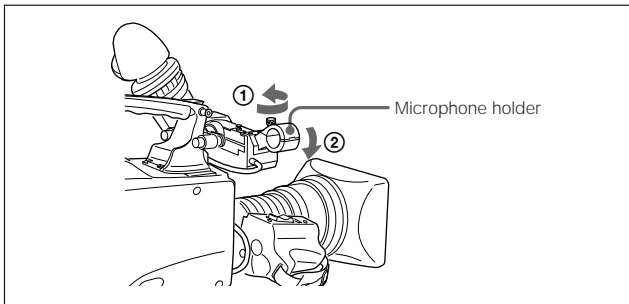

- 2 Place the microphone in the microphone holder.

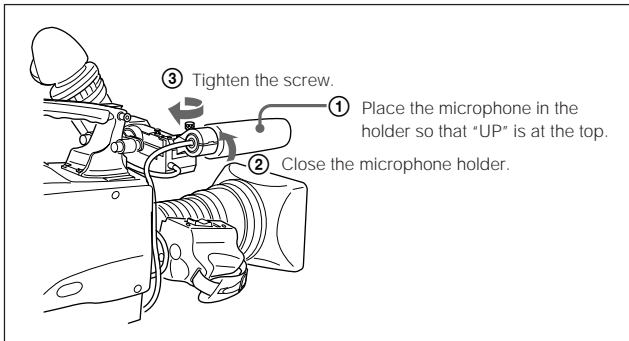

(Continued)

- 3** Plug the microphone cable into the MIC IN connector, and set the AUDIO IN switch for the desired recording channel to FRONT.

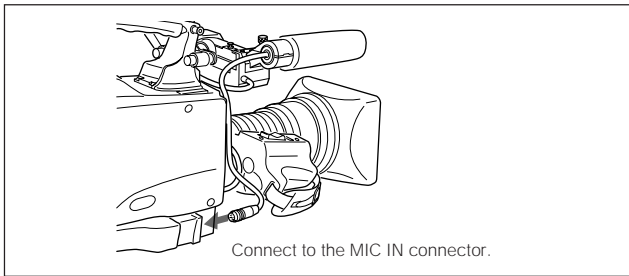

5

When the HDVF-C30W HD Electronic Viewfinder (not supplied) is used

The HDVF-C30W is not equipped with the microphone holder. Attach the CAC-12 Microphone Holder (not supplied) to the camcorder first, then attach the supplied microphone.

For detailed information on how to attach the CAC-12, follow the procedure of steps 2, 3 and 4 described in “Using an external microphone attached to the camcorder” in “5-5-2 Using an External Microphone” on pages 5-19 to 5-20.

5-5-2 Using an External Microphone

You can connect up to two external microphones, using the AUDIO IN CH-1 and CH-2 connectors. When you use an external power supply type microphone, set the LINE/MIC/+48 V ON switch to +48 V ON. If a microphone you use is not the external power supply type, set the LINE/MIC/+48 V ON switch to MIC.

Using a detached external microphone

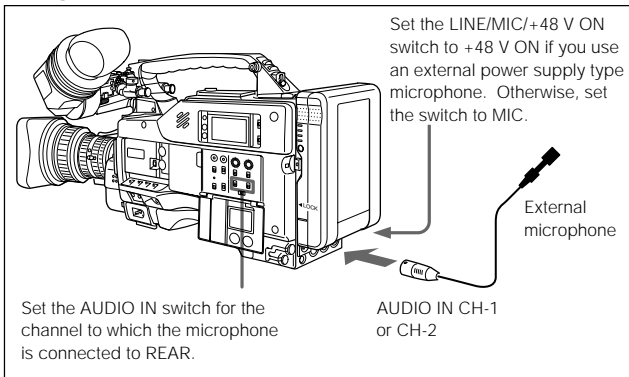

Using a detached external microphone

Using an external microphone attached to the camcorder

You can attach an external microphone to the camcorder by using the CAC-12 Microphone Holder (not supplied). Additionally, by using the CRS-3P Cradle Suspension (not supplied), you can reduce the mechanical vibration noise from the VTR, and can also attach a long microphone. Note, however, that use of the CRS-3P requires a microphone holder (A) (Part No. 3-680-581-01), which is not supplied with the CRS-3P.

The procedure for attaching an external microphone using a CAC-12 and CRS-3P is shown below.

Refer to the microphone holder or cradle suspension manual for more information.

- 1 Assemble the CRS-3P Cradle Suspension and microphone holder (A) (Part No. 3-680-581-01).

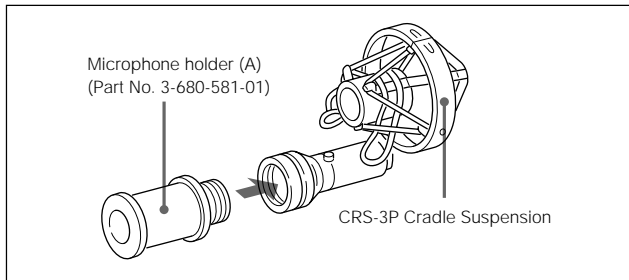

2 Remove the external microphone holder attachment screws.

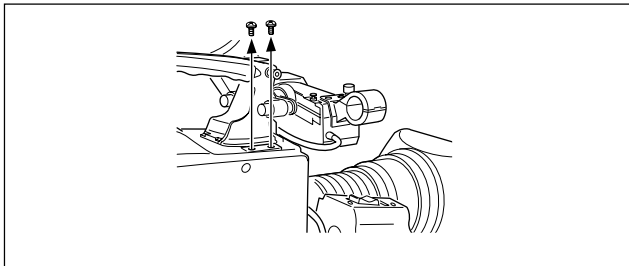

3 Attach the CAC-12 Microphone Holder.

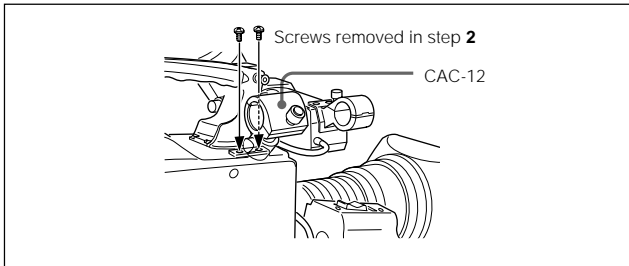

(Continued)

4 Open the CAC-12 and remove the microphone adaptor.

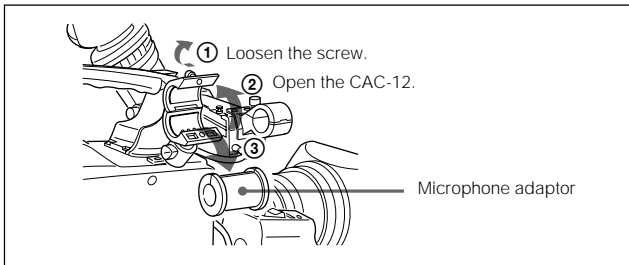

5

5 Mount the assembly from step 1 in the CAC-12.

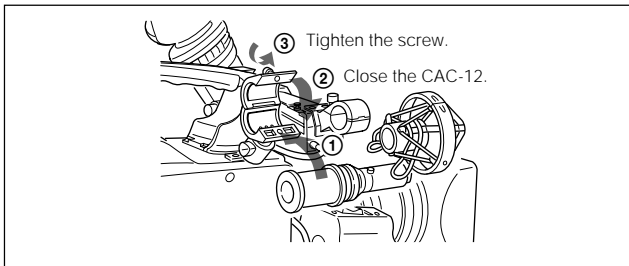

6 Mount the microphone into the cradle suspension.

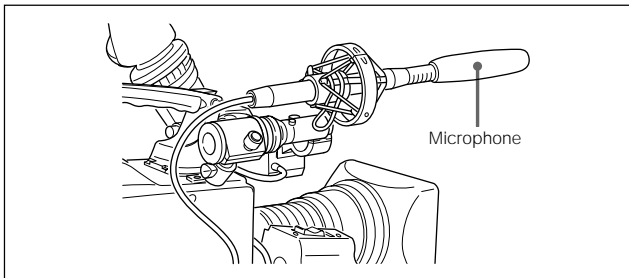

- 7** Connect the microphone cable to the AUDIO IN connector for channel 1 or 2. Set the corresponding AUDIO IN switch to REAR. Set the LINE/MIC/+48V ON switch to +48V ON or MIC in accordance with the type of the microphone power supply.

Note

When you connect a microphone to the AUDIO IN connector for channel 1 and 2, set the appropriate LINE/MIC/+48V ON switch to +48V ON or MIC.

5-5-3 Attaching a UHF Portable Tuner (for a UHF Wireless Microphone System)

To use a Sony UHF wireless microphone system, fit the WRR-810A/860A UHF Portable Tuner. For each of these UHF portable tuners, use the following attachment procedure. (The WRR-860A is taken as an example below.)

Refer to the UHF portable tuner manual for more information.

Using a BP-L60A Battery Pack

- 1** (1) Attach the tuner fitting (not supplied) to the back of the camcorder.
- ① Pass a screwdriver through the holes and tighten the screws.
 - ② Loosen the adjustment screws.
 - ③ Adjust the metal fitting position for a BP-L60A Battery Pack to be attached, and tighten the adjustment screws to fix its position.
 - ④ Attach the BETACAM holder kit supplied with the tuner.
- (2) Attach the battery pack.

For more information about attaching the BP-L60A Battery Pack, see Section 5-1-1 “Using a BP-L60A Battery Pack” (page 5-1).

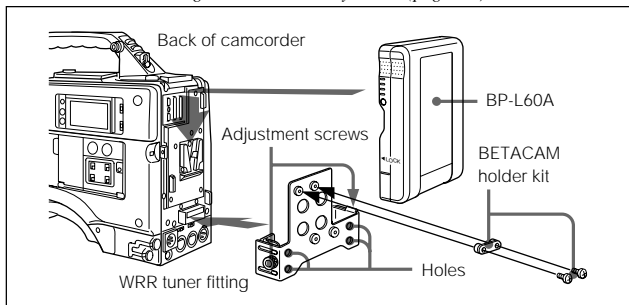

2 Mount the tuner on the WRR tuner fitting.

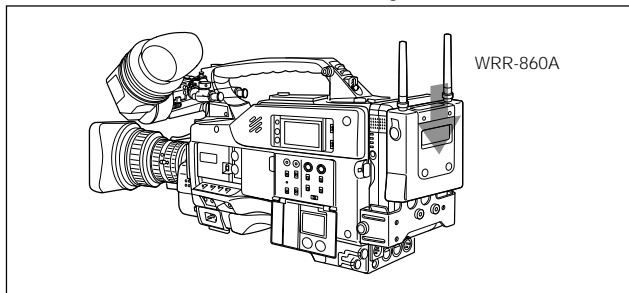

3 Connect the tuner power cord to the DC OUT connector of the camcorder, and the audio output cable to the AUDIO IN connector for channel 1 or channel 2.

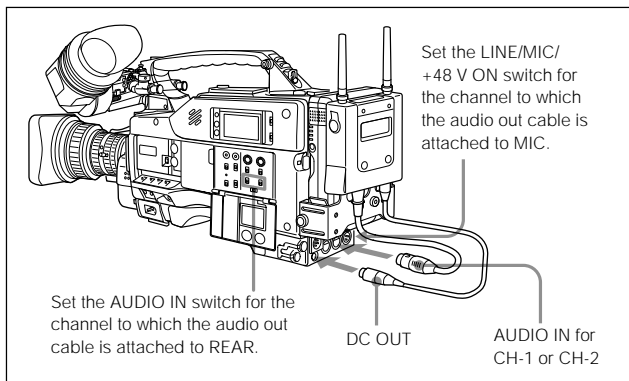

5-5-4 Connecting Line Input Audio Equipment

Connect the audio output connector of the audio equipment that supplies the line input signal to the AUDIO IN CH-1 or CH-2 connector.

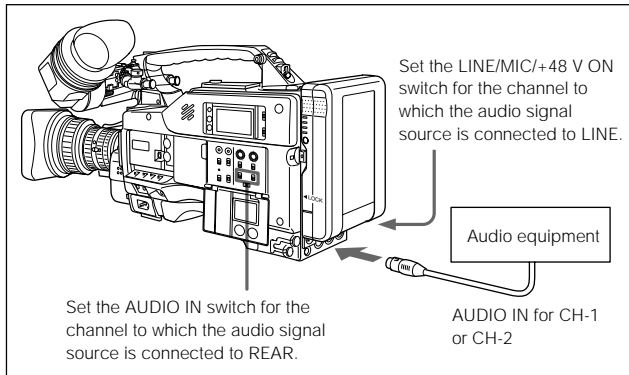

Line input connection

5-6 Tripod Mounting

You can easily mount and dismount the camcorder on a tripod by using the supplied tripod adaptor.

1 Attach the tripod adaptor to the tripod.

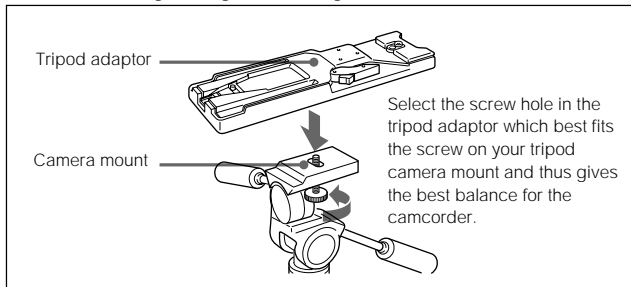

2 Mount the camcorder on the tripod adaptor.

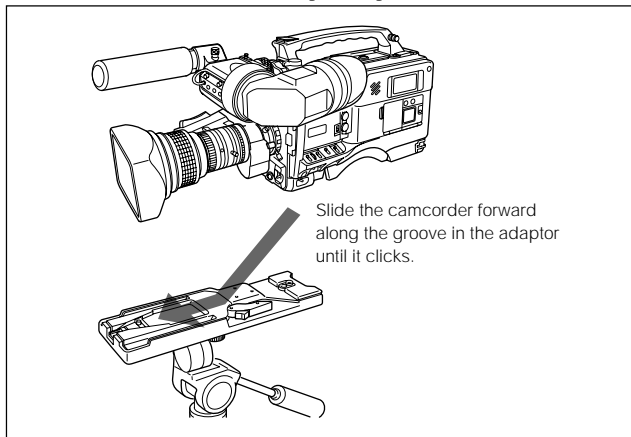

Removing the camcorder from the tripod adaptor

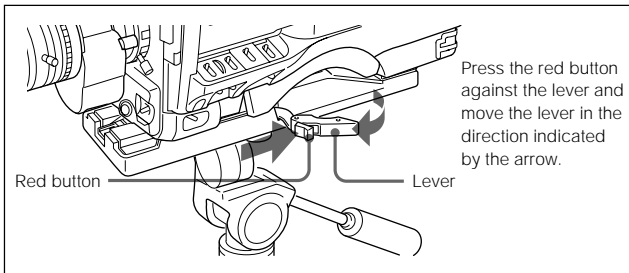

Removing the camcorder from the tripod adaptor

Note

The tripod adaptor pin may remain in the engaged position even after the camcorder is removed. If this happens, press the red button against the lever a second time and move the lever as shown below until the pin returns to the stowed position. If the pin remains in the engaged position, you will not be able to mount the camcorder on the tripod adaptor.

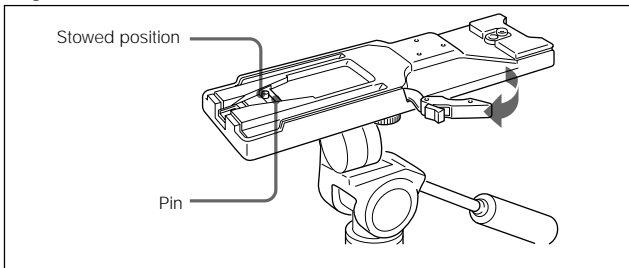

If the pin remains in the engaged position

5-7 Attaching the Shoulder Strap

Attach the supplied shoulder strap as shown below.

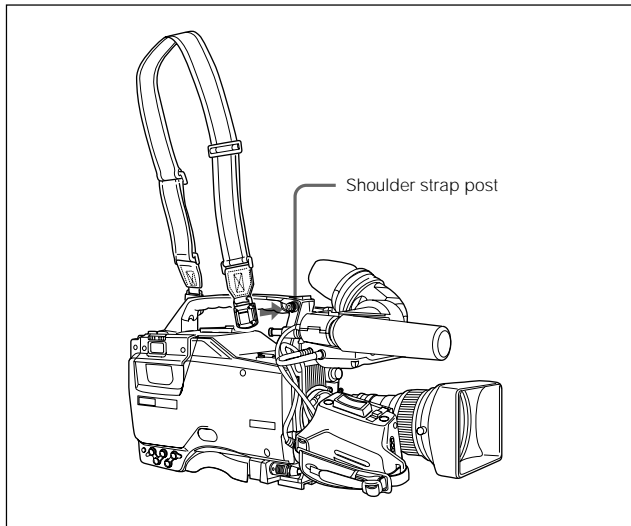

Attaching the shoulder strap

Attaching

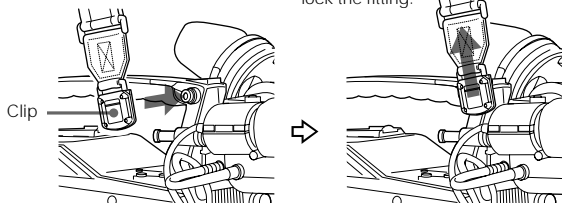

Attaching the shoulder strap

Removing

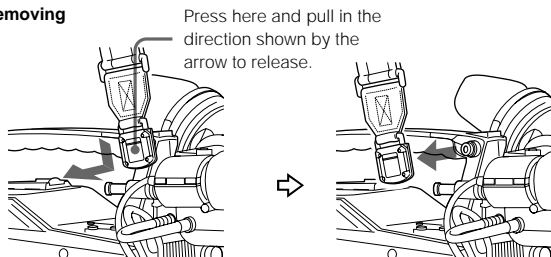

Removing the shoulder strap

5-8 Adjusting the Shoulder Pad Position

You can shift the shoulder pad from its center position (factory setting) backward or forward by up to 10 mm (3/8 inch). This adjustment helps you get the best balance for shooting with the camcorder on your shoulder.

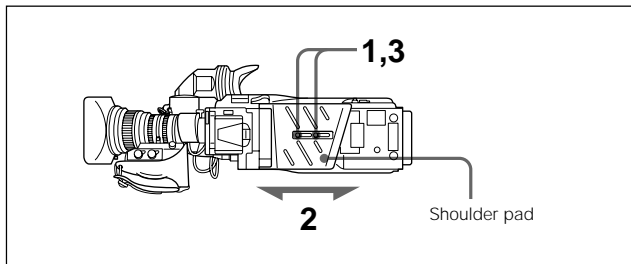

Adjusting the shoulder pad position

- 1** Loosen the two screws.
- 2** Slide the shoulder pad backward or forward until it is in the most convenient position.
- 3** Tighten the screws.

5-9 Putting On the Rain Cover

Attach the rain cover as illustrated below. You can insert and remove cassette tapes, operate various switches and controls, and mount the camcorder on the tripod adaptor with the rain cover attached.

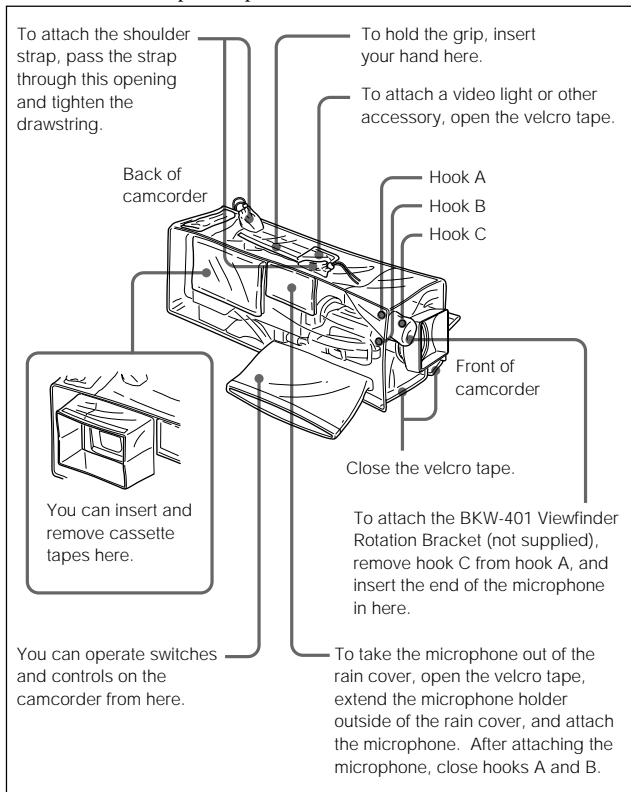

You can operate switches and knobs on the camcorder from here.

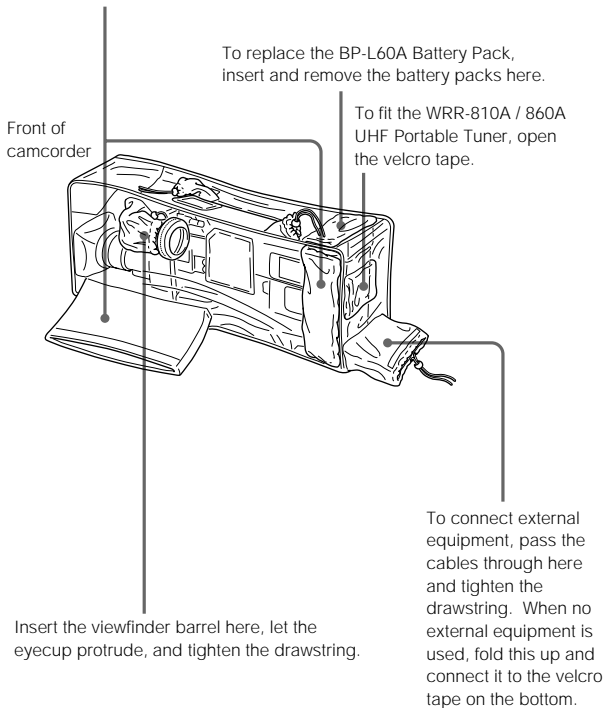

(Continued)

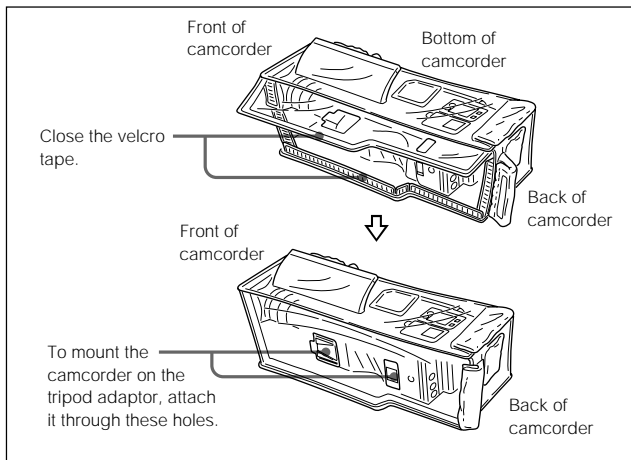

5-10 Connecting the Remote Control Unit

Connecting the RCP-700 Series Remote Control Unit (not supplied) enables remote control of the principal camera functions.

Turning the POWER switch of the camcorder to ON when the remote control unit is connected to the REMOTE connector (8-pin) automatically puts the camcorder into remote control mode. If you disconnect the remote control unit, remote control mode is canceled.

Notes

- Always turn the POWER switch to OFF before connecting or disconnecting the remote control cable.
- When you turn off the camcorder power, the settings and adjustments made with the switches and controls of the remote control unit are canceled. The settings and adjustments made with the setup menu are saved, but some of them are not written in the setup card.

Connecting the RM-B150 Remote Control Unit (not supplied)

Use the black cable supplied with the RM-B150 to connect the monitor output connector (Y signal) on the camcorder to the monitor input connector on the RM-B150. To output the character information that is displayed in the viewfinder screen as well, push the VF DISP switch on the camcorder to MENU while holding the MENU switch on the RM-B150 in the CANCEL position.

Connecting the MSU-700A/750 Master Setup Unit (not supplied)

Connecting the MSU-700A/750 Master Setup Unit enables various camera settings and adjustments to be made.

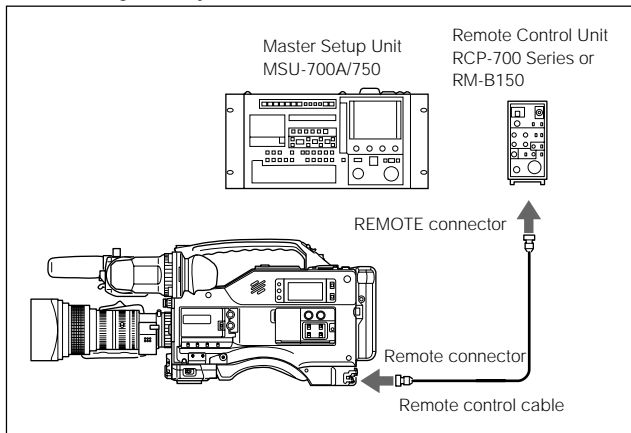

Connecting the remote control unit

Extension cable lengths

An extension cable is supplied with the RCP-700 series or RM-B150 Remote Control Unit and MSU-700 Master Setup Unit. The length of each cable is as follows:

RCP-700 series: 10 meters

RM-B150: 100 meters

MSU-700A/750: 200 meters

6-1 Testing the Camcorder Before Shooting

Check the functions of the camcorder before setting out for a shooting session, preferably by operating the camcorder together with a color video monitor.

6-1-1 Preparations for Testing

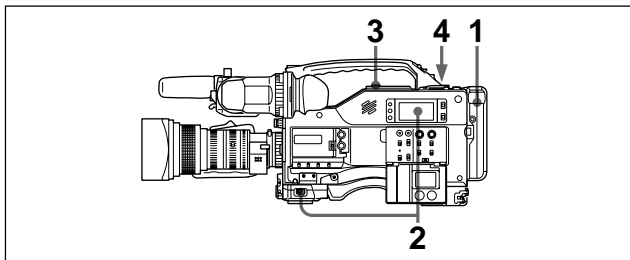

- 1** Attach a fully charged battery pack.
- 2** Set the POWER switch to ON and check that the HUMID indicator does not appear and that the BATT indicators shows at least five segments.
 - If the HUMID indicator appears, wait until it disappears.
 - If the BATT indicator does not show at least five segments, replace the battery pack with a fully charged one.
- 3** Check that there are no obstructions near the cassette lid, and then press the EJECT button to open the cassette lid.
- 4** After checking the points below, load the cassette and close the cassette lid.
 - The cassette is not write-protected.
 - There is no slack in the tape.
 - Condensation does not form in the tape.

Condensation

If you move the camcorder from a very cold place to a warm place, or use it in a damp location, condensation may form on the head drum. Then, if the camcorder is operated in this state, the tape may adhere to the drum and cause a failure or even permanent damage. Do the following to prevent this from happening.

- When moving the camcorder from a cold place to a warm place, be sure no cassette is loaded in the camcorder.
- Whenever you turn on the power, check that the HUMID indicator does not appear. If it appears, wait until it disappears before loading a cassette.

For more information, see Section 3-1-1 “Loading and Unloading a Cassette” (page 3-1) and Section 6-3 “Operation Warnings” (page 6-14).

6 6-1-2 Testing the Camera

Set the switches and selectors as follows.

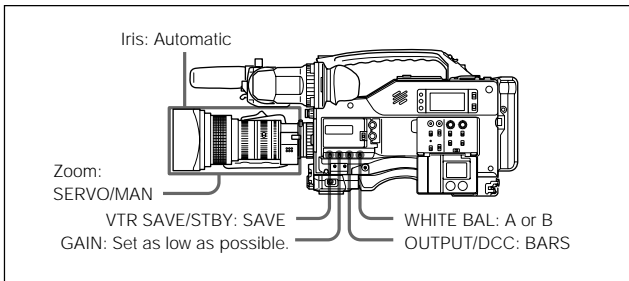

Testing the viewfinder

- 1** Adjust the position of the viewfinder.
- 2** Check that the color bars are displayed in the viewfinder, and adjust the BRIGHT, CONTRAST, and PEAKING controls to give the best color bar display.
- 3** Check each of the following operations.
 - (1) Set the DISPLAY switch to MENU and check that the setup menu is displayed on the viewfinder screen.
 - (2) Turn the MIC/MENU knob and check that the setup menu page changes to the next page.
 - (3) Push the MIC/MENU knob and check that settings of each item of the selected page are displayed.
 - (4) Turn the MIC/MENU knob and check that the arrow (→) moves within the page.
 - (5) Push the MIC/MENU knob and check that the arrow (→) changes to a question mark (?).
 - (6) Turn the MIC/MENU knob and check that the setting of the selected item or the ON/OFF indicator changes.
- 4** Set the OUTPUT/DCC switch to CAM, and change the FILTER selector position in the sequence of 1, 2, 3, 4. Check that the FILTER indicator on the viewfinder screen displays the correct numbers.

(Continued)

-
- 5** Check each of the following operations and make sure that the **!** indicator lights if the corresponding item has been turned on in the **!** IND page.
- (1) Set the gain to anything but 0 dB by using the GAIN selector and the GAIN SW page of the OPERATION menu.
 - (2) Set the SHUTTER selector to ON.
 - (3) Set the WHITE BAL switch to PRST.
 - (4) Use the lens extender.
 - (5) Set the FILTER selector to anything but “1B”.
- 6** Push the SHUTTER selector from ON to SEL repeatedly, and check that the shutter setting changes on the viewfinder screen.
- 7** Pointing the camera at a suitable subject, focus the camera and check the picture on the viewfinder screen.
- 6** **8** Set both of the AUDIO IN switches to FRONT, and check that when sound is input to a microphone connected to the MIC IN connector on the front of the camcorder, the audio level indication appears on the viewfinder screen.
- 9** Check that setting the ZEBRA switch to ON and OFF makes the zebra pattern appear and disappear on the viewfinder screen.

Note

The current display status may inhibit one or more of the displays or operations mentioned in steps **3** to **9**. If this happens, set the desired items in the VF DISPLAY page of the OPERATION menu.

Testing the iris and zoom functions

- 1** Set the zoom to automatic zoom mode and check that the power zoom operates correctly.
- 2** Set the zoom to manual zoom mode and check the zoom functions manually.
- 3** Set the iris switch on the lens to **AUTO** and point the camera at objects of different brightness. Check that the automatic iris adjustment operates correctly.
- 4** Set the iris switch on the lens to **MANUAL** and check that turning the iris ring manually adjusts the iris correctly.
- 5** Hold down the instant automatic iris button on the lens and point the camera at objects of different brightness. Check that the iris ring turns as the instant automatic adjustment is made.
- 6** Set the iris switch on the lens back to **AUTO** and check the following points when the **GAIN** selector is moved from **L** to **M** to **H**.
 - For objects of the same brightness, the iris is adjusted to correspond to the change in setting.
 - The gain indicator on the viewfinder screen changes to correspond to the change in setting.
- 7** If an extender mechanism is incorporated in your lens, put it into the operative position and check the effect.

6-1-3 Testing the VTR

Perform tests (1) to (6) consecutively.

(1) Testing the tape transport functions

- 1** Set the VTR SAVE/STBY switch to SAVE and check that the VTR SAVE indicator in the viewfinder goes on.
- 2** Set the VTR SAVE/STBY switch to STBY and check that the VTR SAVE indicator in the viewfinder goes off.
- 3** Set the F-RUN/SET/R-RUN switch to R-RUN.
- 4** Set the DISPLAY (LCD) switch to CTL.
- 5** Press the VTR START button and check the following points.
 - The tape reels are turning.
 - The counter indication is changing.
 - The REC indicator in the viewfinder is on.
 - The RF and SERVO indicators on the display panel are off.
- 6** Press the VTR START button again and check that the tape stops and that the REC indicator in the viewfinder goes off.
- 7** Repeat the checks of steps **5** and **6**, this time using the VTR button on the lens.
- 8** Press the RESET button and check that the counter display goes to "00:00:00:00".
- 9** Turn on the LIGHT switch and check that the display panel is illuminated.

-
- 10** Hold down the REW button to rewind the tape for a while, then press the PLAY button. Check that the rewind and playback functions operate normally.
 - 11** Press the STOP button and press the F FWD button. Check that the fast forward function operates normally.

(2) Testing the automatic audio level adjusting functions

- 1** Set the AUDIO IN switches to FRONT.
- 2** Set the AUDIO SELECT switches to AUTO.
- 3** Aim the microphone connected to the MIC IN connector at a suitable sound source. Check that the level indications for both channels correspond to the sound level.

(3) Testing the manual audio level adjusting functions

- 1** Set the AUDIO IN switches to FRONT.
- 2** Set the AUDIO SELECT switches to MANUAL.
- 3** Set the DISPLAY switch to ON.
- 4** Push the MENU switch to CANCEL, then turn the MIC/MENU knob. Check that the level indications in the viewfinder go up and down.

(Continued)

(4) Testing the earphone and speaker

- 1** Set the VTR SAVE/STBY switch to STBY.
- 2** Turn the MONITOR control and check that the speaker volume changes accordingly.
- 3** Connect an earphone to the EARPHONE jack. Check that the speaker sound is cut off and that you can hear the sound from the microphone in the earphone.
- 4** Turn the MONITOR control and check that the earphone volume changes accordingly.

6 (5) Testing external microphones

- 1** Connect external microphones to the AUDIO IN CH-1/CH-2 connectors.
- 2** Set the LINE/MIC/+48V ON switches to MIC.
- 3** Set the AUDIO IN switches to REAR.
- 4** Aim the microphones at a sound source.
- 5** Check that the audio level meter in the display panel and the audio indication in the viewfinder reflect the changing sound level.

(6) Checking the functions of the user bits and time code

- 1** Set the user bits as required.
For more information see Section 4-4-1 “Setting the User Bits” (page 4-17).
- 2** Set the time code.
For more information, see Section 4-4-2 “Setting the Time Code” (page 4-19).
- 3** Set the F-RUN/SET/R-RUN switch to R-RUN.
- 4** Press the VTR START button, and check that the tape starts and that the counter indication changes.
- 5** Press the VTR START button again, and check that the tape stops and that the counter indication also stops changing.
- 6** Set the F-RUN/SET/R-RUN switch to F-RUN, and check that the counter indication changes regardless of whether the tape is running.
- 7** Set the DISPLAY (LCD) switch to U-BIT, and check that the user bit value that was set is displayed.

6-2 Maintenance

6-2-1 Cleaning the Video Heads

To clean the video heads, use a Sony BCT-HD12CL Cleaning Cassette. Follow the instructions given with the cleaning cassette, as incorrect or excessive use could damage the video heads.

To clean the heads, follow the procedure below.

- 1** Load the cleaning cassette according to the procedure described in “Loading a cassette” (page 3-1).
- 2** After the cleaning cassette is inserted, the tape runs automatically in PLAY mode for about 3 seconds to clean the head.
- 3** After the tape runs, the cleaning cassette is automatically evacuated.

Note

Do not run the cleaning cassette 5 or more times consecutively.

6-2-2 Cleaning the Viewfinder

Use a dust blower to clean the CRT screen and mirror inside the barrel. Clean the lens and protecting filter with a commercially available lens cleaner.

Caution

Never use organic solvents such as thinners.

Disassembling the eyepiece for cleaning

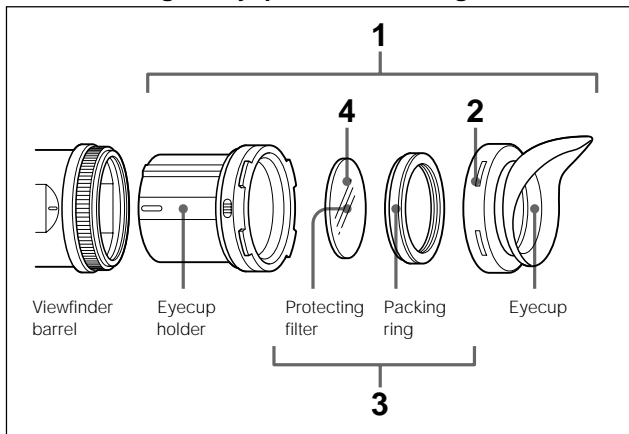

- 1** Detach the eyepiece from the viewfinder barrel.

For the detaching procedure, see the following “Detaching the eyepiece” on the next page.

- 2** Remove the eyecup from the eyecup holder.
- 3** Remove the protecting filter, together with the packing ring, from inside the eyecup folder.
- 4** Detach the protecting filter from the packing ring.

Detaching the eyepiece

- 1 Turn the eyepiece locking ring fully counterclockwise to line up the red match mark on the locking ring with the red match mark on the viewfinder barrel.

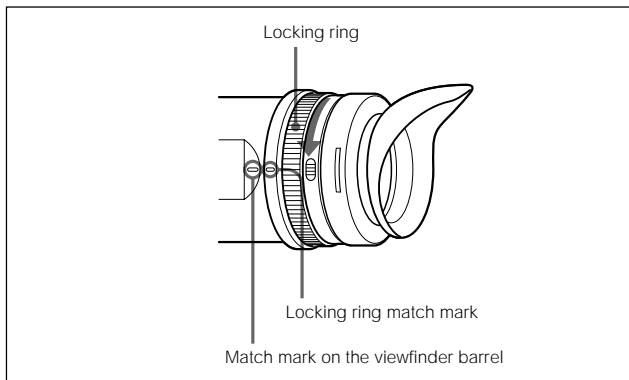

- 2 Detach the eyepiece.

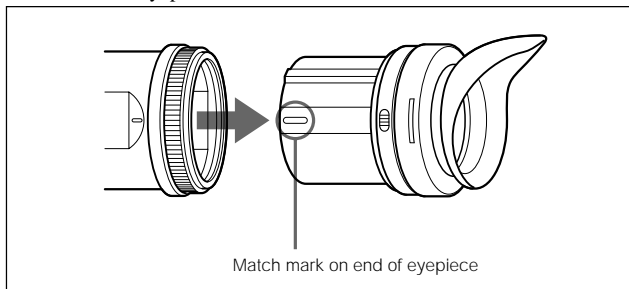

Refitting the eyepiece

- 1 Align the match mark on the eyepiece locking ring with that on the viewfinder barrel.
- 2 Align the match mark on the end of the eyepiece (see step 2 in “Detaching the eyepiece” on the previous page) with that of the eyepiece locking ring, then insert the eyepiece into the viewfinder barrel.
- 3 Turn the eyepiece locking ring clockwise until its “LOCK” indication arrow points to the match mark on the viewfinder barrel.

Fog-proof filter

Depending on the temperature and humidity, the protecting filter may mist because of vapor or your breath. To ensure that the viewfinder is always clear, replace the protecting filter with a fog-proof filter (Part No. 1-547-341-11, not supplied).

Fitting the fog-proof filter

Replace the protecting filter on the packing ring with the fog-proof filter. Be sure to correctly assemble the fog-proof filter, the packing ring, and the eyecup so that the reassembled eyepiece is waterproof.

Note

When cleaning the fog-proof filter, wipe it very gently with a soft cloth to avoid impairing the anti-fogging coating.

6-3 Operation Warnings

When a problem occurs either at power on or during operation, warnings are given by the WARNING indicator and TALLY indicator, in the

Operation warnings

Display panel	Indicators in the viewfinder			Warning sounds	
Warning/ Battery status indication	Flashing/ continuous	:Continuous	:2 flashes/s	●))) ●)) ●)) ●))) : 4 beeps/s ●))))))))))):1 beep/s ●))))))))))): Continuous beep	
		:1 flash/s	:4 flashes/s		
		WARNING	REC/tally	BATT	
RF	Continuous ^{a)}			●))) ●)) ●)) ●))) ^{a)}	
SERVO	Continuous			●))) ●)) ●)) ●)))	
	Continuous			●))))))))))))))))))))))))))	
HUMID	Continuous			●))) ●)) ●)) ●))) ^{a)}	
				●)))))))))))))))))))))))))) ^{b)}	
SLACK	Continuous			●))))))))))))))))))))))))))	
TAPE ^{c)}	Flashing ^{a)}	^{a)}		●))))))))))))))))))	
TAPE and E	Flashing			●))))))))))))))))))))))))))	
BATT	Flashing				●)))))))))))))) ^{d)}
BATT and E	Flashing				●))))))))))))))))))))))))))
(No indication on the display panel)					

a) During recording

b) During playback, fast forward, or rewind

display panel, and in the viewfinder. The speaker and earphone also give audible warnings.

Problem	VTR action	Corrective action
Video head gap clogged or problem in recording circuit	After clogged head is detected, recording continues but is substandard.	Clean the heads. If recording is still substandard, turn off the power and consult your Sony representative.
Servo lock lost	Recording continues but is substandard.	Turn off the power and consult your Sony representative. Note that this indication may be given momentarily when the tape starts moving, but this does not indicate a problem.
CPU Interface error	VTR stops.	Turn off the power and consult your Sony representative.
Condensation on the head drum	Recording continues but stops if the tape sticks to the head drum. Playback, fast forward, and rewind do not operate.	Stop the tape and wait until the HUMID indicator disappears.
The tape cannot be wound properly.	An error code appears in the time code display section of the display panel. Look up the error code in the Maintenance Manual.	Remove the cassette by the method described in the Maintenance Manual. Close the cassette lid without loading a cassette, turn off the power, and consult your Sony representative.
Near the end of tape	Operation continues.	Be prepared to change the cassette.
End of tape	Record, playback, and fast forward do not operate.	Change the cassette or rewind the tape.
Low battery	Operation continues.	Change the battery.
Dead battery	Operation stops.	Change the battery.
CPU Interface error	Recording continues, but some operations such as recording review and cueing do not operate. If another problem also occurs, its indication is given priority.	Turn off the power and consult your Sony representative.

c) Also, "5-0" appears for the tape remaining indication.

d) During recoding or stop mode

Notes on CCD image sensors

Vertical smear

Smear tends to be produced when an extremely bright object is being shot; it is more likely to occur with a faster electronic shutter speed.

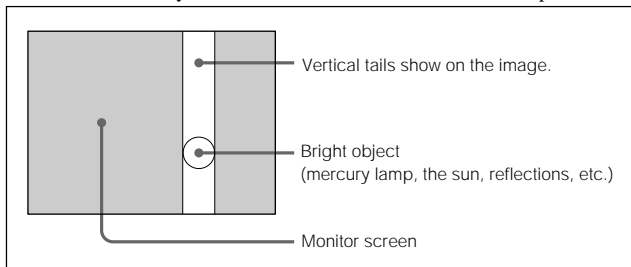

Vertical smear

Aliasing

When patterns of stripes or lines are shot, they may appear jagged.

Specifications

Power voltage

12 $^{+5.0}_{-1.0}$ V DC

Power consumption

40 W (with 12 V DC supply, when recording)

Operating temperature

0°C to +40°C (32°F to 104°F)

Operating humidity

25% to 85% (relative humidity)

Storage temperature

-20°C to +60°C (-4°F to +140°F)

Mass

Approx. 8 kg (17 lb 10 oz) (with lens, cassette, and BP-L60A Battery Pack)

Dimensions

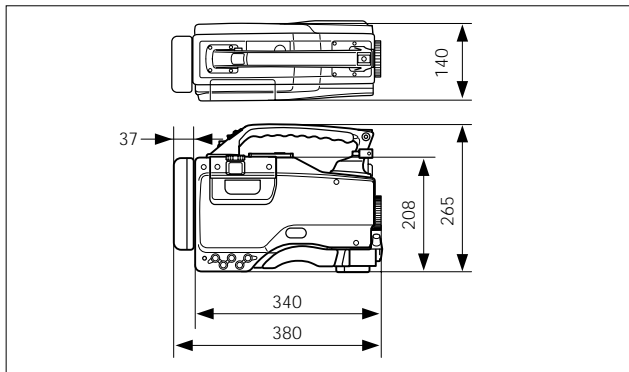

Dimensions in mm

Video Camera Section

General

Imager

$\frac{2}{3}$ -inch frame-interline-transfer type CCD with 2,200,000 pixels

Effective picture elements

1920(H) x 1080(V)

Imager Configuration

RGB 3 CCDs

Spectral system

F1.4 prism system (with quartz filter)

Built-in filters

CC filter

A: 5600K

B: 3200K

C: 4300K

D: 6300K

ND filter

1: Clear

2: $\frac{1}{4}$ ND

3: $\frac{1}{16}$ ND

4: $\frac{1}{64}$ ND

Lens mount

Special bayonet type

Sensitivity (60 I/59.94 I)

89.9% reflection chart, 2000 lx (F10 standard)

VTR Section

General

Usable cassette tapes

BCT-22HD/40HD 1/2-inch HDCAM cassette tapes

Tape speed

approx. 96.7 mm/s (at 30 frames)

Record/playback time

40 minutes (at 30 frames) (using BCT-40HD video cassette)

48 minutes (at 25 frames) (using BCT-40HD video cassette)

50 minutes (at 24 frames) (using BCT-40HD video cassette)

Fast forward time

Approx. 6 minutes (using BCT-40HD video cassette)

Rewind time

Approx. 6 minutes (using BCT-40HD video cassette)

Continuous recording time

Approx. 80 minutes (using BP-L60A Battery Pack)

A

Digital video

Digital video signal

Sampling frequency	Y	74.25 MHz
	P _B /P _R	37.125 MHz
Quantization	10 bits/sample (8 bits/sample for compression processing)	
Compression	Coefficient recording system	
Channel coding	S-NRZI PR-IV	
Error correction	Reed-Solomon code	
Error concealment	Adaptive three dimensional	

Audio (with standard playback machine)

Frequency response	20 Hz to 20 kHz ^{+0.5} _{-1.0} dB
Dynamic range	85 dB min. (emphasis ON)
Distortion	0.08% max.
Cross talk	-70 dB max.
Wow and flutter	Below measurable limit

Input/output connectors

Signal inputs

AUDIO IN CH-1/CH-2 (XLR, 3-pin, female)

-60 dBu/+4 dBu

(0 dBu = 0.775 V_{rms}.)

MIC IN (XLR, 3-pin, female)

-60 dBu

GENLOCK IN (BNC type)

1.0 V_{p-p}, 75 W

TC IN (BNC type)

0.5 V to 18 V_{p-p}, 10 k W

Signal outputs**MONITOR OUT (BNC type) (Y, P_B, P_R)**

1.0 V_{p-p}, 75 W, unbalanced

AUDIO OUT (XLR, 5-pin, male)

0 dBm

TC OUT (BNC type)

1.0 V_{p-p}, 75 W

EARPHONE (minijack)

8 Ω, -∞ to -18 dBs variable

Others**DC IN (XLR, 4-pin, male)**

11 to 17 V DC

DC OUT (4-pin)

11 to 17 V DC, maximum current 0.1 A

LENS (12-pin)**REMOTE (8-pin)**

Supplied Accessories

- Microphone (super cardioid directional, external power supply type) (1)
- Tripod Adaptor (VCT-14) (1)
- Shoulder Strap (1)
- Rain Cover (1)
- Operation Manual (1)
- Maintenance Manual (1)

Recommended Additional Equipment

Viewfinder

- HDVF-20A HD Electronic Viewfinder
- HDVF-C30W HD Electronic Viewfinder

Power supply and related equipment

- BP-L60A Battery Pack
- BC-L100 Battery Charger (for BP-L60A Battery Pack)
- AC-550 AC Adaptor

HDCAM cassette tapes

- BCT-22HD/40HD

Memory label

- MLB-1M-100

Camera adaptor

- HDCA-901

Viewfinder and related equipment

BKW-401 Viewfinder Rotation Bracket

Fog-proof filter (Part No. 1-547-341-11)

Lens assembly (farsighted) (Part No. A-8262-537-A)

Lens assembly (low magnification) (Part No. A-8262-538-A)

Lens assembly (standard magnification with special compensation for aberrations) Part No. A-8267-737-A)

Optical attachments

ND filter ($1/8$ ND) (Part No. 3-174-685-01)

ND filter ($1/32$ ND) (Part No. 3-174-683-01)

Cross filter (Part No. 3-174-682-01)

Mount ring (Part No. 3-186-442-01)

Consult your Sony representative for more information about these filters.

Equipment for remote control

RCP-700 Series Remote Control Unit

RM-B150 Remote Control Unit

MSU-700A/750 Master Setup Unit

Audio equipment

C-74 microphone

ECM-MS5 stereo microphone

CAC-12 Microphone Holder

CRS-3P Cradle Suspension

WRR-810A/860A UHF Portable Tuner

WRT-27 UHF Transmitter

BTA-27 UHF Portable Tuner Attachment Kit

For Audio equipment described above, confirm whether the connector is male or female and the number of pins on the connector.

The audio input connectors of the camcorder are female and 3-pin and the audio output connectors are male and 5-pin. A converting adaptor may be required depending on the audio equipment to be connected to the camcorder.

Equipment for maintenance and easier handling

BCT-HD12CL Cleaning Cassette

LC-HD7 Carrying Case

LC-304SFT Soft Carrying Case

EX-410 Extension Circuit Board

Design and specifications are subject to change without notice.

A

Glossary

Aliasing

Distortion that occurs when an analog signal is sampled to create a digital signal.

Bayonet mount

A type of lens mount. The lens can be inserted into the lens mount and quickly locked in place by simply rotating a lens locking ring.

Black balance adjustment

To balance the black levels of the R, G, and B channels of a video camera so that black has no color.

Black set

A reference level for black balance adjustment.

CC filter

Color Conversion filter. An optical filter for adjusting the white balance by optically correcting the color temperature of the subject.

CCD

Charge-Coupled Device. A solid state imager used in most video cameras in place of a pickup tube. The device converts light levels into electrical charges that are first stored and then output in the form of voltage variations.

Center marker

A cross that indicates the center of the image on the viewfinder screen.

CTL

Control signal in the form of regular pulses recorded along a longitudinal track on the video tape. By counting these pulses, it is possible to determine the number of frames, and hence the tape running time. Used mainly to adjust the tracking position of video heads, and to achieve time code continuity in continuous recording.

Color bar signal

A test signal that can be displayed as vertical bars of different colors on a color video monitor. This signal is used to check chrominance functions of color television and video systems such as cameras and monitors.

Color temperature

The temperature in Kelvins (K) to represent the color of a light source, determined by heating a perfectly black body until its color matches that of the light source. Color temperature is higher when the color is bluish and lower when reddish.

Condensation

Moisture condensation on the VTR tape transport mechanism. Condensation on the head drum causes the tape to stick to the drum, resulting in damage to the tape and a malfunction of the VTR.

CRT

Cathode-Ray Tube. Video camera viewfinders are equipped with a CRT image display so you can monitor what you are shooting.

DCC

Dynamic Contrast Control. Also called automatic knee. A video camera containing a DCC circuit can handle a wide dynamic range of luminance by automatically varying the knee point and knee slope.

Drop frame mode

To eliminate the discrepancy between the actual time and the time code value generated by the time code generator when the format of the camcorder is set to either 29.97 Psf or 59.94 I, drop frame mode drops two frames (frames 00 and 01) from the time code value at the beginning of each minute except every tenth minute.

E-E mode

Electric-to-Electric mode. When you operate a VTR in E-E mode, input video and/or audio signals pass through electric circuits only and then come out from the output connectors, without passing through electromagnetic conversion circuits such as recording heads. You can use E-E mode to directly check and monitor the input signals without recording them on tape.

EFP

Electronic Field Production. The use of electronic equipment such as portable video cameras, VTRs, and sound equipment for television production outside studios.

ENG

Electronic News Gathering. The use of electronic equipment such as portable video cameras, VTRs, and sound equipment for the production of daily news stories and short documentaries.

Ff

See also Flange focal length.

FIT

Frame Interline Transfer. A type of CCD imager featuring substantially reduced vertical smear.

Flange focal length

The distance from the plane of the lens mounting flange to the image focal plane. Abbreviated to Ff.

Flare

Dark or colored flashes caused by signal overload through extreme light reflections of polished objects or very bright lights. As a result, the dark part of the image becomes bleached-looking.

Flicker

Repeated change of brightness on the screen.

Genlock

Generator lock. To synchronize the pulse generator built into video equipment to an external reference (master) synch signal.

HAD

Hole-Accumulated Diode. A CCD sensor structure designed to suppress certain types of noise inherent to CCDs.

Horizontal resolution

The capability of a video camera or a display unit to preserve detail in the horizontal direction. Usually expressed as the number of vertical lines that can be distinguished in the reproduced image of a test chart.

Hunting

Repeated brightening and darkening of an image resulting from repeated response to automatic iris control.

LTC

Longitudinal Time Code. A time code recorded along the tape in the forward direction of a tape run. A VTR cannot reproduce LTC when tape run stops to output a still picture. The output level is very low when tape runs slowly, so an LTC read error is likely to occur while the VTR is playing back in slow motion. See also Time code and VITC.

Memory Stick

Memory Stick is the removable storage media used with the camcorder. You can easily save and delete the data.

ND filter

Neutral Density filter. ND filters reduce the amount of incident light equally across the entire visible wavelength range without affecting color.

Non-drop frame mode

Non-drop frame mode does not perform the processing of drop frame mode. As a result, when the format of the camcorder is set to either 29.97 Psf or 59.94 I, there will be a discrepancy between the actual time and the time code value of about 86 seconds in one day.

Override

Temporarily allows the iris to be manually adjusted while in automatic iris adjustment mode.

Shutter speed

The length of time for which the shutter stays open. The higher the shutter speed, the more clearly a moving object can be shot.

S/N

Signal-to-Noise ratio. The ratio of the strength of the desired signal to the accompanying electronic interference, the noise. If S/N is high, sounds are reproduced with less noise and pictures are reproduced clearly without snow.

Time code

A digitally encoded signal that is recorded on video tape to identify each frame of video by hour, minute, second, and frame number. There are two kinds of recorded signals: longitudinal time code (LTC) and vertical interval time code (VITC).

Time code synchronization

To synchronize the built-in time code generator of video equipment such as a VTR to an external time code.

User bits

Bits provided in the time code that the user can use to record such information such as date, scene number, or reel number on video tape.

Vertical smear

A bright vertical line that appears on the screen when shooting a very bright object with a CCD camera. Also called smear.

Video gain

Amount of amplification for video signals, expressed in decibels (dB).

VITC

Vertical Interval Time Code. Unlike LTC, VITC is recorded in the same tracks as the video information, so they can be read with editing recorder. See also Time code and LTC.

White balance adjustment

In the light of a particular color temperature, to adjust the white levels of the R, G, and B channels of a color video camera so that any white object shot in that light is reproduced as a truly white image.

White shading

When shooting a white object, the upper and lower portions of the screen may appear magenta or green while the central portion appears white. This is called white shading.

Zebra pattern

In a video camera, striped patterns that appear in the viewfinder screen to indicate areas of the image where the video level is approximately 70% and 100%. Used to confirm the video level of the subject. If a zebra pattern appears on the skin when the subject is a human being, that is a correct exposure.

Zoom

To gradually change the field of view of a camera lens from wide to narrow angle (zoom in) or narrow to wide angle (zoom out).

Index

A

- AC-550 AC Adaptor 1-7, 2-1, 5-1, 5-5
- Accessory attachments 2-3
- AC power supply 1-7, 5-5
- Adjusting the flange focal length 5-12
- Adjustments and settings for recording
 - audio level 4-13
 - black balance and white balance 4-1
 - electronic shutter 4-9
 - memory stick operations 4-91
 - PAINT menu 4-72
 - setup menu display on the viewfinder screen 4-28
 - setup using the OPERATION menu 4-47
 - status display on the viewfinder screen 4-34
 - time data 4-17
- ADVANCE button 2-32
- ALARM volume control 2-9
- Aliasing 6-16
- Anton Bauer Ultralight System 5-6
- Assignable switches 2-28, 4-66
- Attaching a UHF portable tuner 5-22

Audio

- audio functions 2-5
- audio level adjustment 4-13
- audio level indicator 4-37, 4-49
- level meter 2-38, 4-14
- line input 5-24
- testing the audio functions 6-7
- AUDIO IN switches 2-7
- AUDIO IN CH-1/CH-2 connectors and LINE/MIC/+48 V ON switches 2-8
- AUDIO OUT connector 2-8
- AUDIO SELECT switches 2-7
- AUTO W/B BAL switch 2-19

B

- BACK TALLY switch 2-36
- BACK TALLY indicator 2-36
- Battery (See also Power supply.)
 - Anton Bauer Ultralight System 5-6
 - Avoiding breaks in operation due to dead batteries 5-4
 - BATT indicator 2-38, 3-5, 6-1, 6-14
 - Battery attachment 2-1
 - Battery status indicator 2-38, 6-14
 - BC-L100 Battery Charger 1-7, 5-1, A-6
 - Hunting 4-8

Using the BP-L60A Battery
Pack 1-7, 2-1, 5-1, 5-22
BC-L100 1-7, 5-1, A-6
BCT-HD12CL 6-10, A-8
BETACAM holder kit 5-22
BKW-401 1-6, 5-10, A-7
Black balance
 adjusting 4-2
 error message 4-4
 memory 4-4
BP-L60A 1-7, 2-1, 5-1, 5-22, A-6
BREAKER button 2-2
BRIGHT control 2-14

C

C-74 1-7, 5-17, A-7
CAC-12 Microphone Holder 1-7,
5-18
CAC-12 1-7, 5-18, A-7
Camera section
 features 1-1
 specifications A-2
 testing 6-2
Camera synchronization
 camera synchronization 4-27
 changing to an external power
 supply 4-27
 connection example 4-23
 procedure 4-25
 releasing time code
 synchronization 4-27
 setting the user bits 4-26
Cameraman tally indicator 2-16

Cassette tape
 loading 3-1
 preventing accidental
 erasure 3-4
 slack checking 3-3
 unloading 3-3
 usable cassettes A-6
CC filter 2-18, 4-6
Center marker 2-13
Cleaning
 BCT-HD12CL cleaning
 cassette 6-10, A-8
 video heads 6-10
 viewfinder 6-10
Color playback 3-14
Condensation 6-2
Continuous recording 3-9
CONTRAST control 2-14
Control signal display 2-32, 2-40
CRS-3P Cradle Suspension 5-18,
A-7
CTL 2-32, 2-40
CUE IN switch 2-8

D

D5600K mode indicator 4-35, 4-49
DCC function 2-20
DC IN connector 2-1
DC OUT connector 2-8
DF/NDF switch 2-34

DIAG button 2-36
Diopter adjustment ring 2-15
Display panel
 tape status, battery status, and
 level indicators 2-38
 status and warning
 indicators 2-39, 6-14
 time code displays 2-40
DISPLAY switch 2-28
DISPLAY (LCD) switch 2-32
DISPLAY/ASPECT switch 2-14,
4-56
Drop frame/non-drop frame mode
 DF/NDF switch 2-34
 switching the mode 4-20

E

Earphone checking 6-8
EARPHONE jack 2-12
ECS mode 4-9, 4-12
E-E sound 2-11
EJECT button 2-25
Electronic shutter
 See Shutter.
Equipment setup
 adjusting the flange focal
 length 5-12
 adjusting the shoulder pad
 position 5-29
 adjusting the viewfinder 5-7
 attaching the shoulder strap
5-27

audio input system 5-14
 connecting the remote control
 unit 5-33
 mounting the lens 5-11
 power supply 5-1
 putting on the rain cover 5-30
 storing the camcorder in the
 carrying case 5-7
 tripod mounting 5-25
Error messages
 adjusting the black balance
 4-4
 adjusting the white balance
 4-8
 memory stick operations
 4-98, 4-102
Extended Clear Scan mode
 See ECS mode.
Extender indicator 4-35, 4-49
External microphone
 testing 6-8
 use 5-18
External time code 4-23
Eyecup 2-13, 6-11

F

- F-stop indicator 4-36, 4-49
- F FWD button and indicator 2-26
- Filter
 - CC filter 2-18, 4-6
 - filter indicator 4-35, 4-49
 - fog-proof filter 6-13
 - ND filter 2-18, 4-6
 - protecting filter 6-11
 - selecting 2-18, 4-6
- FILTER selector 2-17
- Flicker 4-10
- F-RUN/SET/R-RUN switch 2-33
 - free run/recording run switch 2-33, 4-18, 4-20
- Fog-proof filter 1-6, 6-13, A-7

G

- Gain
 - gain indicator 4-35, 4-49
 - setting the GAIN selector values 4-58
- GAIN selector 2-20
- GENLOCK IN connector 2-22, 2-29

H

- HDCA-901 2-8, A-6
- HDVF-20A A-6
- Head cleaning 6-10
- HOLD button 2-32
- HUMID indicator 2-39, 3-5, 6-1, 6-14

I

- Iris setting indicator 4-36, 4-49

L

- Lens
 - locking lever 2-4
 - mounting 5-11
 - mount 2-3
 - mount cap 2-4
- LENS connector 2-4
- LEVEL controls 2-7
- Light shoe 2-3
- LIGHT switch 2-37
- Line input (audio) 5-24
- LTC 1-4, 4-18, 4-22

M

- Maintenance
 - video head cleaning 6-10
 - viewfinder cleaning 6-10
- MAINTENANCE menu 4-30, 4-85
- Memory Stick
 - compartment 2-27
 - handling 4-91
 - reading saved data from a Memory Stick 4-99
 - setting the file ID 4-103
 - writing data to a Memory Stick 4-94

Menu

- DIAGNOSIS menu 4-30
- MAINTENANCE menu 4-30, 4-85
- OPERATION menu 4-30, 4-47
- PAINT menu 4-30, 4-72
- TOP menu 4-28

Microphone

- supplied microphone 2-5
- using an external microphone 5-17
- using the supplied microphone 5-14

Microphone audio level adjustment 4-13

Microphone holder (A) 5-18

MENU switch 2-28

MIC IN connector 2-5

MIC/MENU knob 2-5, 2-19, 2-27

MLB-1M-100 3-16, A-6

MONITOR volume control 2-10

MONITOR switch 2-10

MONITOR OUT connector 2-23

MSU-700A/750 1-6, 5-34, A-7

N

ND filter 2-18, 4-6

Notes on CCD image sensors 6-16

O

OPERATION menu

- finding a page 4-47
- lighting the '!'
- INDicator 4-50
- operator file 4-69
- selecting the display items 4-48
- selecting the lens file 4-70
- setting the automatic iris 4-62
- setting the assignable switches 4-66
- setting the battery 4-64
- setting the D5600K mode 4-66
- setting the gain selector 4-58
- setting the marker display 4-55
- setting the viewfinder 4-60

OUTPUT/DCC selector 2-20

P

Page

- AUTO IRIS page 4-47, 4-62
- BATT ALARM 4-47, 4-64
- GAIN SW page 4-47, 4-58
- LENS FILE page 4-47, 4-70
- MARKER page 4-47, 4-55
- OPERATOR FILE page 4-47, 4-69
- OTHERS page 4-47, 4-66
- VF DISPLAY page 4-47, 4-48

ZEBRA/VF DTL 4-47, 4-60
'!' IND page 4-47, 4-50
PAINT menu 4-30, 4-72
PEAKING control 2-14
Playback
 checking the recording 3-13
 color playback 3-14
 parts and controls 2-13
 recording review 3-14
 using a color video monitor
 3-14
PLAY button and indicator 2-26
POWER switch 2-2
Power supply (See also Battery.)
 Anton Bauer Ultralight
 System 5-6
 dead battery 5-4
 power supply 2-1
 using AC power 1-7, 5-5
 using the BP-L60A Battery
 Pack 1-7, 5-1
Power voltage indicator 4-36
Precautions 1-8
PRESET/REGEN switch 2-33,
4-19, 4-20
Protecting filter 6-11
Putting on the rain cover 5-30

R
RCP-700 Series 1-6, 5-33, 5-34,
A-7
Real time
 display 4-21
 entering the real time in the
 VITC 4-21
REAL TIME switch 2-34, 4-17,
4-19, 4-22
Recording
 basic procedure 3-5
 cassette tape 3-1, A-6
 checking the recording 3-13
 continuous recording 3-9
 shooting and recording/
 playback functions 2-13
Recording review 3-14
Recording run
 See F-RUN/SET/R-RUN
 switch.
Reference video signal 4-23
REMOTE connector 2-23
Remote control
 connecting a remote control
 unit 5-33
 MSU-700A/750 Master Setup
 Unit 1-6, 2-23, 5-34,
 A-7
 RCP-700 Series Remote
 Control Unit 1-6, 2-23, 5-33,
 5-34, A-7
 RM-B150 Remote Control
 Unit 1-6, 2-23, 5-33, 5-34,
 A-7

RESET button 2-32
RET button 4-21
REW button and indicator 2-25
RF indicator 2-39, 6-14
RM-B150 1-6, 2-23, 5-33, 5-34,
A-7

S

Safety zone marker 2-13
Self-diagnosis
 indicator 4-36
 mode 2-39
SERVO indicator 2-39, 6-14
Setup menu
 basic use 4-31
 DIAGNOSIS menu 4-30
 MAINTENANCE menu 4-30,
 4-85
 OPERATION menu 4-30,
 4-47
 PAINT menu 4-30, 4-72
 TOP menu 4-28
SHIFT button 2-33
Shooting
 See Recording.
Shooting conditions 2-18
Shoulder pad
 adjusting the position 5-29
 feature 2-4
Shoulder strap
 attaching the shoulder strap
 5-27
 shoulder strap posts 2-3

Shutter

 indicator 4-37, 4-49
 ECS mode 4-9
 selecting mode and speed
 4-10
 setting the electronic
 shutter 4-9
 shutter modes 4-9
 standard mode 4-9
 S-EVS mode 4-9, 4-12
SHUTTER selector 2-19
SLACK indicator 2-39, 6-14
Speaker
 operation 2-11
 testing 6-8
Specifications A-1
STOP button 2-26
Storage precautions 1-8
Super Enhanced Vertical definition
System mode
 See S-EVS mode.
S-EVS mode 4-9
Supplied accessories A-6
System configuration 1-6

T

TALLY indicator 2-36
TALLY switch 2-15, 2-36
Tap for measure hook 2-12
TAPE and E indicator 2-38, 6-14

-
- Tape (See also Cassette tape.)
 - remaining tape indicator 2-38, 4-36, 4-49, 6-14
 - testing the tape transport functions 6-6
 - TC IN connector 2-30
 - TC OUT connector 2-30
 - Tele-File 3-16, A-6
 - Testing
 - See Testing the camcorder before shooting.
 - Testing the camcorder before shooting
 - audio level adjusting functions 6-7
 - camera section 6-2
 - earphone 6-8
 - external microphones 6-8
 - iris function 6-5
 - preparations for testing 6-1
 - speaker 6-8
 - tape transport functions 6-6
 - time code function 6-9
 - user bit functions 6-9
 - viewfinder 6-3
 - VTR section 6-6
 - zoom function 6-5
 - Testing the iris and zoom functions 6-5
 - Time code
 - checking 6-9
 - displaying 2-32, 2-40
 - free run mode 2-33
 - free run/recording run switch 2-33
 - preset/regeneration switch 2-33
 - resetting 2-32
 - setting 4-19
 - switch settings and displayed information 2-41
 - synchronizing 4-23
 - time code system 2-29
 - Time counter display 2-40
 - Time data
 - displaying 2-32
 - resetting 2-32, 4-20
 - setting 4-17
 - TOP menu 4-28
 - Tripod
 - adaptor 5-25
 - mount 2-4
 - mounting 5-25
-
- U
- User bits
 - checking 6-9
 - displaying 2-32, 2-40
 - memory 4-18
 - resetting 2-32, 4-18
 - setting 4-17
 - synchronization 4-26
 - Using the supplied microphone 5-14

V

Vertical smear 6-16

Video

head cleaning 6-10

monitor 1-6, 3-14

Viewfinder

adjusting the position 5-7

BKW-401 Rotation

Bracket 1-6, 5-10

cleaning 6-10

detaching 5-9

front-rear positioning lever
2-16, 5-8

indicators on the viewfinder
2-42

left-right positioning ring
2-16, 5-7

operation 2-13

related equipment A-7

selecting display items 4-48

status display 4-34

stopper 2-16, 5-9

testing 6-3

VITC 1-4, 4-18, 4-21, 4-22

VTR

specifications A-3

testing 6-6

operation and status

indicators 2-39

features 1-4

VTR buttons 3-9

VTR SAVE/STBY switch 2-25

VTR START button 2-25

W

WARNING indicator 2-37, 6-14

Warnings and indications

display panel indications
2-39, 6-14

parts and controls 2-35

TALLY indicator 6-14
viewfinder screen displays
6-14

warning sound 2-9, 6-14

warning system 6-14

White balance

adjusting 4-5

error messages 4-8

if you have no time to adjust

the white balance 4-8

memory indicator 4-35, 4-49

memory 4-8

WHITE BAL switch 2-21

WRR-28M/810/860 1-7, 5-22, A-7

Z

Zebra pattern 2-13

ZEBRA switch 2-14

Zoom

position indicator 4-35, 4-49

testing 6-5

Name

Office

Address

Phone

The material contained in this manual consists of information that is the property of Sony Corporation and is intended solely for use by the purchasers of the equipment described in this manual. Sony Corporation expressly prohibits the duplication of any portion of this manual or the use thereof for any purpose other than the operation or maintenance of the equipment described in this manual without the express written permission of Sony Corporation.

Sony Corporation

B & P Company

Printed in Japan

2003.04.13

©2000

HDW-F900 (SY)
3-203-941-**04** (1)

<http://www.sony.net/>
Printed on recycled paper