

Model 2410MD-HSN Monitoring Downconverter Instruction Manual

© Copyright 2001, 2002, 2003

EVERTZ MICROSYSTEMS LTD.

5288 John Lucas Drive,
Burlington, Ontario,
Canada,
L7L 5Z9

Phone: 905-335-3700
Sales Fax: 905-335-3573
Service Fax: 905-335-0909
Internet: Sales: sales@evertz.com
Tech Support: service@evertz.com
Web Page: <http://www.evertz.com>

Version 1.2 October 2003

The material contained in this manual consists of information that is the property of Evertz Microsystems and is intended solely for the use of purchasers of the 2410MD-HSN Monitoring Downconverter. Evertz Microsystems expressly prohibits the use of this manual for any purpose other than the operation of the Downconverter.

All rights reserved. No part of this publication may be reproduced without the express written permission of Evertz Microsystems Ltd. Copies of this guide can be ordered from your Evertz products dealer or from Evertz Microsystems.

INFORMATION TO USERS IN EUROPE

NOTE

CISPR 22 CLASS A DIGITAL DEVICE OR PERIPHERAL

This equipment has been tested and found to comply with the limits for a Class A digital device, pursuant to the European Union EMC directive. These limits are designed to provide reasonable protection against harmful interference when the equipment is operated in a commercial environment. This equipment generates, uses, and can radiate radio frequency energy and, if not installed and used in accordance with the instruction manual, may cause harmful interference to radio communications. Operation of this equipment in a residential area is likely to cause harmful interference in which case the user will be required to correct the interference at his own expense.

INFORMATION TO USERS IN THE U.S.A.

NOTE

FCC CLASS A DIGITAL DEVICE OR PERIPHERAL

This equipment has been tested and found to comply with the limits for a Class A digital device, pursuant to Part 15 of the FCC Rules. These limits are designed to provide reasonable protection against harmful interference when the equipment is operated in a commercial environment. This equipment generates, uses, and can radiate radio frequency energy and, if not installed and used in accordance with the instruction manual, may cause harmful interference to radio communications. Operation of this equipment in a residential area is likely to cause harmful interference in which case the user will be required to correct the interference at his own expense.

WARNING

Changes or Modifications not expressly approved by Evertz Microsystems Ltd. could void the user's authority to operate the equipment.

Use of unshielded plugs or cables may cause radiation interference. Properly shielded interface cables with the shield connected to the chassis ground of the device must be used

REVISION HISTORY

<u>REVISION</u>	<u>DESCRIPTION</u>	<u>DATE</u>
0.1	Preliminary Version	Aug 01
1.0	Added Center Crop downconverter mode	Nov 01
1.1	Change of DIP switch functions, center crop now supported in 720P	Nov 02
1.2	Change of DIP switch functions to enable On Screen Menu Added On Screen Marker controls	Oct 03

Information contained in this manual is believed to be accurate and reliable. However, Evertz assumes no responsibility for the use thereof nor for the rights of third parties, which may be effected in any way by the use thereof. Any representations in this document concerning performance of Evertz products are for informational use only and are not warranties of future performance, either express or implied. The only warranty offered by Evertz in relation to this product is the Evertz standard limited warranty, stated in the sales contract or order confirmation form.

Although every attempt has been made to accurately describe the features, installation and operation of this product in this manual, no warranty is granted nor liability assumed in relation to any errors or omissions unless specifically undertaken in the Evertz sales contract or order confirmation. Information contained in this manual is periodically updated and changes will be incorporated into subsequent editions. If you encounter an error, please notify Evertz Customer Service department. Evertz reserves the right, without notice or liability, to make changes in equipment design or specifications.

This page left intentionally blank

TABLE OF CONTENTS

1.	OVERVIEW.....	1
2.	INSTALLATION.....	2
	2.1. POWER	2
	2.2. VIDEO IN AND OUT	2
	2.3. FIRMWARE UPGRADE PORT	3
3.	SPECIFICATIONS.....	3
	3.1. HD SERIAL VIDEO INPUT	3
	3.2. HD RECLOCKED VIDEO OUTPUT	4
	3.3. SDI SERIAL VIDEO OUTPUTS.....	4
	3.4. ANALOG VIDEO OUTPUTS	4
	3.5. INPUT TO OUTPUT VIDEO PROCESSING DELAY	4
	3.6. ELECTRICAL	5
	3.7. PHYSICAL.....	5
4.	STATUS LED'S.....	5
5.	CARD EDGE CONTROLS	5
	5.1. SELECTING THE OUTPUT VIDEO STANDARD	5
	5.2. SELECTING THE DOWNCONVERTER ASPECT RATIO.....	6
	5.3. SETTING THE NTSC SETUP PEDESTAL ON THE ANALOG OUTPUT.....	6
6.	CONFIGURING THE 2410MD-HSN USING THE ON SCREEN MENU	7
	6.1. TOP LEVEL MENU STRUCTURE	7
	6.2. SETTING THE ON SCREEN MARKER TYPE	8
	6.3. SETTING THE ON SCREEN MARKER OPACITY	8
	6.4. SETTING THE ASPECT RATIO.....	8

7. UPGRADING THE 2410MD-HSN FIRMWARE.....	8
7.1. REQUIREMENTS	9
7.2. UPDATE PROCEDURE	9
7.2.1. Part 1 – Configuring the unit for Firmware upgrades	9
7.2.2. Part 2 – Terminal program Setup	9
7.2.3. Part 3 – Uploading the new firmware	10
7.2.4. Part 4 – Completing the Upgrade.....	10

Figures

Figure 1: 2410MD Block Diagram	1
Figure 2: 2410MD-HSN Module	2

Tables

Table 1: COM Port Pinout	3
Table 2: Video Input Formats	3
Table 3: Input to Output Processing Delay	4
Table 4: DIP Switch Functions	5
Table 5: Output Format Switch Settings.....	6
Table 6: Aspect Ratio Switch Settings	6
Table 7: Analog Output Video NTSC Pedestal Settings	6

1. OVERVIEW

The 2410MD-HSN series Monitoring Down Converter provides an inexpensive method of confidence monitoring your 1.5 Gb/s HDTV signals on standard definition monitors. The 2410MD is ideal to use with your existing standard resolution monitors whether they have analog or component serial digital inputs. The 2410MD-HSN accepts 1080i, 720p, 1080p/24sF, 1080p/25sF (SMPTE 292M) video formats.

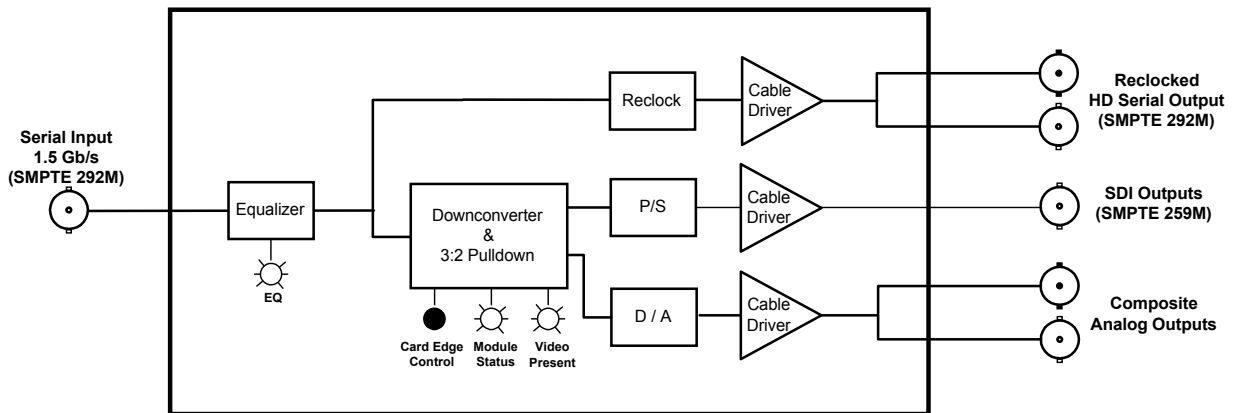

Figure 1: 2410MD Block Diagram

The 2410MD-HSN has colour space conversion from ITU rec. 709 to ITU rec. 601, and will provide various down converted formats such as letterbox, or anamorphic squeeze.

Front panel LEDs indicate signal presence, and CPU and Power Supply health.

Features:

- Center crop, letterbox and anamorphic squeeze down conversion formats
- 1080i/50, 1080i/60, 720p/60, 1080p/24sF, 1080p/25sF
- Auto video standard detection
- 4 position DIP switch selects Input Format and Down-converted format
- On screen markers show 4:3 aspect ratio and safe area
- ITU rec. 709 to ITU rec. 601 colour space conversion

2. INSTALLATION

The 2410MD-HSN is a compact module that has six BNC connectors and a 9 pin Female D connector serial port for firmware upgrades.

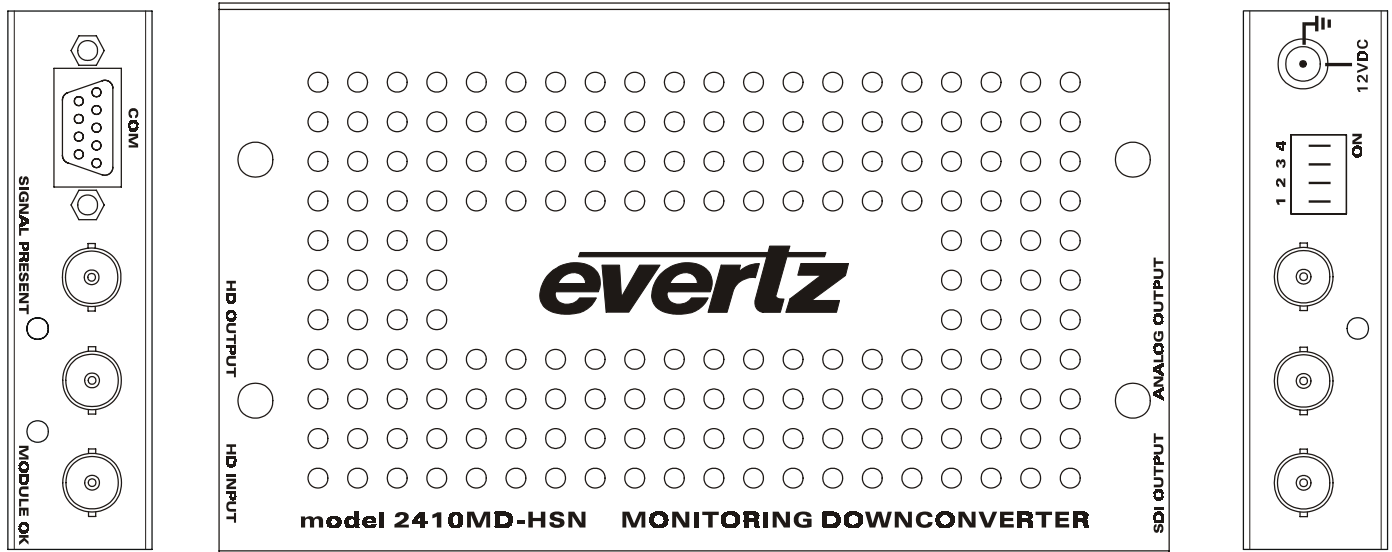

Figure 2: 2410MD-HSN Module

2.1. POWER



The 2410MD-HSN comes with an auto-ranging DC voltage adapter that automatically senses the input voltage. Power should be applied by connecting a 3-wire grounding type power supply cord to the power entry module on the DC voltage adapter. The power cord should be minimum 18 AWG wire size; type SST marked VW-1, maximum 2.5 m in length. The DC cable of the voltage adapter should be connected to the DC power jack on the rear panel. A green MODULE OK LED located beside the HD INPUT connector will be illuminated when there is power applied to the 2410MD-HSN and the processor is operating properly.

2.2. VIDEO IN AND OUT

HD INPUT Input BNC connector for 10-bit serial digital video signals, compatible with the SMPTE 292M standard. The 2410MD-HSN automatically selects the video standard.

HD OUTPUT These two BNC connectors are used to output a reclocked copy of the input video.

SDI OUTPUT This BNC connector is used to output the downconverted input video as serial component video, compatible with the SMPTE 259M standard. Table 3 shows the output video format for each input video standard supported.

ANALOG OUTPUT These two BNC connectors are used to output the downconverted input video as analog composite video. Table 3 shows the output video format for each input video standard supported.

2.3. FIRMWARE UPGRADE PORT

The **COM** connector is a female 9 pin D connector used for connecting a computer to upload firmware to the 2410MD-HSN. Table 1 shows the pinout of the male high density DB-15 connector. See section 6 for information on upgrading the firmware in the 2410MD-HSN.

Pin #	Name	Description
1		
2	TxD	RS-232 Transmit Output
3	RxD	RS-232 Receive Input
4		
5	Sig Gnd	RS-232 Signal Ground
6		
7		
8		
9		

Table 1: COM Port Pinout

3. SPECIFICATIONS

3.1. HD SERIAL VIDEO INPUT

Standard: 1.485 Gb/sec SMPTE 292M – autodetect
Connector: BNC per IEC 60169-8 Amendment 2.
Equalization: Automatic to 65m @ 1.5Gb/s with Belden 1694 or equivalent cable

Common Name	Pixels / Active Lines	Frame Rate	Progressive /Interlace	SMPTE Standard
1080i/60	1920 x 1080	30	I	274M
1080i/59.94	1920 x 1080	29.97 (30/1.001)	I	274M
1080i/50	1920 x 1080	25	I	274M
1080p/25sF	1920 x 1080	25	P (sF)	RP211
1080p/24sF	1920 x 1080	24	P (sF)	RP211
1080p/23.98sF	1920 x 1080	23.98 (24/1.001)	P (sF)	RP211
720p/60	1280 x 720	60	P	296M
720p/59.94	1280 x 720	59.94 (60/1.001)	P	296M

Table 2: Video Input Formats

3.2. HD RECLOCKED VIDEO OUTPUT

Standard:	Same as input
Connectors:	2 BNC per IEC 60169-8 Amendment 2.
Signal Level:	800mV nominal
DC Offset:	0V \pm 0.5V
Rise and Fall Time:	200ps nominal
Overshoot:	<10% of amplitude
Wide Band Jitter:	< 0.15 UI

3.3. SDI SERIAL VIDEO OUTPUTS

Standards:	serial component 270 Mb/s (SMPTE 259M-C)
Connectors:	1 BNC per IEC 60169-8 Amendment 2.
Signal Level:	800mV nominal
DC Offset:	0V \pm 0.5V
Rise and Fall Time:	470ps nominal
Overshoot:	<10% of amplitude
Return Loss:	> 15 dB
Wide Band Jitter:	< 0.15 UI

3.4. ANALOG VIDEO OUTPUTS

Number of Outputs:	2
Standards:	Analog composite NTSC if input is 1080i/60, 1080i/59.94, 1080p/24sF, 1080p/23.98sF, 720p/60 or 720p/59.94 Analog composite PAL if input is 1080i/50, 1080p/25sF or 1080p/24sF
Connectors:	2 BNC per IEC 60169-8 Amendment 2.
Signal Level:	1 V p-p nominal
DC Offset:	0V \pm 0.1V
Return Loss:	> 45 dB up to 6 MHz

3.5. INPUT TO OUTPUT VIDEO PROCESSING DELAY

The delay between the input HD video's line 1 and the downconverted output video's line 1 is 50 lines of the SD video when the incoming and outgoing frame rate is the same. Then the incoming frame rate is 24 (23.98) there is an additional frame of delay.

Input Video	Output Video	Delay (lines)	Delay (ms)
1080i/59.94	525i/59.94	50	3.17
1080i/50	625i/50	50	3.2
1080p/25	625i/50	50	3.2
1080p/23.98	525i/59.94	706	44.87
1080p/24	625i/50	701	44.86
720p/59.94	525i/59.94	50	3.17

Table 3: Input to Output Processing Delay

3.6. ELECTRICAL

Voltage: Nominal + 12VDC (Maximum 18V)
Power: 10 watts
EMI/RFI: Complies with FCC regulations for class A devices.
Complies with EU EMC directive.

3.7. PHYSICAL

Dimensions: 6" L x 4" W x 1" H
(152mm L x 114mm W x 25mm H)
Weight: 0.5 lbs. (0.28 Kg)

4. STATUS LED'S

MODULE OK This Green LED will be On when the module powered up and processor is functioning with operating limits.

SIGNAL PRESENT: This Green LED will be On when there is a supported video signal present at the module input.

5. CARD EDGE CONTROLS

The 2410MD-HSN is equipped with a 4 position DIP switch, located on one end of the unit, to allow the user to select various down converted output formats. Table 4 gives an overview of the DIP switch functions. The On position is closest to the camera body.

DIP Switch	Function
1	Output Video Standard
2	Downconverter Aspect Ratio Format
3	
4	Output Pedestal

Table 4: DIP Switch Functions

5.1. SELECTING THE OUTPUT VIDEO STANDARD

DIP switch 1 is used to set the downconverted output video standard. Refer to the following table to set the output format. The 2410MD-HSN will insert extra fields of some frames to create a 3:2 or 24:25 pulldown on the output video when 23.98 sF or 24 sF video is input. The relationship of the pulldown sequence to the input video will be random. For other input formats, the 2410MD-HSN will insert or remove fields of some frames to create the correct number of output frames.

Input	DIP 1 ON	DIP 1 OFF
1080i/60	625i/50 (PAL)	525i/60
1080i/59.94	INVALID OUTPUT	525i/59.94 (NTSC)
1080i/50	625i/50 (PAL)	525i/60
1080p/25sF	625i/50 (PAL)	525i/60
1080p/24sF	625i/50 (PAL)	525i/60
1080p/23.98sF	INVALID OUTPUT	525i/59.94 (NTSC)
720p/60	625i/50 (PAL)	525i/60
720p/59.94	INVALID OUTPUT	525i/59.94 (NTSC)

Table 5: Output Video Standard Switch Settings**5.2. SELECTING THE DOWNCONVERTER ASPECT RATIO**

DIP switches 2 and 3 are used to select one of three aspect ratio down conversion formats, and to enable the On Screen Menu.

DIP 2	DIP 3	Down converted Aspect Ratio Format
Off	Off	Letter Box
On	Off	Center crop
Off	On	4x3 Squeeze
On	On	On Screen Menu Enabled

Table 6: Aspect Ratio Switch Settings

When DIP switches 2 and 3 are both set to the On position the aspect ratio is set using the On Screen Menu system. There are also additional configuration items available using the on screen menu system. See section 6.

5.3. SETTING THE NTSC SETUP PEDESTAL ON THE ANALOG OUTPUT

DIP switch 4 is used to select the whether the NTSC Setup Pedestal will be applied on the Analog Output. The NTSC setup pedestal should not be present when operating in Japan.

DIP 4	Output Pedestal
Off	Pedestal inserted
On	No pedestal

Table 7: Analog Output Video NTSC Pedestal Settings

6. CONFIGURING THE 2410MD-HSN USING THE ON SCREEN MENU

An On screen menu (OSD) is used to configure several of the 2410MD-HSN's parameters. The three position, return to center, toggle switch and momentary pushbutton located on the side of the unit are used to navigate the OSD setup menus and configure the cards various controls.

To enter the OSD menu system, set DIP switches 2 and 3 to the On (Closed) position. Then press the pushbutton. This will bring you to the main setup menu where you can use the toggle switch to move up and down the list of available sub menus. An arrow (>) moves up and down the left hand side of the menu items to indicate which item you are currently choosing. Once the arrow is on the desired item, press the pushbutton to select the next menu.

On all menus, there is a selectable item *Done*. Selecting *Done* will exit the OSD menu and return the 2410MD-HSN to the normal operating mode.

Use the toggle switch to move up or down to the desired parameter and press the pushbutton. The arrow will move to the right hand side (<) indicating that you can now adjust the parameter. Using the toggle switch, adjust the parameter to its desired value.

When you have stopped at the desired value, depress the pushbutton. This will update the parameter with the selected value and move the arrow back to the left side of the parameter list. Continue selecting and adjusting other parameters or use the *Done* command to exit the OPD menu.

6.1. TOP LEVEL MENU STRUCTURE

The following is a brief description of the top level of the menu tree that appears when you enter the On screen menu. Selecting one of these items will take you down into the next menu level.

<i>Marker Type</i>	Sets the type of on screen marker
<i>Marker Opacity</i>	Sets the opacity of the on screen markers.
<i>Aspect Ratio</i>	Sets the aspect ratio of the downconverted output.
<i>Done</i>	Exit On Screen Menu System

6.2. SETTING THE ON SCREEN MARKER TYPE

Marker Type
No marker
4:3 Line
4:3 Shaded
Safe Action
4:3 Line with center

With this control, you can select the type of On screen markers.

Select *No Marker* to turn the On Screen markers off.

Select *4:3 Line* to display On Screen markers with vertical lines at the 4:3 aspect ratio of the original image.

Select *4:3 Shaded* to display On Screen markers with areas outside the 4:3 aspect ratio of the original image shaded.

Select *Safe Action* to display On Screen markers with a box at the safe action areas of the original image.

Select *4:3 Line with center* to display On Screen markers with vertical lines at the 4:3 aspect ratio and a cross at the center of the original image.

6.3. SETTING THE ON SCREEN MARKER OPACITY

Marker Opacity
25 percent
50 percent
75 percent
100 percent

With this control, you can select the opacity of the On screen markers.

6.4. SETTING THE ASPECT RATIO

Aspect Ratio
Letterbox
4:3 Center Crop
4:3 Squeeze

With this control, you can select the aspect ratio of the downconverted picture.

7. UPGRADING THE 2410MD-HSN FIRMWARE

The 2410MD-HSN module contains firmware that is contained in a FLASH EPROM device. From time to time firmware updates will be provided to add additional features to the unit. The 2410MD-HSN module is fitted with a COM port connector that can be connected to a PC with a straight through cable. The following procedure will allow you to upload new firmware from your computer.

7.1. REQUIREMENTS

You will need the following equipment in order to update the 2410MD-HSN Firmware

- PC with available communications port. The communication speed is 57600 baud, therefore a 486 PC or better with a 16550 UART based communications port is recommended.
- “Straight-thru” serial extension cable (DB9 female to DB9 male) or (DB25 female to DB9 male)
- Terminal program that is capable of Xmodem file transfer protocol. (such as HyperTerminal)
- New firmware supplied by Evertz.

7.2. UPDATE PROCEDURE

7.2.1. Part 1 – Configuring the unit for Firmware upgrades

1. Connect the 9 pin male connector on the straight through serial extension cable to the COM port on the end of the 2410MD-HSN. Connect the 9 pin female connector to the PCs’ RS-232 communications port

7.2.2. Part 2 – Terminal program Setup

2. Start the terminal program.
3. Configure the port settings of the terminal program as follows:

Baud	57600
Parity	no
Data bits	8
Stop bits	2
Flow Control	None

4. Apply power to the 2410MD-HSN. After the unit powers up, a banner with the boot code version information should appear in the terminal window. The cursor to the right of the word “BOOT>” should be spinning for about 5 seconds then the unit will continue to boot.

For example:

```
EVERTZ 7700PB MONITOR 1.0  
COPYRIGHT 1997, 1998, 1999 EVERTZ MICROSYSTEMS LTD.  
COLD BOOT |
```

5. The following is a list of possible reasons for failed communications:

- Defective 2410MD-HSN Serial Upgrade cable.
 - Wrong communications port selected in the terminal program.
 - Improper port settings in the terminal program. (Refer to step 7 for settings).
6. While the cursor is spinning press the <CTRL> and <X> keys on your computer keyboard at the same time, this should stop the cursor from spinning. The spinning prompt will only remain for about 5 seconds. You must press <CTRL-X> during this 5 second delay. If the unit continues to boot-up, simply cycle the power and repeat this step.
 7. Hit the <ENTER> key on your computer once.
 8. Type the word “upgrade”, without quotes, and hit the <ENTER> key once.

9. The boot code will ask for confirmation. Type "y", without quotes.
10. You should now see a prompt asking you to upload the file.

7.2.3. Part 3 – Uploading the new firmware

11. Upload the "*.bin" file supplied using the X-Modem transfer protocol of your terminal program. If you do not start the upload within 10 minutes the 2410MD-HSN Boot code will time out. You can restart the upgrade process by removing and reinstalling the module.
12. The boot code will indicate whether the operation was successful upon completion of the upload.

For Example:

```
UPLOAD OKAY
7700PB COLD BOOT> |
```

13. The following is a list of possible reasons for a failed upload:
 - If you get the message "transfer cancelled by remote" you must restart the terminal program and load the bin file, then remove and install the module again.
 - The supplied "*.bin" file is corrupt.
 - Wrong file specified to be uploaded.
 - The PCs' RS-232 communications port can't handle a port speed of 57600.
 - Noise induced into the 2410MD-HSN Serial Upgrade cable.

7.2.4. Part 4 – Completing the Upgrade

14. Type the word "boot", without quotes, and hit the <ENTER> key once or power cycle the unit. The unit should now reboot.
15. You can now close the terminal program and disconnect the serial cable.

The update procedure is now completed.