

SONY®

DIGITAL CINEMATOGRAPHY CAMERA

F35



OPERATION MANUAL
1st Edition (Revised 2)

English

WARNING

To reduce the risk of fire or electric shock, do not expose this apparatus to rain or moisture.

To avoid electrical shock, do not open the cabinet. Refer servicing to qualified personnel only.

For the customers in the U.S.A.

This equipment has been tested and found to comply with the limits for a Class A digital device, pursuant to Part 15 of the FCC Rules. These limits are designed to provide reasonable protection against harmful interference when the equipment is operated in a commercial environment. This equipment generates, uses, and can radiate radio frequency energy and, if not installed and used in accordance with the instruction manual, may cause harmful interference to radio communications. Operation of this equipment in a residential area is likely to cause harmful interference in which case the user will be required to correct the interference at his own expense.

You are cautioned that any changes or modifications not expressly approved in this manual could void your authority to operate this equipment.

All interface cables used to connect peripherals must be shielded in order to comply with the limits for a digital device pursuant to Subpart B of Part 15 of FCC Rules.

For the customers in Europe

This product with the CE marking complies with the EMC Directive issued by the Commission of the European Community.

Compliance with this directive implies conformity to the following European standards:

- EN55103-1: Electromagnetic Interference (Emission)
- EN55103-2: Electromagnetic Susceptibility (Immunity)

This product is intended for use in the following Electromagnetic Environments: E1 (residential), E2 (commercial and light industrial), E3 (urban outdoors), E4 (controlled EMC environment, ex. TV studio).

The manufacturer of this product is Sony Corporation, 1-7-1 Konan, Minato-ku, Tokyo, Japan.

The Authorized Representative for EMC and product safety is Sony Deutschland GmbH, Hedelfinger Strasse 61, 70327 Stuttgart, Germany. For any service or guarantee matters please refer to the addresses given in separate service or guarantee documents.

For the State of California, USA only

Perchlorate Material - special handling may apply, See www.dtsc.ca.gov/hazardouswaste/perchlorate
Perchlorate Material : Lithium battery contains perchlorate.

For the customers in Taiwan only



廢電池請回收

AVERTISSEMENT

Afin de réduire les risques d'incendie ou d'électrocution, ne pas exposer cet appareil à la pluie ou à l'humidité.

Afin d'écartier tout risque d'électrocution, garder le coffret fermé. Ne confier l'entretien de l'appareil qu'à un personnel qualifié.

Pour les clients en Europe

Ce produit portant la marque CE est conforme à la Directive sur la compatibilité électromagnétique (EMC) émise par la Commission de la Communauté européenne.

La conformité à cette directive implique la conformité aux normes européennes suivantes :

- EN55103-1 : Interférences électromagnétiques (émission)
- EN55103-2 : Sensibilité électromagnétique (immunité)

Ce produit est prévu pour être utilisé dans les environnements électromagnétiques suivants : E1 (résidentiel), E2 (commercial et industrie légère), E3 (urbain extérieur) et E4 (environnement EMC contrôlé, ex. studio de télévision).

Le fabricant de ce produit est Sony Corporation, 1-7-1 Konan, Minato-ku, Tokyo, Japon.

Le représentant autorisé pour EMC et la sécurité des produits est Sony Deutschland GmbH, Hedelfinger Strasse 61, 70327 Stuttgart, Allemagne. Pour toute question concernant le service ou la garantie, veuillez consulter les adresses indiquées dans les documents de service ou de garantie séparés.

WARNUNG

Um die Gefahr von Bränden oder elektrischen Schlägen zu verringern, darf dieses Gerät nicht Regen oder Feuchtigkeit ausgesetzt werden.

Um einen elektrischen Schlag zu vermeiden, darf das Gehäuse nicht geöffnet werden. Überlassen Sie Wartungsarbeiten stets nur qualifiziertem Fachpersonal.

Für Kunden in Europa

Dieses Produkt besitzt die CE-Kennzeichnung und erfüllt die EMV-Richtlinie der EG-Kommission.

Angewandte Normen:

- EN55103-1: Elektromagnetische Verträglichkeit (Störaussendung)
- EN55103-2: Elektromagnetische Verträglichkeit (Störfestigkeit), für die folgenden elektromagnetischen Umgebungen: E1 (Wohnbereich), E2 (kommerzieller und in beschränktem Maße industrieller Bereich), E3 (Stadtbereich im Freien) und E4 (kontrollierter EMV-Bereich, z.B. Fernsehstudio).

Der Hersteller dieses Produkts ist Sony Corporation, 1-7-1 Konan, Minato-ku, Tokyo, Japan.

Der autorisierte Repräsentant für EMV und Produktsicherheit ist Sony Deutschland GmbH, Hedelfinger Strasse 61, 70327 Stuttgart, Deutschland. Bei jeglichen Angelegenheiten in Bezug auf Kundendienst oder Garantie wenden Sie sich bitte an die in den separaten Kundendienst- oder Garantiedokumenten aufgeführten Anschriften.

Table of Contents

Chapter 1 Overview

1-1 Features	8
1-2 Example of System Configuration	10
1-2-1 SRW-1 Docking System	11
1-2-2 Optical Fiber System Using the CA-F101	11
1-3 Locations and Functions of Parts	12
1-3-1 Camera Head	12
1-3-2 Assistant Panel (Supplied)	17
1-3-3 Interface Box (Supplied)	17

Chapter 2 Installation and Preparations

2-1 Mounting the Interface Box	19
2-2 Mounting the SRW-1 Recorder	21
2-3 Mounting the CA-F101 and Optical Connection	22
2-4 Attaching a Lens	23
2-5 Attaching a Viewfinder	24
2-6 Mounting the Camera to a Tripod	25
2-7 Attaching/Detaching Handles	26
2-7-1 L Handle	26
2-7-2 Center Handle (Supplied)	26
2-8 Preparing the Power Supply	27
2-9 Setting the Built-in Clock	28

Chapter 3 Basic Adjustments and Settings

3-1 Selection of the Basic Operation Modes	30
3-1-1 Overview of the Basic Operation Modes	30
3-1-2 Switching of the Basic Operation Modes	30
3-2 Basic Settings with the Subdisplay	32
3-2-1 Basic Operation of the Subdisplay	32
3-2-2 Shutter Settings	33
3-2-3 RAMP Operation	35
3-2-4 Selection of Video Formats	35
3-2-5 Retrieving the ND Offset	36
3-2-6 Selection of the Gain, Color Temperature, and White Balance Memory	36

3-2-7	Selection of a Lens File	37
3-2-8	Confirmation of the Time Code and Tape Remaining ...	38
3-2-9	Confirmation of the Power Voltage and Selection of Fan Operation Mode	38
3-2-10	ON/OFF of the Character Indication	39
3-2-11	Allocation of Functions to the Assignable Buttons and Switch	39
3-2-12	Brightness Adjustment of the Subdisplay	40
3-2-13	Selection of Gamma Tables	40
3-2-14	Selection of Color Spaces	40
3-2-15	Checking the Optical Levels	40
3-2-16	Limiting Pages that are Displayed on the Subdisplay ..	40
3-3	Black Balance Adjustment	42
3-4	White Balance Adjustment (in Custom mode)	42
3-5	Setting the Camera Outputs	44
3-5-1	Selecting a Video Output Signal for Each Connector ...	44
3-5-2	Setting the Monitor Picture	44
3-5-3	Outputting Color Bars	46
3-6	Viewing and Setting the Viewfinder Displays	47
3-6-1	Viewing the Basic Status Indications	47
3-6-2	Viewing the ABNORMAL <!> Display	48
3-6-3	Viewing the FUNCTION (Format/Switch Function) Display	49
3-6-4	Setting the Marker Indications	49
3-6-5	Adjusting the Viewfinder Details	50
3-6-6	Setting the Zebra Indication	51
3-6-7	Setting the Cursor Indication	51
3-6-8	Checking the Power Voltage	52
3-7	Detailed Settings of the Switch Functions	53
3-8	Setting the Gain	54
3-9	Detailed Shutter Settings	54
3-10	Resuming the Standard Conditions	56
3-11	Selecting the Gamma	56
3-11-1	Using the Standard Gamma	56
3-11-2	Using the Hyper Gamma	57
3-11-3	Using the S-LOG	57
3-11-4	Using the User Gamma	57
3-12	Inverting the Camera Picture	58
3-13	Detailed Setting of the Video Format	59

Chapter 4 Menu Configuration and Detailed Settings

4-1 Menu Configuration	60
4-2 Basic Menu Operations	61
4-2-1 Displaying Setting Pages	62
4-2-2 Setting the Menu Items	63
4-3 Menu List	64
4-3-1 OPERATION Menu	64
4-3-2 PAINT Menu	71
4-3-3 MAINTENANCE Menu	78
4-3-4 NETWORK Menu	84
4-3-5 FILE Menu	85
4-3-6 DIAGNOSIS Menu	89
4-4 Editing the USER Menu	90

Chapter 5 Storage and Retrieval of User Setting Data

5-1 File Configuration	93
5-2 List of Items Stored in Files	95
5-3 File Operations	96
5-3-1 Using a “Memory Stick”	96
5-3-2 Storage and Retrieval of the Operator File	97
5-3-3 Registration and Retrieval of the Lens Files	98
5-3-4 Storage and Retrieval of the Scene Files	98
5-3-5 Storage and Retrieval of the Reference File	99
5-3-6 Reading of the User Gamma	100
5-3-7 Storage of the OHB File	100
5-3-8 Resetting to the Initial Settings	101

Appendixes

Using the RM-B750	102
Connection	102
Operating the Menu of This Camera	102
Monitoring the Camera Image	103
Using the MSU-900/950	103
Connections	103
Parameter Settings	104
Using the ARRI Remote Control	106
About Metadata	107
Warning/Error Messages	114
Precautions	115

About a “Memory Stick”	116
Specifications	118
Camera Head	118
Interface Box (Supplied)	120
Optional Accessories	120
Connector Pin Assignments	121
Color Space According to the COLOR SPACE	
Settings	123
Lip Sync Compensation	124
Index	126

1-1 Features

The F35 is a 1CCD digital cinematography camera equipped with Super 35-mm type IT progressive CCD array with a total of 6,600,000 picture elements (effective pixel count of 1920 [H] × 1080 [V] RGB).

The camera is incorporated with newly developed imagers and a digital signal-processing LSI that yield images of a high quality for cinematic, commercial, and dramatic production applications. The camera also supports the features of a “production camera” up to details in its shape, button and indicator layout, and materials of the parts.

Superior Picture Quality and High Performance

Super 35-mm type CCD and PL Mount

With the F35’s Super 35-mm-type CCD imagers and PL Mount, most movie lenses designed for conventional 35-mm film cameras can be mounted without a converter.

Wide dynamic range and high-quality digital pictures

With its newly developed imagers, 14-bit A/D converter, and unique digital LSI, the camera achieves significant extension of the dynamic range and picture quality of optimal grade, minimizing noises.

RGB 4:4:4 image capturing

The RGB 4:4:4 image-capturing capability, having high affinity with computer graphics, yields significant results, especially in chroma-keying and color-correction processes where highly exacting special-effects sequences and elaborate finishes are required in demanding movie-making, commercial, and television applications.

Variable-speed recording

When used with a Sony SRW-1 HD Portable Digital Recorder, the number of frames per second (FPS) for shooting/recording is selectable in single-frame increments. This allows users to create slow- or fast-motion effects equivalent to those obtained by

“overcranking” or “undercranking” a cinematic film camera.

Frame-rate settings for this function are variable from 1 to 50 FPS.

Multiple frame formats

The camera covers the 1080 formats of different types to allow it to be used for high-end content creation, including commercial and broadcasting program production as well as movie making.

- Progressive mode: 1080/23.98P, 1080/24P, 1080/25P, 1080/29.97P, 1080/50P
- Progressive mode (variable): 1080/S23.98P, 1080/S24P, 1080/S29.97P, 1080/S50P, 1080/S59.94P (MAX50), 1080/S60P (MAX50)
- Interlace mode: 1080/50i, 1080/59.94i

Imaging characteristics with wide color space

Sony’s unique technology allows the camera to capture images in natural-looking colors closer to those of the actual scene than with conventional cameras.

S-LOG and Hyper gammas

S-LOG and Hyper gammas, field-proven in Sony’s F23 digital cinematography camera and HDW-F900R HD digital camcorder, are included among the standard selections with the F35.

User Gamma

The F35 allows you to customize gamma curves according to your creative needs, using the CvpFileEditor¹⁾ application software.

1) You can download the software from the “eCSite,” the site for downloading business and professional software from Sony Corporation.

Design and Shape

New compact design

For a high level of mobility in consideration of various shooting situations, such as inside a car, the camera is housed in as compact a body as possible. In addition, buttons and indicators are laid out to provide a familiar and intuitive user interface to users of conventional cinema film cameras.

Dockable system of the SRW-1 HD Portable Digital Recorder

A dockable interface system is employed to conform to versatile shooting conditions and on-site demands. The SRW-1¹⁾ can be docked directly on the top or rear of the camera, as required for shooting conditions. The camera and SRW-1 recorder can also be tethered via cables to take advantage of the compactness of the camera for higher mobility.

1) The firmware of the SRW-1 may be required to be updated for use with the camera. For details, consult your local Sony representative.

Compatible with film-camera accessories

The F35 is designed to be compatible with a variety of film-camera accessories, giving users a broad array of choices. These include ARRIFLEX-made bridge plates, matte boxes, follow focus units, lens focus/zoom/iris servo control units, and more. These film-camera accessories can be attached to the F35 without modification, enabling users who principally work with film to fully utilize their assets.

Having one 12 V DC output connector and another 24 V DC¹⁾ output connector, the F35 can supply power to such compatible accessories attached to it through these connectors.

1) To feed 24 V DC power in synchronization with the power switch of the camera, an independent power supply of 24V DC is required in addition to the 12 V power.

Assignable switches

Functions frequently used in the field, such as optical filter switching, can be assigned to three push buttons and one switch located on the side panel of the camera, allowing the operator to make rapid changes when working in the field.

Saving/retrieving settings with a “Memory Stick”¹⁾

Using a “Memory Stick,” you can save menu settings for particular shooting conditions for retrieval when required.

1) Memory Stick and  MEMORY STICK™ are trademarks of Sony Corporation.

Operational Versatility

Two operation modes: Cine and Custom

The F35 offers two operation modes; “Cine Mode” for movie-making applications, where image tone is normally adjusted in post production, and “Custom Mode,” which is suitable for users who wish to fine-tune camera parameters to produce their desired look in on-set grading.

Shutter control

When using the electronic shutter, the setting indication can be switched between the shutter angle (degree) and shutter speed (second).

Monitor output selection

For monitor outputs, the user can select flexibly whether to mix character information and markers, whether to apply alternative monitor gamma other than that applied to the camera signal, or how to mix the playback picture.

Image inversion function

The image inversion function, field-proven in Sony’s F23 digital cinematography camera and HDW-F900R HD digital camcorder, is included among the standard functions with the F35.

The delay of video relative to audio may vary according to the ON/OFF setting of this function (*see page 124*).

Other Features

Assistant panel

The supplied assistant panel has an identical button and indicator layout to that of the on-camera control panel and provides intuitive remote control of basic camera operations, such as control of frame rate (fps), shutter (indication in angles enabled), gain, color temperature (switching between Tungsten and Daylight enabled), timecode/tape remaining check, character indications, and function assignment to the assignable buttons.

Down-conversion output

The down-converter built into the camera as standard equipment enables camera pictures as well as VTR playback pictures to be monitored using a conventional SD monitor.

Twin-viewfinder operation

Two viewfinders can be attached to the F35 for simultaneous monitoring with different settings of character information and marker indications.

1-2 Example of System Configuration

The diagram below shows a system configuration example to use of this camera.

In this manual, an optional HDVF-C35W HD Electronic Viewfinder is used to instruct how to operate the unit.

For more information about the fittings, connections, or use of additional equipment and accessories, see "Chapter 2 Installation and Preparations" as well as the operation manuals for the connected equipment.

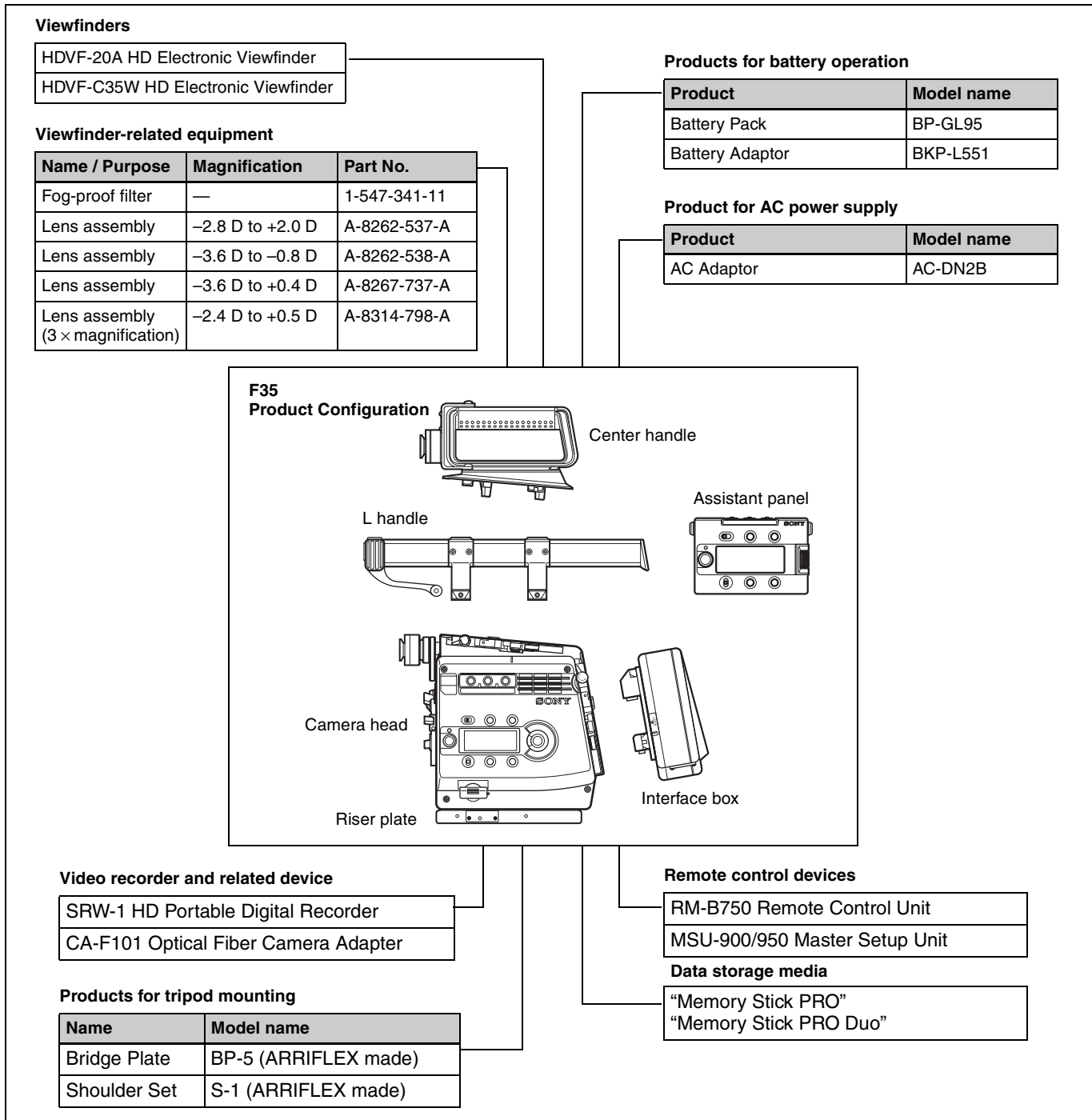

Note

When using the SRW-1, CA-F101, or a control device, such as an RM-B750, in combination with this camera, you must check each of their versions.

Consult a Sony representative for information about these versions.

1-2-1 SRW-1 Docking System

An SRW-1 recorder can be mounted either on the top or rear of the camera head. Power can also be supplied to the recorder via the DC IN connector (LEMO 8-pin) of the camera head.

Upper docking

The interface box can be attached to the rear.

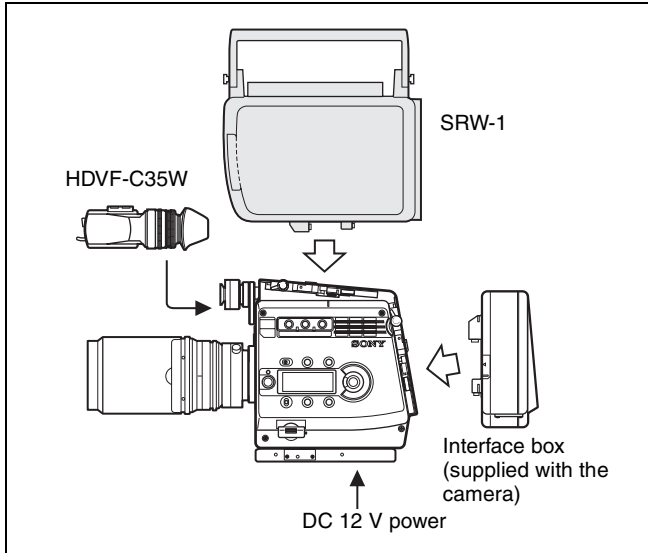

Rear docking

The interface box can be attached to the top.

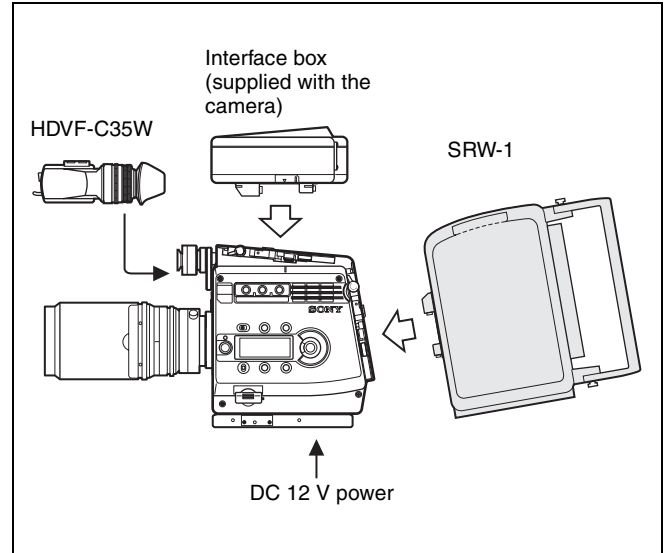

1-2-2 Optical Fiber System Using the CA-F101

Attaching an optional CA-F101 Optical Fiber Camera Adapter to the camera enables signal transmission and interface between the camera and the SRW-1 HD Portable Digital Recorder/SRPC-1 HD Video Processor with the HKSR-101 Optical Interface Unit via a hybrid optical camera cable.

For this system, independent power supply to both the camera and the recorder is required. Attaching the CA-F101 to the top and the interface unit to the rear is also allowed.

For details, refer to the Operation Manual of the CA-F101.

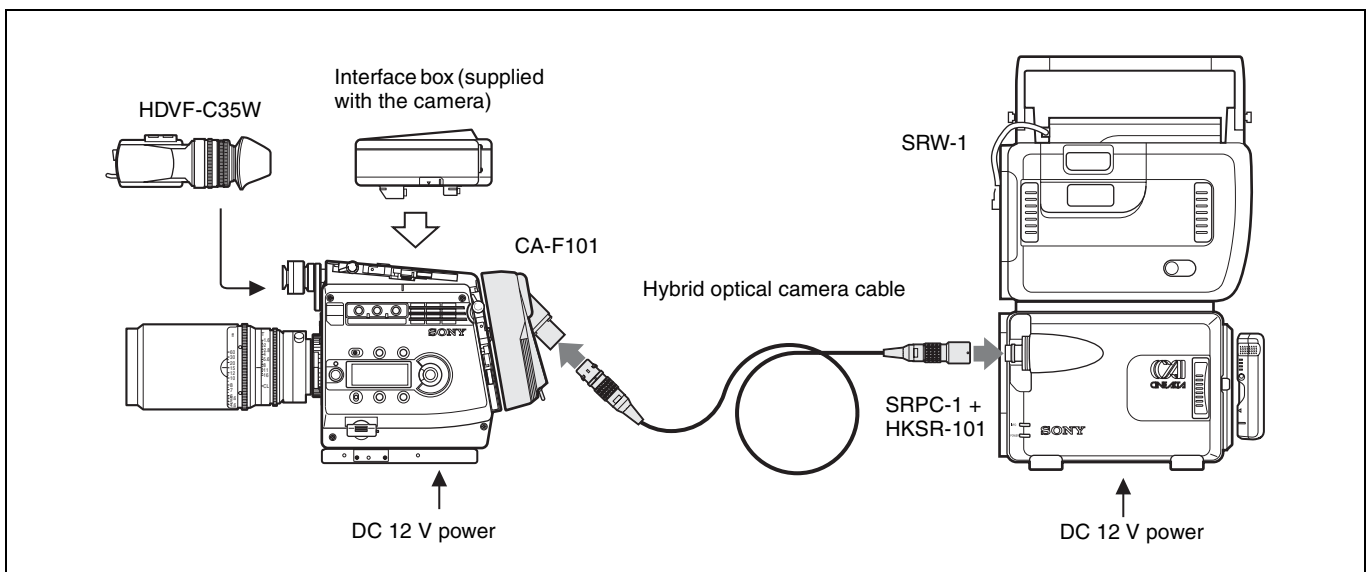

1-3 Locations and Functions of Parts

1-3-1 Camera Head

Front panel

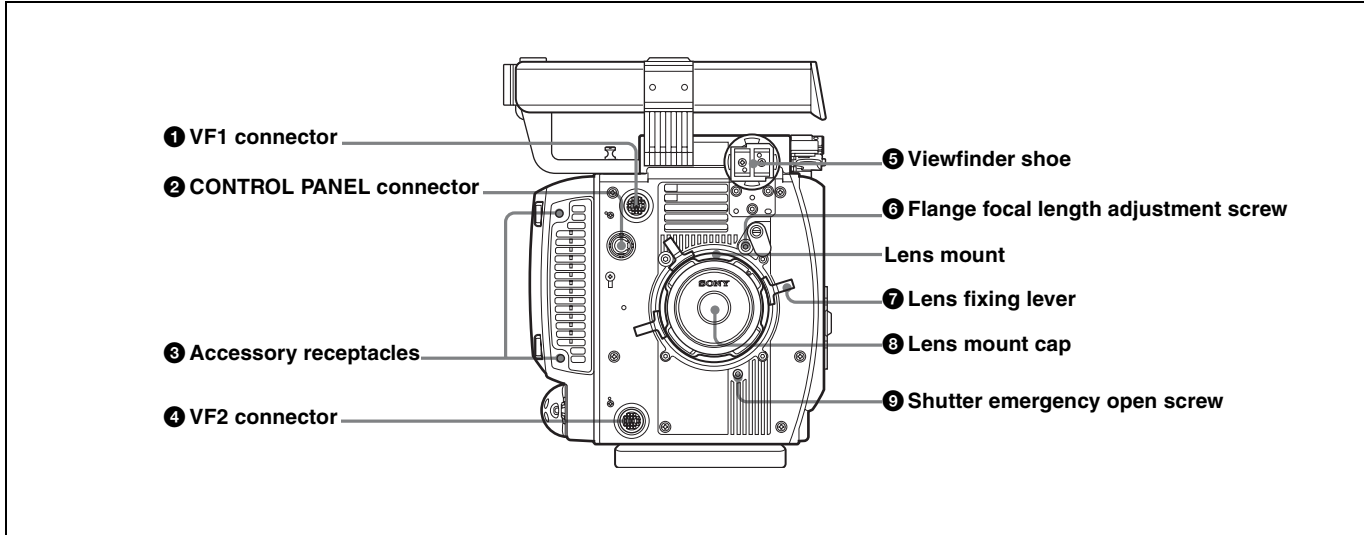

1 VF1 (viewfinder 1) connector (20-pin)

Connect a viewfinder (optional).

2 CONTROL PANEL connector

Connect with the CAMERA connector of the supplied assistant panel (page 17).

3 Accessory receptacles

Using these screw holes in combination with the accessory pockets (page 13) on the left side, you can fix a certain accessory to the left side of the camera.

4 VF2 (viewfinder 2) connector (20-pin)

Connect a second viewfinder (optional), e.g. for an assistant.

Note

When two viewfinders are connected at the same time (via the VF1 and VF2 connectors), the HDVF-C950W cannot be used because of a limitation of current capacity.

5 Viewfinder shoe

Attach an optional viewfinder.

The height of the attaching position can be adjusted.

For details, see “2-5 Attaching a Viewfinder” (page 24).

6 Flange focal length adjustment screw

You can adjust the flange focal length with the screw behind the cover.

For details, see “Adjusting the flange focal length” (page 23).

7 Lens fixing lever

Turn the lever clockwise to secure the lens in the lens mount. To remove the lens, turn the lever counterclockwise.

For details, see “2-4 Attaching a Lens” (page 23).

8 Lens mount cap

Cover the lens mount with this cap when a lens is not attached. The cover may be removed by rotating the lens fixing lever counterclockwise.

9 Shutter emergency opening screw

You can forcibly open the shutter in an emergency.

For details, see “To forcibly open the shutter” on page 115.

Left panel

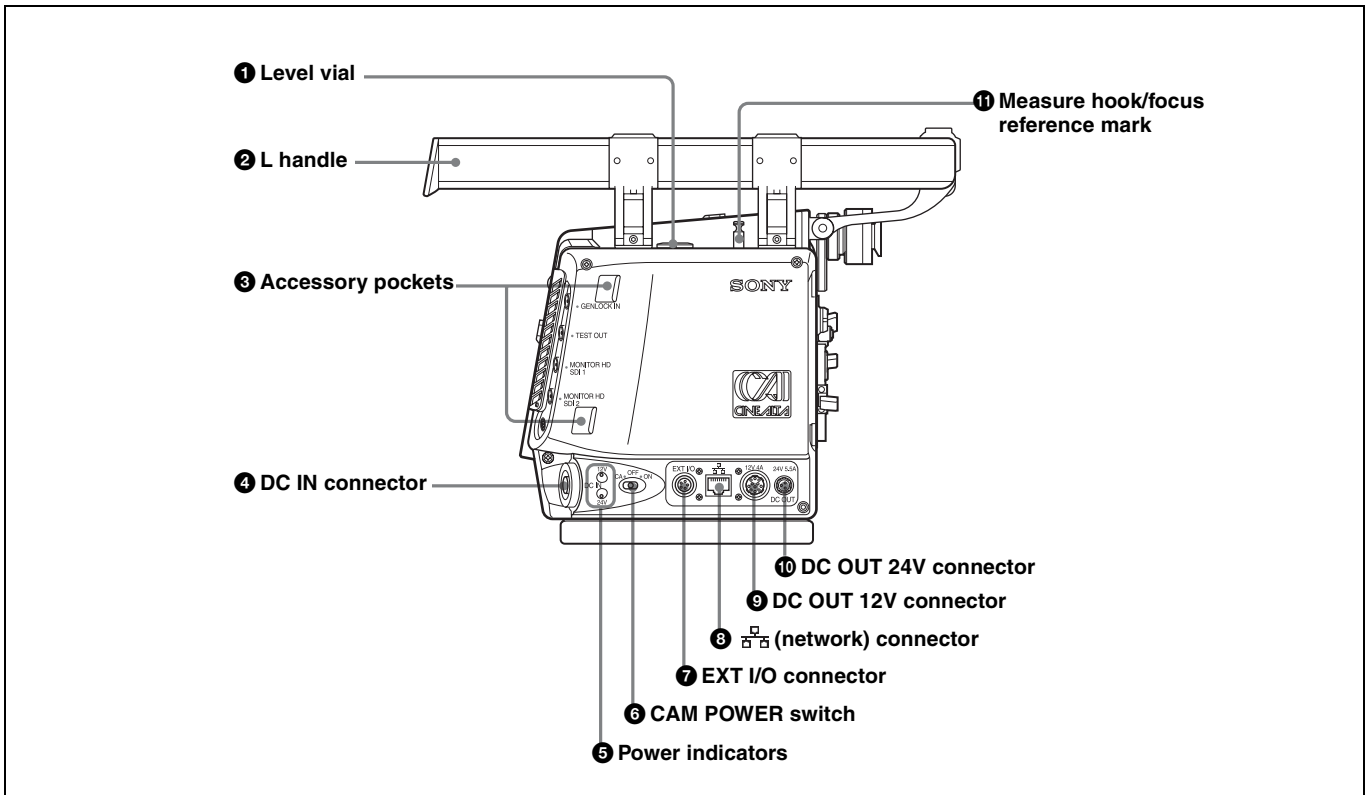

1 Level vial

Used as a reference to check that the camera stands horizontally. It can be fine-adjusted when required. If fine-adjustment is required, remove the cover and adjust it by rotating the three slotted-head screws.

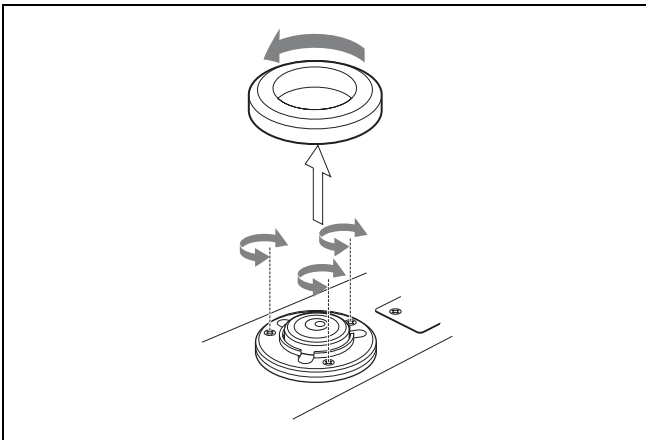

2 L handle

The L handle is attached to the top of the camera head at the factory. It has three screw holes ($\frac{3}{8}$ ") for accessories on the upper side. The assistant panel (*page 17*) can be mounted on the outside of the handle by attaching the supplied assistant panel hanger.

3 Accessory pockets

Using these accessory pockets in combination with the accessory receptacles (*page 12*) on the front panel, you can fix a certain accessory to the left side of the camera.

4 DC IN connector (LEMO 8-pin)

Power is supplied by using a specified power cord.

5 Power indicators

Either of the indicators lights according to the voltage of the power being supplied.

6 CAM POWER switch

CA: The camera is turned on using the power being supplied via the interface box (*page 17*) or CA-F101 (*page 22*) mounted on the rear.

Note that power is not supplied to an SRW-1 simultaneously mounted on the top via the interface box mounted on the rear. To supply power to the SRW-1, use power supply via the DC IN connector (LEMO 8-pin) of the camera head.

OFF: The power is cut off.

ON: The camera is turned on using the power being supplied from the DC IN connector (LEMO 8-pin) of the camera head.

Note

If you move the switch setting from ON to CA in one stroke, the power may not be cut off. To turn off the power, be sure to set the switch to the OFF position.

7 EXT I/O (external control) connector (5-pin)

For control via RS-232C.

8  (network) connector (RJ-45 type, 10BASE-T, 100BASE-TX)

For control from the MSU-900/950 Master Setup Unit, etc. via a network cable.

The necessary settings are made using the NETWORK menu displayed on the viewfinder or monitor screen.

CAUTION

For safety, do not connect the connector for peripheral device wiring that might have excessive voltage to this port. Follow the instructions for this port.

ATTENTION

Par mesure de sécurité, ne raccordez pas le connecteur pour le câblage de périphériques pouvant avoir une tension excessive à ce port. Suivez les instructions pour ce port.

ACHTUNG

Aus Sicherheitsgründen nicht mit einem Peripheriegerät-Anschluss verbinden, der zu starke Spannung für diese Buchse haben könnte. Folgen Sie den Anweisungen für diese Buchse.

9 DC OUT 12V (DC 12V power output) connector
DC 12V power can be fed to an accessory.

10 DC OUT 24V (DC 24V power output) connector
DC 24 V power can be fed to an accessory.

11 Measure hook/focus reference mark

Use as reference for focusing. The same reference mark is also provided at the right of the riser plate (*page 15*).

For actual measurement of the distance from a subject, you can fix the end of a tape measure to the hook.

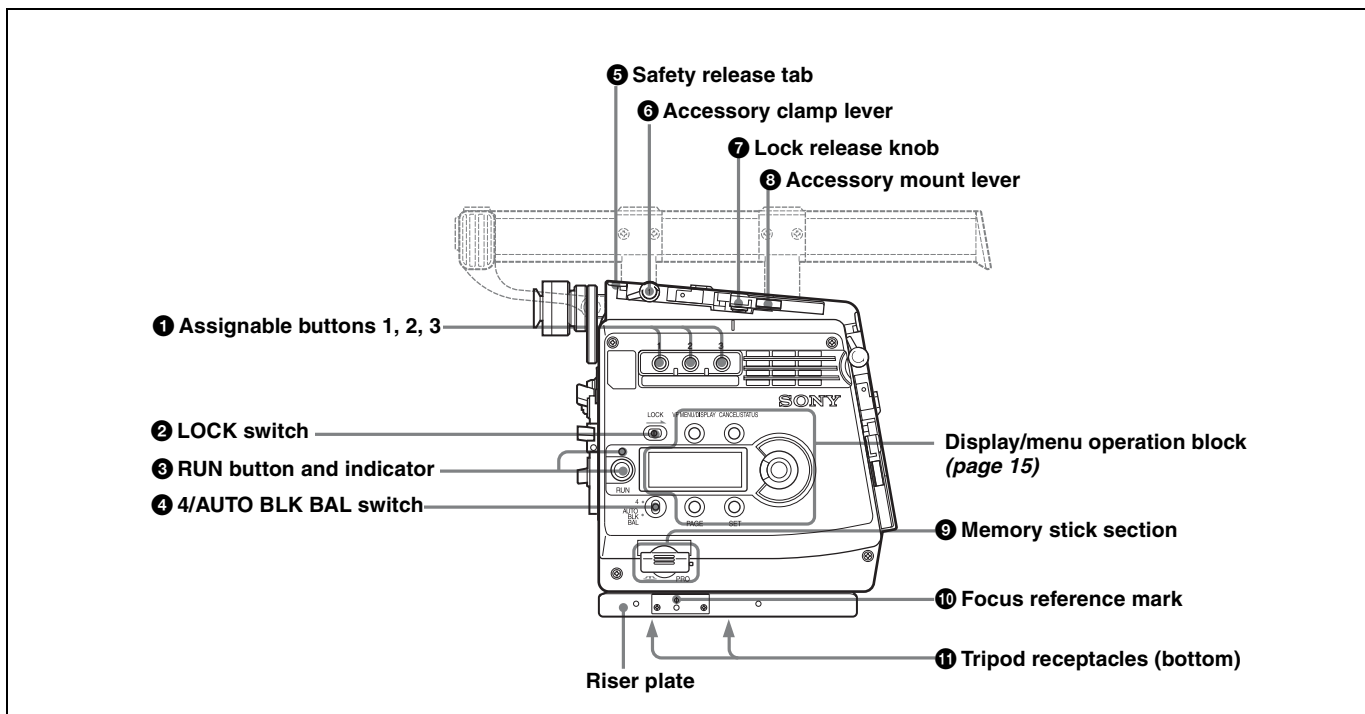
Right panel**1 Assignable buttons 1, 2, 3**

You can assign various functions to these buttons, using the subdisplay on the left panel or on the assistant panel or the menu displayed on the viewfinder or monitor screen. The ND filter selection function is assigned to button 1 and the CC filter selection function to button 2 at the factory. (No function is assigned to button 3.)

For details, see “3-2-11 Allocation of Functions to the Assignable Buttons and Switch” (*page 39*) and “3-7 Detailed Settings of the Switch Functions” (*page 53*).

2 LOCK switch

To disable operations on the panel.

You can make a setting to allow the RUN button to be activated even when the LOCK switch is set to ON on the <SUBDISPLAY 2> page on the USER (OPERATION) menu.

3 RUN button and indicator

To start/stop recording on the SRW-1 HD Portable Digital Recorder docked on the camera. The indicator is lit while the recorder is in Recording mode.

The indicator flashes as a warning in some cases.

For details on warning indication, see “Warning/Error Messages” (page 114).

The firmware of the SRW-1 may be required to be updated for use with this camera. For details, consult your local Sony representative.

4 Assignable 4/AUTO BLK BAL (auto black balance) switch

Push the switch downward to the AUTO BLK BAL side to start the auto black balance adjustment.

The function activated by pressing the switch upward to the 4 side can be selected using the subdisplay on the left panel or on the assistant panel or the menu displayed on the viewfinder or monitor screen.

For details, see “3-2-11 Allocation of Functions to the Assignable Buttons and Switch” (page 39) and “3-7 Detailed Settings of the Switch Functions” (page 53).

5 Safety release tab

6 Accessory clamp lever

7 Lock release knob

8 Accessory mount lever

For mounting/unmounting an SRW-1 HD Portable Digital Recorder or the supplied interface box to the top of the camera head.

The mounting/unmounting mechanism is the same as that on the rear panel (page 16).

For details, see “Chapter 2 Installation and Preparations”.

9 Memory Stick section

A slot to accommodate a “Memory Stick” is provided behind the rubber cap.

The access lamp is lit in red while writing or reading data to/from a “Memory Stick.”

You can use the “Memory Stick PRO” or “Memory Stick PRO Duo” with this camera. The “Memory Stick PRO Duo” media can be used without any adaptor.

Note

When the access lamp is lit in red, do not insert/remove the “Memory Stick” or turn off the camera.

For details, see “5-3-1 Using a “Memory Stick”” (page 96).

10 Focus reference mark

Used as a reference for focusing.

11 Tripod receptacles (bottom)

Two screw holes (for $\frac{3}{8}$ " camera screws) for tripod mounting are provided.

Display/menu operation block

Used to operate displays on the subdisplay and the viewfinder/monitor screen.

For details on menu operations, see “3-2-1 Basic Operation of the Subdisplay” (page 32) and “4-2 Basic Menu Operations” (page 61).

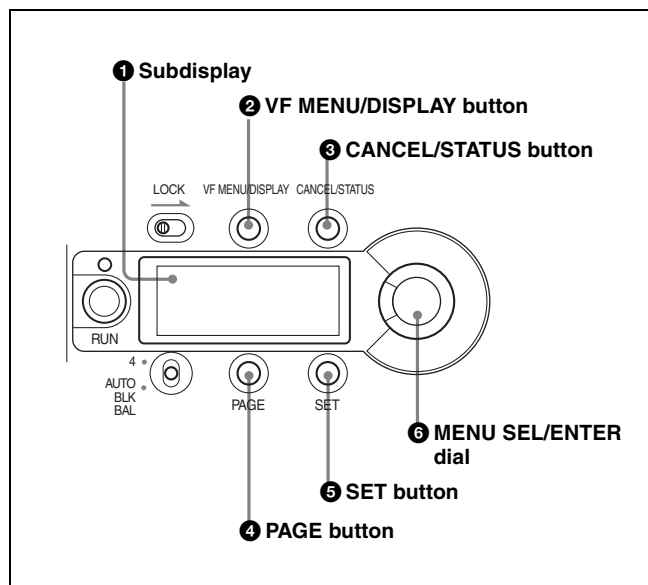

1 Subdisplay

For basic settings of this camera.

When an SRW-1 HD Portable Digital Recorder has been docked, some statuses of the recorder can also be displayed.

When the supplied assistant panel is connected, the same information will be displayed on the assistant panel.

2 VF (viewfinder) MENU/DISPLAY button

Press this button to select the display mode of the subdisplay and the viewfinder (monitor) screen.

3 CANCEL/STATUS button

In Menu Operation mode, press this button to cancel your entry or to resume the previous status.

If you press this button when the menu is not displayed on the viewfinder (monitor) screen, the status information of the camera will be displayed.

For the information displayed, see “3-6 Viewing and Setting the Viewfinder Displays” (page 47).

4 PAGE button

Press this button to flip the pages or register the setting on the subdisplay.

5 SET button

The subdisplay enters Data Change mode if you hold this button pressed for more than 1 second. Use this button also to flip to the previous page on the subdisplay.

6 MENU SEL (selection) /ENTER dial

Used to select or set the items on the subdisplay or the menu items on the viewfinder (monitor) screen.

Rear panel

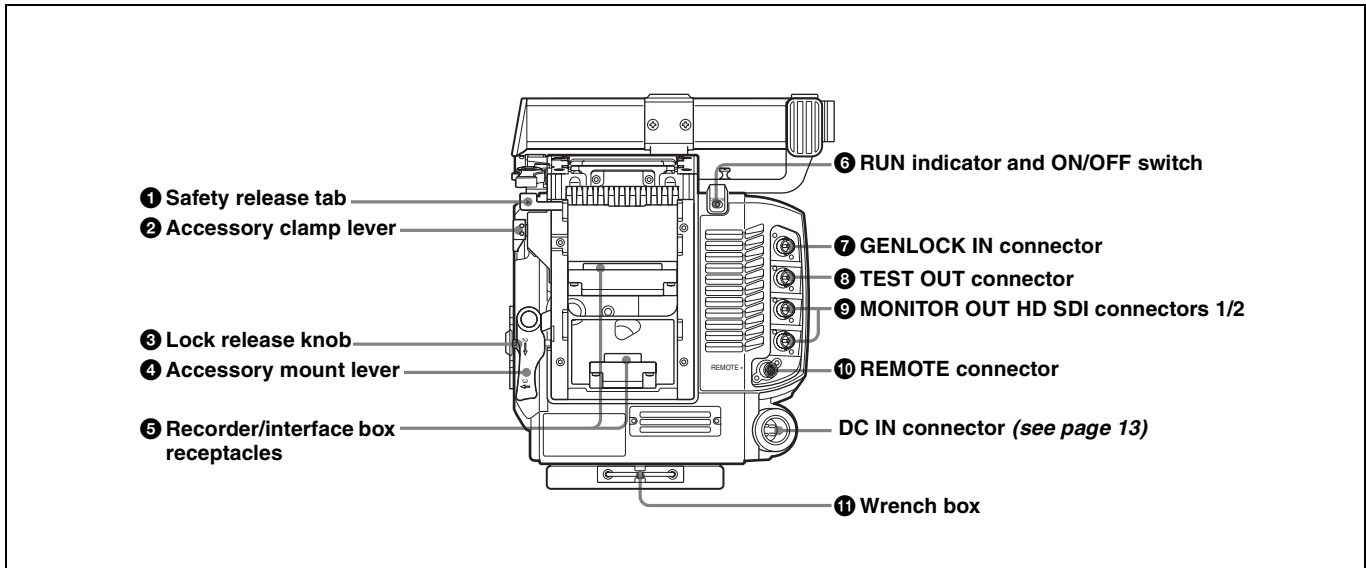

1 Safety release tab

2 Accessory clamp lever

3 Lock release knob

4 Accessory mount lever

For mounting/unmounting an SRW-1 HD Portable Digital Recorder or the interface box to/from the rear of the camera head.

The mounting/unmounting mechanism is the same as that on the top (page 15).

For details, see “Chapter 2 Installation and Preparations”.

5 Recorder/interface box receptacles

Signals and power are sent/received to/from an SRW-1 HD Portable Digital Recorder or the supplied interface box (page 17) mounted on the rear.

The same receptacles are provided on the top to send/receive signals and power to/from the recorder or the interface box mounted on the top.

When using a rechargeable battery

Use the receptacles on the rear panel. By attaching the BKP-L551 to the rear of the interface box, the camera can be operated on a battery. Note, however, that power will be fed only to the camera head and viewfinder. Provide another power source for the recorder.

6 RUN indicator and ON/OFF switch

When the switch is set to ON, the indicator will be lit while the recorder mounted on the camera is in Recording mode.

7 GENLOCK IN (external sync signal input) connector (BNC type)

Used for input of an external gen-lock signal (HD 3-level sync).

8 TEST OUT connector (BNC type)

An analog test signal is fed from the connector. The type of output signal can be set using a menu on the viewfinder or monitor screen.

9 MONITOR OUT HD SDI connectors 1/2 (BNC type)

An HD SDI signal for monitoring is fed from the connectors. The type of output signal can be set using a menu on the viewfinder or monitor screen. The same signal is output from connector 1 and 2. If you connect a recorder, such as an HDW-250/S280, to these connectors, recording synchronized with the SRW-1 becomes possible by enabling the function to output a REC trigger signal, using the menu.

10 REMOTE connector (8-pin)

Connect an external control device, such as the RM-B150/B750 Remote Control Unit.

11 Wrench box

A 3-mm wrench for attaching/detaching the handle and a 2.5-mm wrench for attaching/detaching the viewfinder shoe are accommodated.

1-3-2 Assistant Panel (Supplied)

The most parts are common to those on the right panel of the camera head. Connecting the panel to the CONTROL PANEL connector (page 12) of the camera head permits the camera and recorder to be operated at hand.

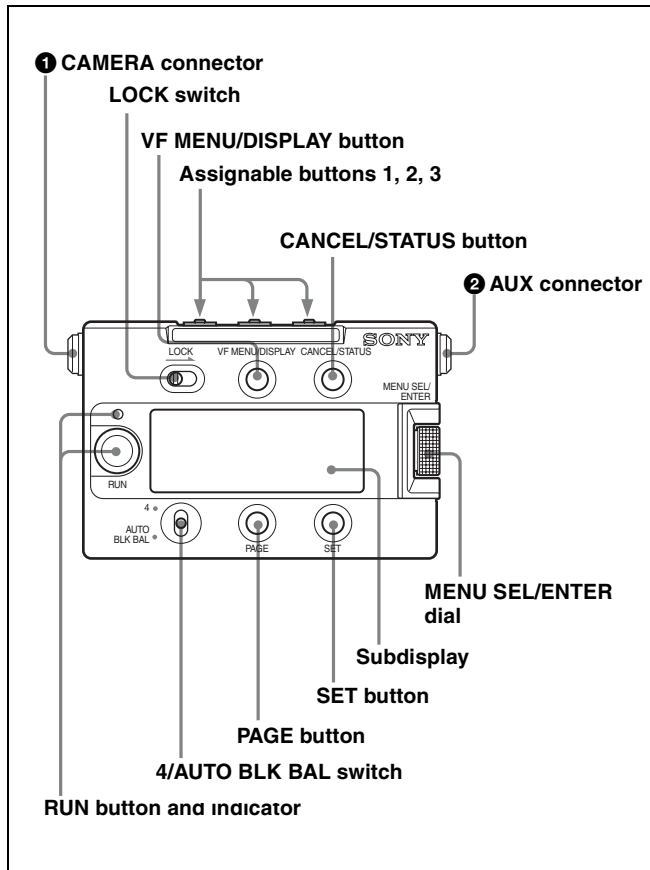

1 CAMERA connector

Using the supplied assistant panel cable, connect to the CONTROL PANEL connector of the camera head.

2 AUX (auxiliary) connector

Connect to an external device as required.

The other parts function the same as those on the right side panel of the camera head.

Note

If the assistant panel cable is disconnected/connected while you are operating the subdisplay or a menu on the viewfinder/monitor screen, the cursor/pointer on the subdisplay or on the menu page may inadvertently be moved. If a ? symbol is shown on the display, first register the setting, then disconnect/connect the cable.

1-3-3 Interface Box (Supplied)

Being attached to the top or the rear of the camera head, it transfers signals and power to/from the camera head.

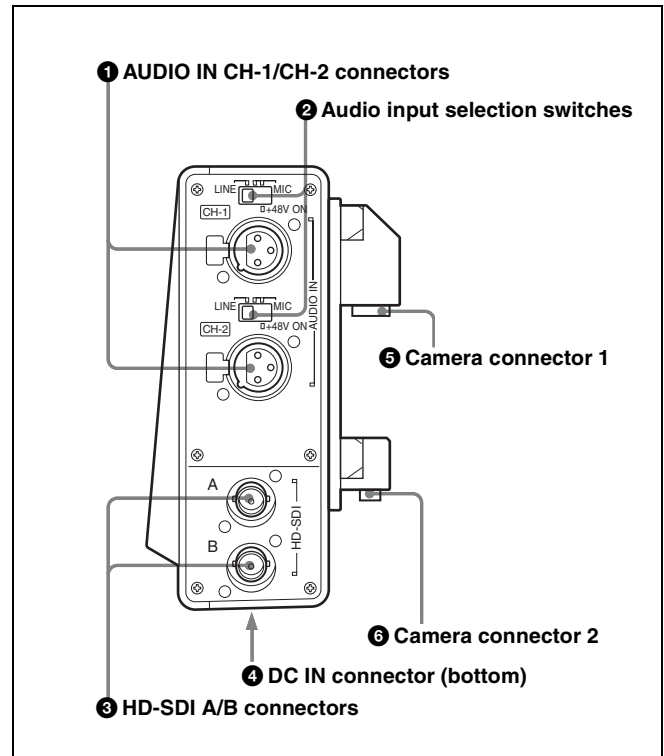

1 AUDIO IN CH-1/CH-2 connectors (XLR 3-pin, female)

Connect audio signals. Each connector is equipped with an input selection switch.

2 Audio input selection switches

Set to the appropriate position according to the equipment connected to the corresponding AUDIO IN connector.

LINE: When a line-level (+4 dBu) signal source is connected

MIC: When an external microphone is connected (No power is supplied.)

+48 V ON: To supply power of +48 V to the connected microphone

3 HD-SDI A/B connectors

For Dual Link outputs of an HD-SDI signal.

4 DC IN connector (XLR 4-pin)

Connecting the BKP-L551 Battery Adaptor or a specified power cable, supply power to the interface box. The power is also fed to the camera head, viewfinder, and lens.

Note

Power is not fed to an SRW-1 recorder.



5 Camera connector 1

When the interface box is mounted on the top or rear of the camera head, video/audio and control signals are sent/received to/from the camera head.

6 Camera connector 2

When the interface box is mounted on rear of the camera head, power is sent/received to/from the camera head.

2-1 Mounting the Interface Box

The supplied interface box can be attached to the top or rear of the camera head. Connection between the camera head and the interface box is achieved by mounting, eliminating additional cable connections.

- The same attaching/detaching system is used both on the top and the rear.
- The following instructions use the illustrations of attaching the interface box to the rear as examples.
- Although the illustrations show the statuses where the L handle has been detached, the interface box can be mounted/unmounted with the L handle attached.

To attach

- 1 Place the camera head on a stable, flat surface.
- 2 Rotate the accessory clamp lever upward (toward the lens when attaching to the top).

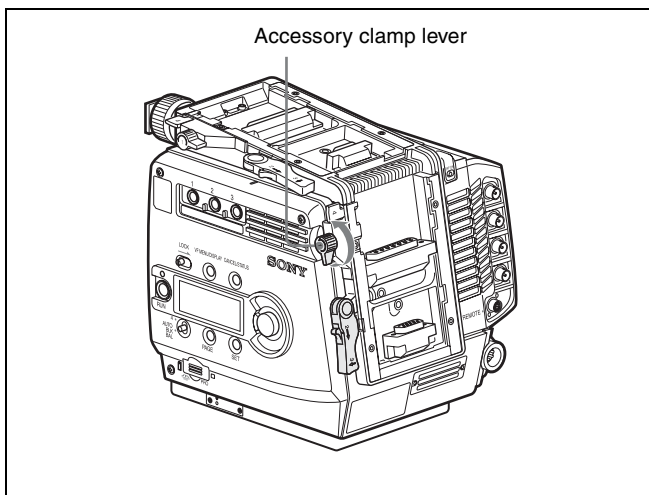

- 3 Release the lock by sliding the lock-release knob in the direction of the arrow (① in the figure below) then pull up the accessory mount lever (pull it toward the lens when mounting on the top) (② in the figure below).

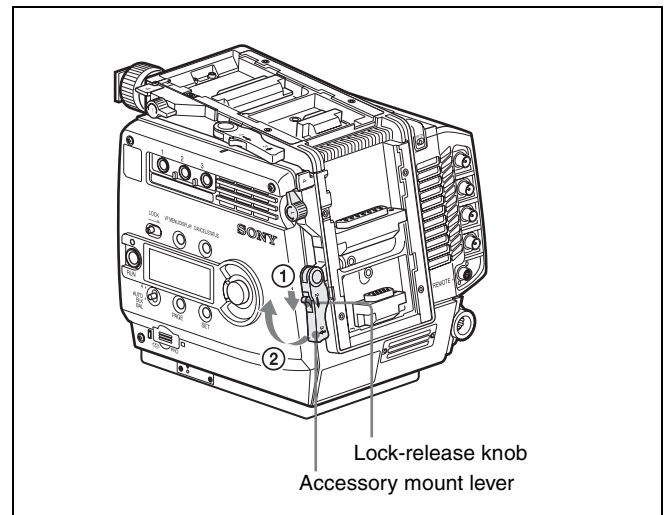

- 4 Aligning the matching line on the interface box with that on the camera head, fit the interface box into the camera head then push down on the box (slide it in the opposite direction of the lens when attaching to the top) so that the connectors engage.

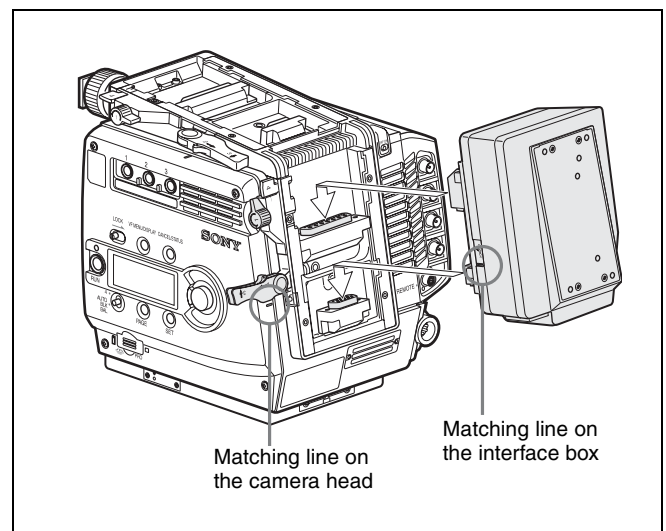

- 5** Rotate the accessory mount lever downward (pull it in the opposite direction of the lens when attaching to the top).

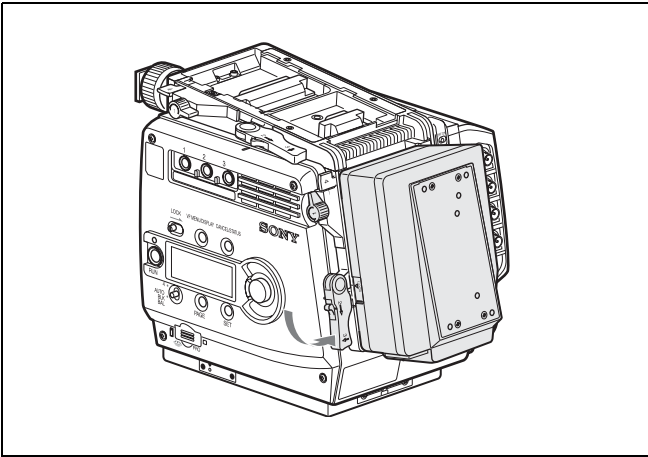

- 6** While holding the lock-release knob in the direction of the arrow, fold the accessory mount lever into its home position.

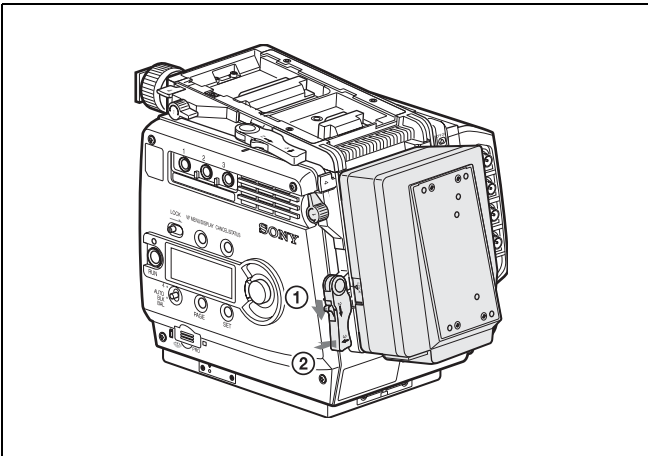

- 7** Rotate the accessory clamp lever downward (toward the opposite direction of the lens when attaching to the top).

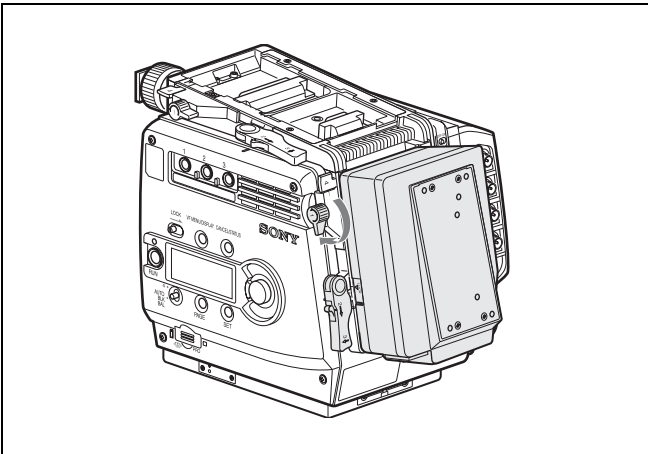

To detach

- 1** Rotate the accessory clamp lever upward (toward the lens when attaching to the top) (① in the figure below).
- 2** Release the lock by sliding the lock-release knob in the direction of the arrow (② in the figure below) then pull up on the accessory mount lever (③ in the figure below) (pull it toward the lens when mounting on the top).

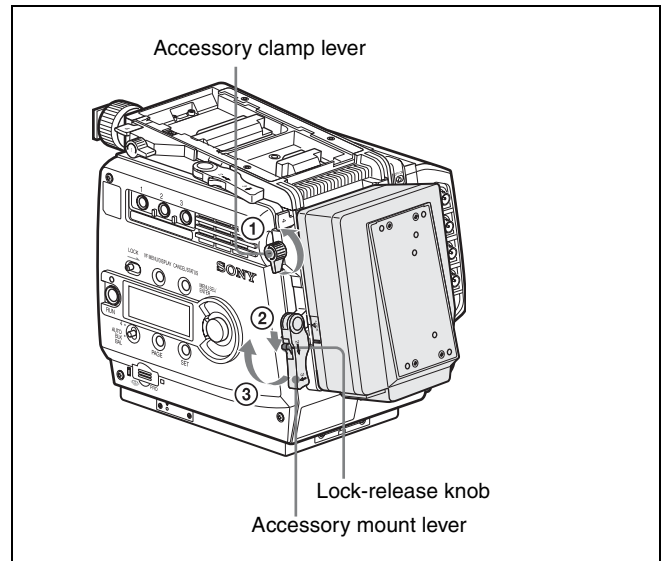

- 3** While holding the safety release tab pressed inward, pull up on the interface box to disengage the connectors, then pull out the box horizontally. (When attaching to the top, hold the safety release tab pressed downward, slide the interface box toward the lens to disengage the connectors, then pull out the box vertically).

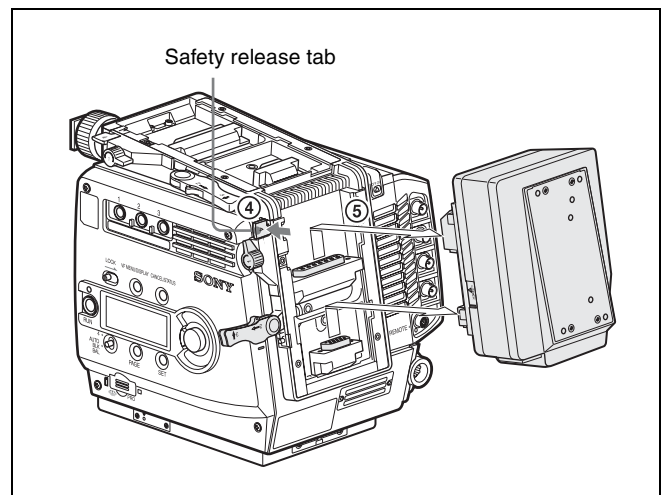

- 4** Return the accessory mount lever and accessory clamp lever to their home positions.

2-2 Mounting the SRW-1 Recorder

In the same manner as the interface box, the SRW-1 HD Portable Digital Recorder can be mounted on the top or rear of the camera head.

For handling of the SRW-1 Recorder, refer to the Operation Manual of the recorder.

Notes

- The firmware of the SRW-1 may be required to be updated for use with the camera.
For details, consult your Sony representative.
- When mounting the recorder, fix the camera head on a tripod in advance to keep the camera head stable.
For tripod mounting, see “2-6 Mounting the Camera to a Tripod” (page 25).
- When the camera is to be used with the recorder mounted, make sure that the camera is securely fixed and stable so that it will not topple over or fall.

Mounting to the top

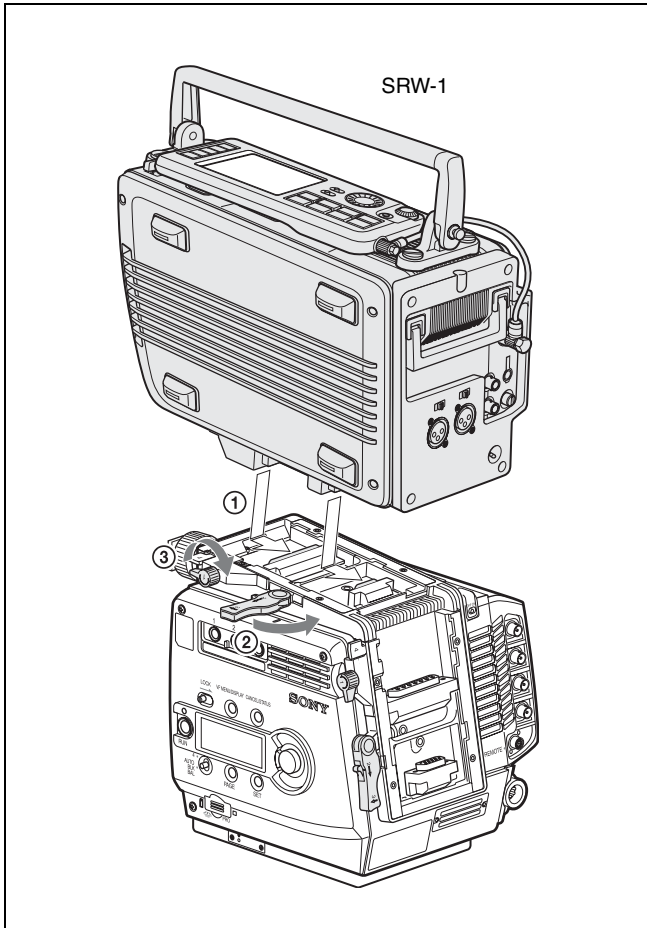

Mounting to the rear

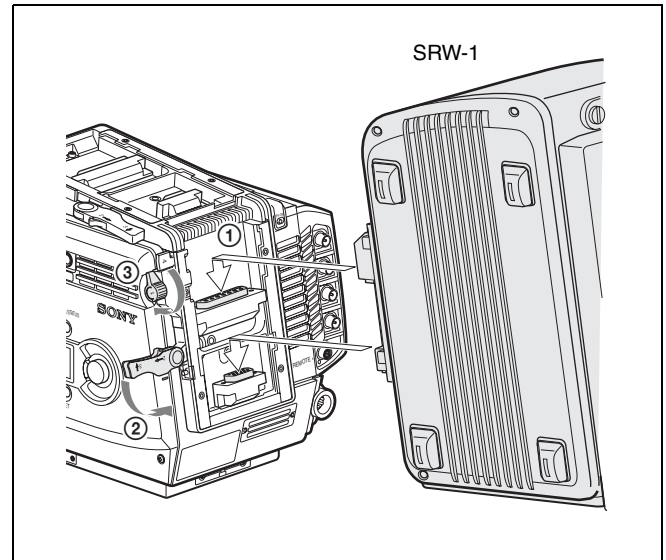

When connecting the SRW-1 recorder using cables

Attach the SRPC-1 HD Video Processor to the recorder to permit cable connection to the interface box mounted on the camera.

Use two coaxial cables for connections. The cable length can be extended up to 100 m when 5C-FB cables are used. The camera and recorder must be controlled independently when connected via cables.

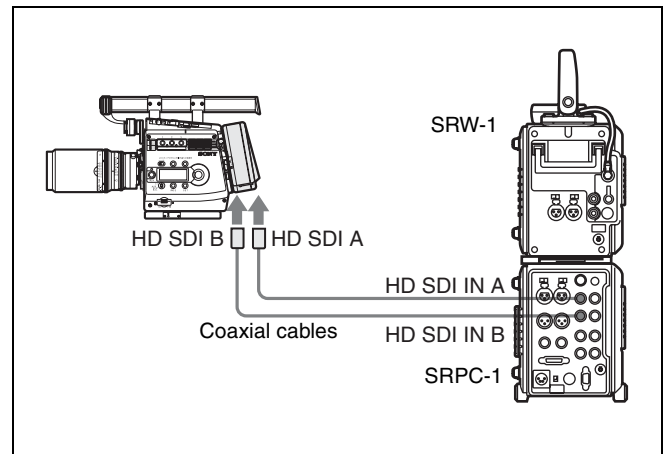

For optical connection, see the next section.

2-3 Mounting the CA-F101 and Optical Connection

For optical connection between this camera and an SRW-1, mount an HKSR-101 Optical Interface Unit on the SRPC-1 HD Video Processor and an optional CA-F101 Optical Fiber Camera Adapter to the camera.

Note

When using the CA-F101, confirm that the devices to be used in combination match the following requirements:

- The HKSR-101 Optical Interface Unit has been mounted on the SRPC-1 HD Video Processor.
- This camera is Ver. 1.3 or later.
- The SRW-1 and SRPC-1 are Ver. 2.6 or later.

For details, consult your Sony representative.

Mounting the CA-F101

The CA-F101 can be attached to the top or rear of the camera head in the same manner as the interface box.

For handling of the CA-F101, refer to the Operation Manual of the CA-F101.

Note

If the CA-F101 is attached to the top of the camera, the viewfinder can be placed to a higher position by attaching the viewfinder shoe supplied with the CA-F101 to the adapter.

In this case, remove the camera's viewfinder shoe to eliminate possible interference.

For details on viewfinder attachment, see "2-5 Attaching a Viewfinder" (page 24) and "Mounting-Attaching a Viewfinder to the Adapter" in the Operation Manual of the CA-F101.

For connection

Use an optional hybrid optical camera cable that conforms to ARIB (BTA S-1005B), ANSI/SMPTE (304M-1998/311M-1998), or EBU (R100-1999).

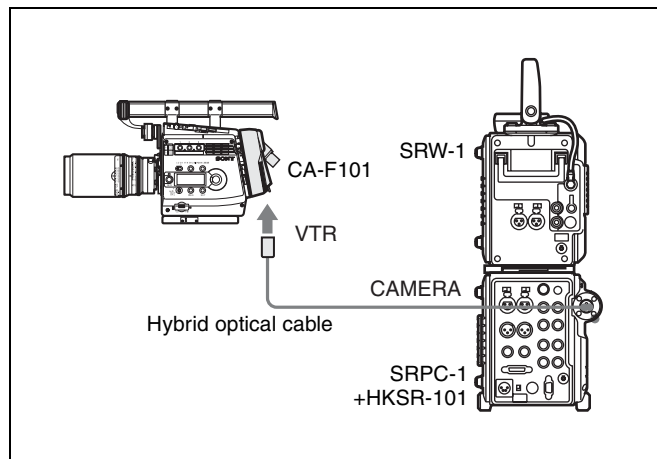

For details on the connection, refer to the Operation Manual of the CA-F101.

Note

When power is applied, the video format of the camera is automatically set to match that of the SRW-1. After that, the format setting made either from the camera or the SRW-1 becomes valid on both units.

2-4 Attaching a Lens

Attach an appropriate optional lens that conforms to the PL lens mount.

Note

Always use a lens whose projection from the flange (A in the figure) is less than 30 mm. Use of any lens that protrudes more than 30 mm will damage the internal filter.

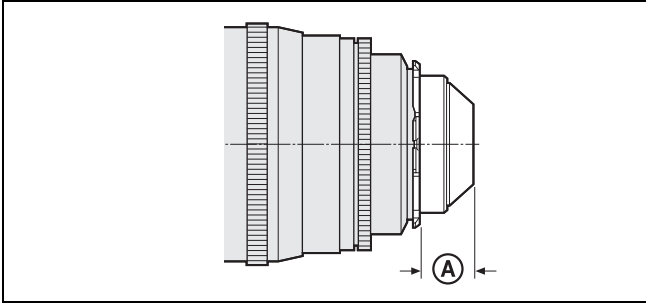

For information on handling lenses, refer to the lens' operation manual.

- 1 Rotate the lens fixing lever counterclockwise and remove the lens mount cap from the lens mount.

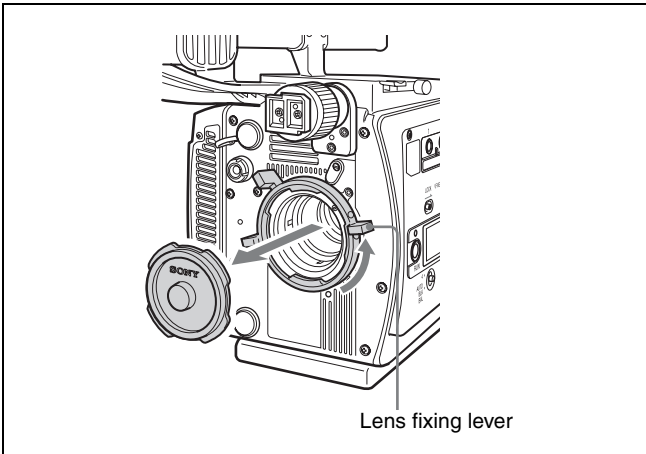

- 2 Align the lens' alignment pin with the notch in the upper part of the lens mount and insert the lens (sold separately) into the mount.
- 3 While supporting the lens, rotate the lens fixing lever clockwise to secure the lens.

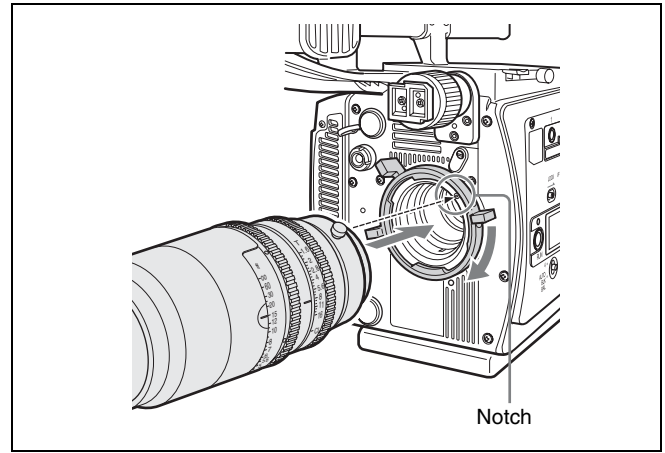

Selecting a lens file

With this camera, values, such as the compensation values, which are specific to the mounted lens can be registered in a lens file. You can perform necessary adjustments upon replacement of lenses by merely invoking the registered file.

Select the file using the subdisplay.

For lens file selection on the subdisplay, see "3-2-7 Selection of a Lens File" (page 37).

For details on the lens files, see "5-1 File Configuration" (page 93).

Adjusting the flange focal length

Adjustment of the flange focal length (distance between the lens mount attachment plane and the imaging plane) is necessary in the following situations:

- The first time a lens is attached
- When changing lenses
- If the focus is not sharp at both telephoto and wide angle when zooming

The flange focal length for this camera can be adjusted by rotating the adjustment screw on the front panel.

Use an Allen wrench (7/64" diagonal):

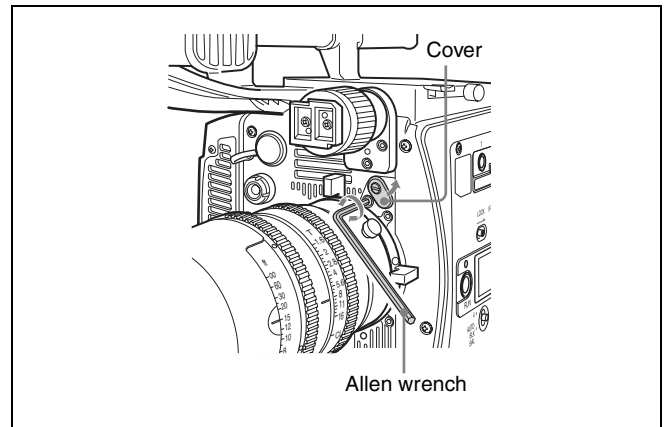

- 1 Loosen the fixing screw using a screwdriver, then open the cover.
- 2 Rotate the adjustment screw using an Allen wrench.

Clockwise rotation lengthens the flange focal length, and counterclockwise rotation shortens it.

Remember as a guide that ± 3 turns of the screw correspond to variation of the flange focal length of ± 0.15 mm.

When the adjustment is finished, close the cover and tighten the fixing screw.

2-5 Attaching a Viewfinder

Caution

When the viewfinder is attached, do not leave the camera with the eyepiece facing the sun. Direct sunlight can enter through the eyepiece, be focused in the viewfinder and cause fire.

For details on the viewfinder, refer to the instruction manual of the viewfinder.

If the viewfinder must be attached lower

Loosen the two screws, using the 2.5-mm wrench stored in the wrench box (page 16) to detach the viewfinder shoe, and attach it to the lower position using the lower screw holes.

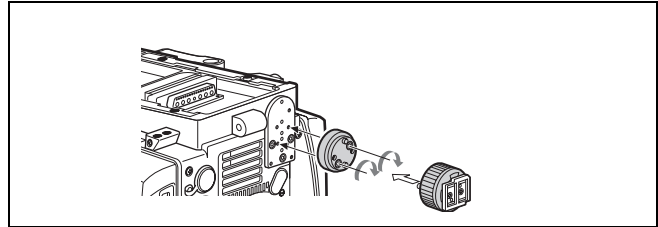

Attaching procedure

- 1 Fit the viewfinder to the viewfinder shoe and slide the viewfinder horizontally.

The viewfinder stopper automatically pops down.

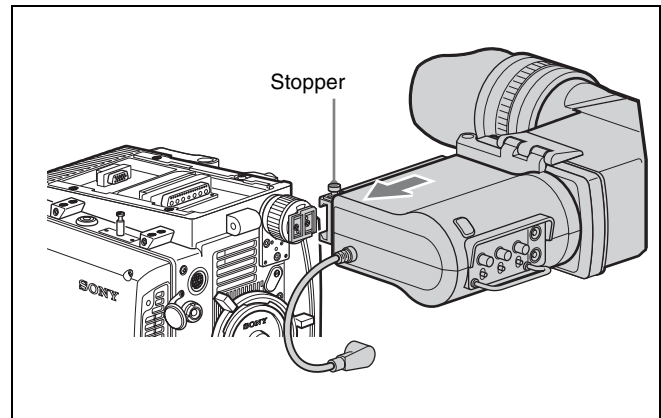

- 2 Set the viewfinder to the most convenient position, tighten the viewfinder positioning ring (① in the figure below), and connect the viewfinder cable to the VF1 connector of the camera (② in the figure below).

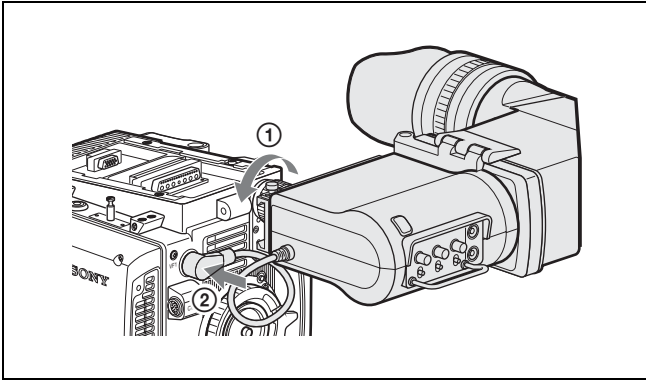

When the supplied center handle is attached to the top of the camera head, you can attach the viewfinder to the viewfinder shoe of the center handle. In this case, first remove the viewfinder shoe from the camera head.

For details on the center handle, see “2-7-2 Center Handle (Supplied)” (page 26).

Note

When the L handle is attached to the camera head, the attaching condition may be limited, owing to the viewfinder position and the rotating position of the hood.

When the second viewfinder is required

Connect it to the VF2 connector.

Using the menus, you can specify the display condition independently of the viewfinder connected to the VF1 connector.

Note

When two viewfinders are connected at the same time (via the VF1 and VF2 connectors), the HDVF-C950W cannot be used because of a limitation of current capacity.

To detach the viewfinder

Loosen the viewfinder positioning ring, pull on the viewfinder stopper, then pull out the viewfinder by sliding it in the direction opposite that when attaching.

2-6 Mounting the Camera to a Tripod

Two tripod receptacles (for $\frac{3}{8}$ " camera screws) are provided on the bottom of the camera head.

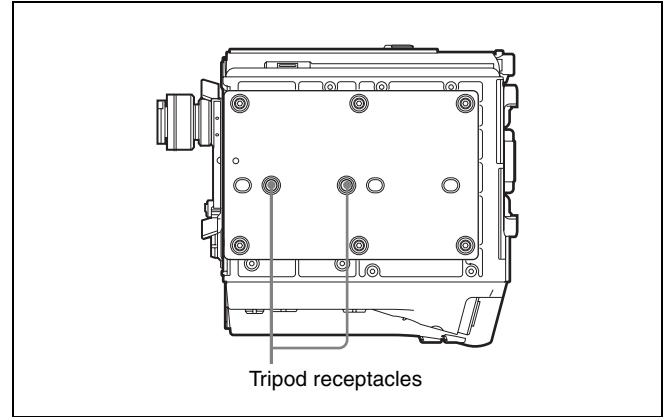

Notes

- Select an appropriate hole, considering the balance of the weight of the camera. If an inappropriate hole is selected, the camera may fall over.
- Check that the size of the selected hole matches that of the screw of the tripod. If they do not match, the camera cannot be attached to the tripod securely.

2-7 Attaching/Detaching Handles

2-7-1 L Handle

The L handle is attached to the top of the camera head at the factory. Three screw holes (for $\frac{3}{8}$ " camera screws for a tripod) on the upper side of the L handle can be used for fixing various accessories.

Mounting the assistant panel

By attaching the supplied assistant panel hanger, you can mount the assistant panel on the outside of the handle.

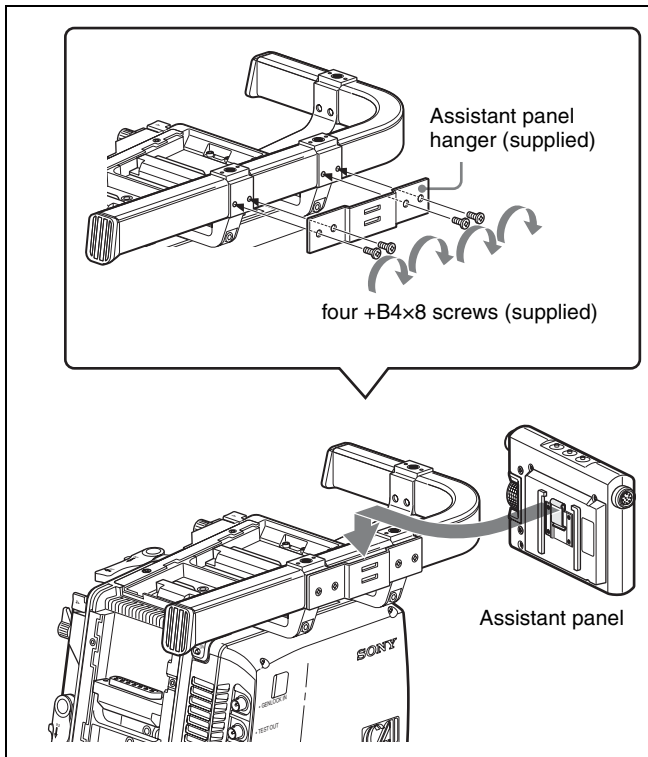

Detaching the L handle

If the L handle is not necessary or to be replaced with the supplied center handle, remove it by loosening the two screws, using the 3-mm wrench stored in the wrench box (page 16).

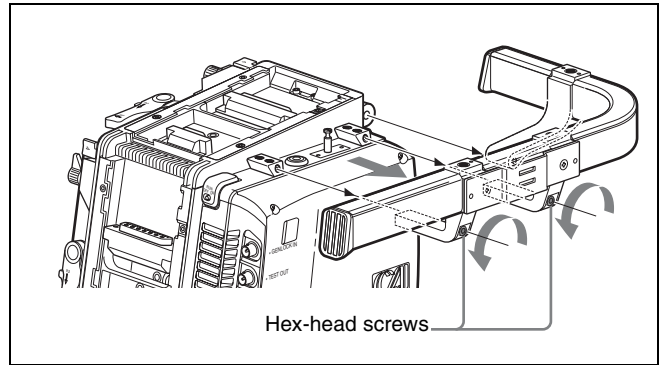

To attach the handle in the original position, reverse the procedure for detaching.

2-7-2 Center Handle (Supplied)

The supplied center handle can be attached to the top or rear of the camera head. Attach it so that the slanting side faces the back (or bottom). The screw holes on the upper side of the handle can be used for fixing various accessories.

Attaching the handle directly to the camera head

The handle can be attached/detached in the same manner as the interface box (see page 19).

Attaching the handle to the interface box mounted on the camera head

First remove the base plate from the handle by loosening the four screws, then attach it to the interface box.

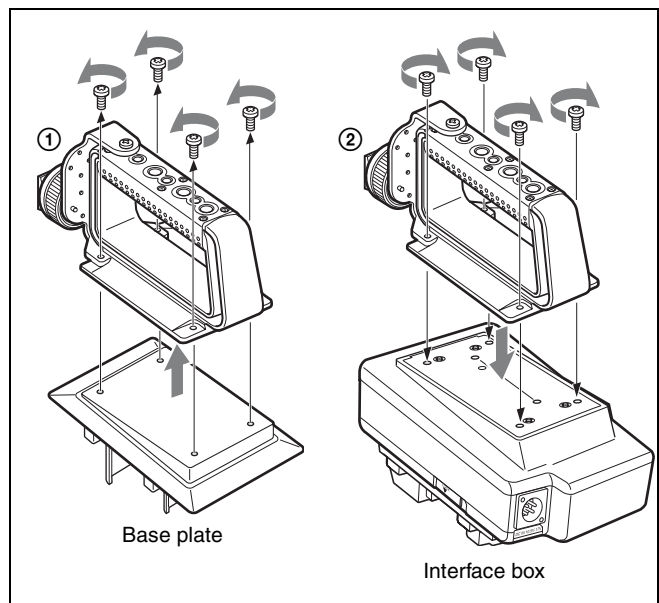

Attaching a viewfinder

When the supplied center handle is attached to the top of the camera head, you can attach the viewfinder to the viewfinder shoe of the center handle after removing the viewfinder shoe from the camera head.

The procedure for attaching the viewfinder is the same as when attaching it to the viewfinder shoe of the camera head (*see page 24*).

2-8 Preparing the Power Supply

This camera operates on DC 12 V (10.5 to 17 V).

Supplying power directly to the camera head

Connect a power supply to the DC IN connector (LEMO 8-pin) of the camera head.

Use a commercially available shielded cable by attaching the supplied 8-pin connector for a power cable.

For details on the connection, consult your local Sony representative.

To turn on the camera

Set the CAM POWER switch of the camera head to the ON side, and the camera is turned on.

Power is also supplied to viewfinders connected to the VF1 or VF2 connector of the camera head.

Power of 12 V or 24 V can be fed to accessories via the DC OUT connectors.

Supplying power via the interface box or CA-F101

To supply power via the interface box (supplied) or a CA-F101 Optical Fiber Camera Adapter (optional), mount the interface box or the CA-F101 to the rear of the camera head.

Connect a power supply to the DC IN connector (XLR 4-pin) of the interface box or the CA-F101.

Note

If the the interface box or the CA-F101 is mounted on top, power is not fed to the camera via the interface box or the CA-F101.

To turn on the camera

Set the CAM POWER switch of the camera head to the CA side, and the camera is turned on.

Power is also supplied to viewfinders connected to the VF1 or VF2 connector of the camera head.

To use an AC power source

An AC power source can be connected, by using the AC-DN2B AC Adaptor.

- 1 Attach the AC-DN2B to the interface box or the CA-F101.

- 2 Connect the DC power cord supplied with the AC-DN2B to the DC IN connector of the interface box or the CA-F101.
- 3 Connect the AC-DN2B to an AC power source.

To use a battery pack

The BP-GL95 Lithium-ion Battery Pack can be used. By attaching the BKP-L551 Battery Adaptor to the interface box or the CA-F101, connect the BP-GL95 Lithium-ion Battery Pack to the interface box or the CA-F101.

Notes

- Remove the battery pack if the camera will be out of use for an extended period.
- Charge the battery, using the specified battery charger, before use.

For charging, refer to the instructions for the battery charger.

- 1 Attach the BKP-L551 Battery Adaptor to the interface box or the CA-F101.

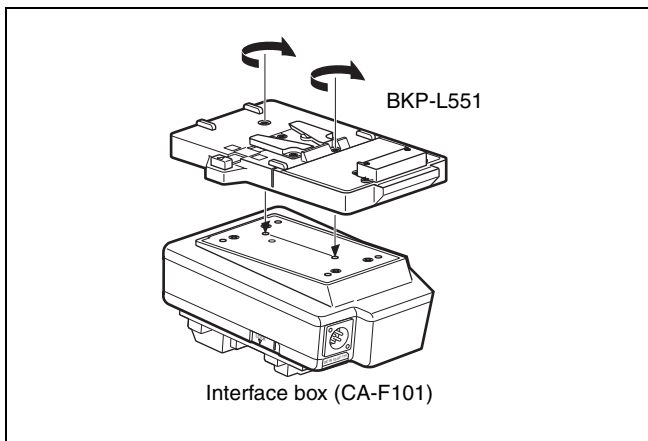

- 2 Aligning the groove on the BP-GL95 with the projection on the BKP-L551, slide the BP-GL95 so that the connectors engage.
- 3 Connect the DC cable of the BKP-L551 to the DC IN connector of the interface box or the CA-F101.

When the battery is connected to the DC IN connector of the interface box or the CA-F101, power is fed to the camera head and viewfinders connected to the VF1 and VF2 connectors of the camera head.

Note

Power is not supplied to the recorder mounted on the camera head. To supply power to the recorder, connect a power supply to the DC IN connector on the camera head.

2-9 Setting the Built-in Clock

When using the camera for the first time, set the built-in clock to the local time, using the <DATE> page of the MAINTENANCE menu displayed on the viewfinder screen.

To set the menu on monitor screen, connect a monitor to either of the MONITOR OUT HD SDI connectors.

Setting procedure

- 1 Turn on the camera.
- 2 While holding the MENU SEL/ENTER dial pressed, press the VF MENU/DISPLAY button.

The camera enters Menu Operation mode, and “TOP” is displayed at the upper-right corner of the screen.

- 3 Rotate the MENU SEL/ENTER dial to set the pointer to “TOP” and push on the MENU SEL/ENTER dial.

The TOP MENU screen is displayed.

```

<TOP MENU>
▶USER
  USER MENU CUSTOMIZE
  ALL
  •OPERATION
  •PAINT
  •MAINTENANCE
  •NETWORK
  •FILE
  •DIAGNOSIS
  
```

- 4 Rotate the MENU SEL/ENTER dial to position the pointer to MAINTENANCE and push on the MENU SEL/ENTER dial.

The CONTENTS page of the MAINTENANCE menu is displayed.

(The following display examples are those in Custom mode. They include some items not displayed in Cine mode.)

```

          CONTENTS      MOO
↓↓
▶01.<BASE SETTING>
  02.<AUTO SETUP>
  03.<WHITE SHADING>
  04.<BLACK SHADING>
  05.<OHB MATRIX>
  06.<AUDIO>
  07.<OUTPUT FORMAT>
  08.<DOWN CONVERTER>
  09.<POWER SAVE>
  10.<BATTERY ALARM SET>
  
```

- 5 Turn the MENU SEL/ENTER dial to scroll the page and position the pointer to <DATE>.

```

CONTENTS      M00
↓↓
02.<AUTO SETUP>
03.<WHITE SHADING>
04.<BLACK SHADING>
05.<OHB MATRIX>
06.<AUDIO>
07.<OUTPUT FORMAT>
08.<DOWN CONVERTER>
09.<POWER SAVE>
10.<BATTERY ALARM SET>
▶11.<DATE>

```

- 6** Push on the MENU SEL/ENTER dial.

The <DATE> page is displayed.

```

<DATE>      M12 TOP
DATE/TIME
  ↓
 2008/3/22   16:53

```

- 7** Turn the MENU SEL/ENTER dial and set the date and time.

Push on the MENU SEL/ENTER dial to shift to the next digit.

- 8** When the date/time setting is completed, press the VF MENU/DISPLAY button to exit Menu Operation mode.

For details on menu operations, see “4-2 Basic Menu Operations” (page 61).

3-1 Selection of the Basic Operation Modes

3-1-1 Overview of the Basic Operation Modes

With this camera, Cine mode and Custom mode can be switched. Cine mode is designed for shooting the materials that will undergo post-production editing and that do not need on-set grading, as with shooting with a film camera. Custom mode is designed for shooting with all the setting items of the camera set as you wish.

The items that can be set and the selectable values on the menus and from the remote control unit are different in Cine mode and Custom mode.

Cine mode (default mode)

- The subdisplay and the USER menu are mainly used.
- The items related to image creation are fixed at the factory-set values, and menu displays are simplified.
- Only auto black balance (ABB) can be activated as auto setup.

The white balance level is fixed at the preset value (3200K), and auto white balance (AWB) and WHITE R/G/B settings are not operative.

- On a remote control unit connected to the REMOTE connector of the camera, the values for the adjustment items whose settings fixed in Cine mode are not displayed. However, data for the ON/OFF setting items and selectable items are displayed although they are fixed in Cine mode.
- Reading/writing of files from/to a “Memory Stick” and data presetting are enabled only for the operator file that is included in the USER menu.
- Only retrieval by specifying a file number is allowed among the lens file operations.
- The reference file items are fixed to the default values set at the factory even if you have changed the values in Custom mode.

Custom mode

- This mode is designed for shooting with detailed settings on the menus or with operations from the remote control unit.
- The reference file, which stores the values to be used as reference for adjustments, and the scene files, which store the adjustment values specific to a particular scene, are available in this mode.
- User Gamma can be installed.
- Modification and storage of the lens files are possible.

Note

The settings for the file items adjusted in Custom mode are maintained when the camera is switched back to Cine mode. However, the video adjustment values that are temporarily changed and not stored in any file will be cleared upon mode switching.

For details on different items and values that can be set in each mode, see “4-3 Menu List” (page 64).

3-1-2 Switching of the Basic Operation Modes

At shipment, Cine mode is selected.

To switch to Custom mode

Referring to the procedures described in “2-9 Setting the Built-in Clock” (page 28), call up the <BASE SETTING> page of the MAINTENANCE menu on the viewfinder screen or the monitor screen and switch the modes.

On the same page, making settings for dynamic range and color space is also possible.

<BASE SETTING> page of the MAINTENANCE menu

```
<BASE SETTING>   MO1 TOP
SHOOT MODE : ►CUSTOM
D-RANGE    : EXTEND
COLOR SPACE: S-GAMUT
```

SHOOT MODE

Switch between CINE and CUSTOM on this line.

D-RANGE

With EXTEND, the dynamic range and sensitivity are improved. The S/N ratio is improved with NORMAL.

COLOR SPACE

Select color reproducibility:

S-GAMUT: This mode enables you to record with wider color space than with the conventional cameras (HDC-F950, HDW-F900R, etc.) whose color space is equivalent to that available with film cameras.

With postproduction processes, color expression can be substantially extended.

For details on reproducible gamuts, see “Color Space According to the COLOR SPACE Settings” (page 123).

Note

Images shot with the S-GAMUT setting will be seen in somewhat pale colors if they are reproduced on a conventional narrow color-space display, such as a CRT display.

F900: This mode enables you to shoot with color space equivalent to that available with conventional cameras. This facilitates color matching with conventional cameras. Furthermore, as wider color-space data available with this camera can be used without restriction, distinguishability of images with higher color saturation will be improved over that with conventional cameras.

F900R: This mode enables you to shoot with color space as close as possible to that of the HDW-F900R, by limiting the color space to that of the HDW-F900R. When using this camera in combination with the HDW-F900R, use this mode for easy color matching.

Note

This mode can be selected only when “COLOR F900R” is set to “ENABLE” on the <OTHERS 2> page of the MAINTENANCE menu.

DCDM REF PJ: This mode enables color reproducibility that is recommended by the Digital Cinema Initiatives (DCI). The camera can output signals for display devices that can reproduce this color space, such as a DLP projector.

If a video production is to be displayed on a device that complies with the DCI standards, shooting in this mode will minimize the necessity for postproduction processes, such as color correction.

For details on menu operations, see “4-2 Basic Menu Operations” (page 61).

3-2 Basic Settings with the Subdisplay

Basic settings of the camera can be easily performed, using the subdisplay located on the side of the camera or that of the assistant panel if connected via the CONTROL PANEL connector of the camera.

3-2-1 Basic Operation of the Subdisplay

For operation of the subdisplay, the buttons and dial shown in the figures below are used:

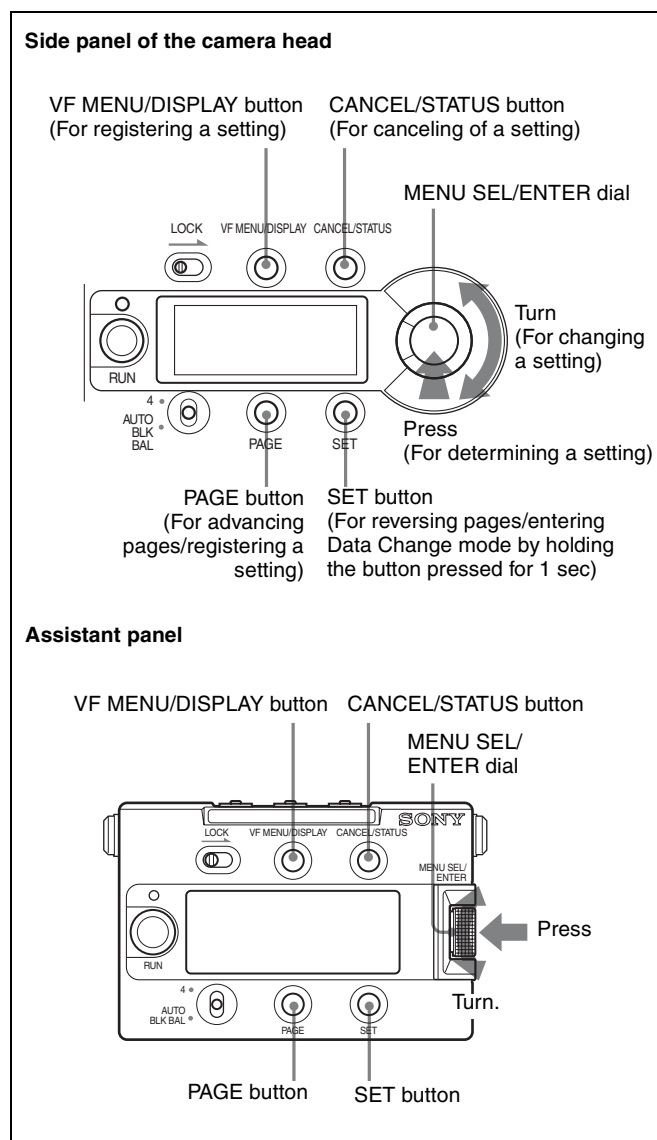

Operations of the subdisplay are possible with the buttons and dial both sides of the camera and assistant panel.

However, the LOCK switches disable the buttons and dial on their own sides. To inhibit operations on either side, set the LOCK switch on the side to be inhibited to ON.

Turning the MENU SEL/ENTER dial can change a setting, and pressing on it can register (ENTER) a setting.

To display the Setting pages

After the camera is turned on, the selected operation mode (CINE or CUSTOM) is displayed on the subdisplay for several seconds, after which the Setting page that was operated last time is displayed.

To advance to the next page

Press the PAGE button.

To go back to the previous page

Press the SET button (press and release the button within 1 second).

To change a setting

Press and hold the SET button for more than 1 second. Data Change mode is entered, the cursor (|) starts flashing, and the question mark (?) symbol appears at the rightmost position on the first line.

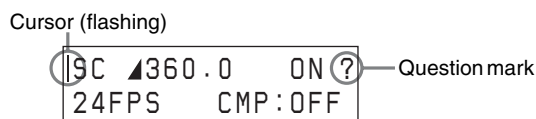

On a page with two or more setting items, each time the SET button is pressed, the cursor moves to the next item.



Move the cursor to the item you wish to modify then change the setting by turning the MENU SEL/ENTER dial.

Note

While the subdisplay is in Data Change mode, menu operations on the viewfinder cannot be performed.

To determine a changed setting

Perform one of the following:

- Press the PAGE button.
- Exit Data Change mode by pressing the MENU SEL/ENTER dial (the cursor and question mark disappear).
- Terminate the subdisplay operation by pressing the VF MENU/DISPLAY button.

To cancel a change on a setting

Without registering a change of a setting, press the CANCEL/STATUS button. The question mark disappears, and the original setting is restored.

To terminate subdisplay operation

Press the VF MENU/DISPLAY button.

3-2-2 Shutter Settings

The electronic shutter of this camera can be adjusted, with settings displayed in shutter angles, as with a film camera, in addition to exposure time.

Two operation methods are available for the adjustment: stepwise and continuous.

Step mode

Your frequently used shutter values (8 values at maximum) can be registered, enabling stepwise selection of the shutter values.

At shipment, the following values are registered:

STEP No.	Shutter angle
1	216.0°
2	180.0°
3	172.8°
4	150.0°
5	144.0°
6	90.0°
7	45.0°
8	22.5°

The corresponding shutter speeds vary according to the frame frequency and frame rate of the selected video format. The step shutter values can be changed and re-registered on the <SHUTTER ASSIGN> page of the USER (OPERATION) menu or the <SHUTTER/FPS> page of the USER (PAINT) menu.

Continuous mode (ECS)

The shutter values can be continuously changed in a range from 360.0 to 4.3 degrees.

To obtain your desired shutter value quickly, assign a value nearest your desired one in Step mode, switch to Continuous mode, then adjust the shutter value.

Note

In a case where a remote control unit connected to the REMOTE connector of the camera is used, adjustment in Step mode is enabled with SHUTTER and adjustment in Continuous mode is enabled with ECS (there is no need to set to ECS ON). However, to display the shutter values on

the remote control unit correctly, upgrading of the version is required.

For details, consult your local Sony representative.

Shutter setting page

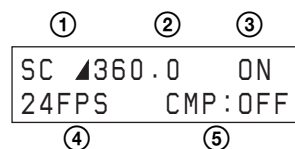

To select a shutter value step by step

In Step mode, one of the registered shutter values (8 values at maximum) can be selected, as follows:

- 1 Move the cursor to the left of “S” at ①.
(Immediately after the shutter setting page is switched to Setting Change mode, the cursor is always displayed at the left of “S”.)
- 2 Display the shutter angle you wish to use at ② by turning the MENU SEL/ENTER dial.

The eight registered values for shutter angle will be displayed one after another as the MENU SEL/ENTER dial is turned.

To select an arbitrary shutter value

To use a shutter value that is not registered as a step shutter value, use Continuous mode.

- 1 Press the SET button to move the cursor to the left of “C” at ①.
- 2 Display the shutter angle you wish to use at ② by turning the MENU SEL/ENTER dial.

The shutter value changes continuously as the MENU SEL/ENTER dial is turned.

To change the units

You can change the displayed units for the shutter values from shutter angle (deg) to speed (sec).

- 1 Move the cursor to the left of ▲ at ②.
- 2 Turn the MENU SEL/ENTER dial.

The display at ② changes to the corresponding speed value.

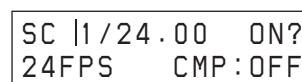

The speed value for the shutter angle varies depending on the selected video format and frame rate.

To select the frame rate (number of frames per second)

When a video format of “Select FPS” is selected, the frame rate (number of frames per second) can be selected.

- 1 Move the cursor to ④.
- 2 Display the frame rate (number of frames per second) you wish to use by turning the MENU SEL/ENTER dial.

If a format other than those of “Select FPS” is selected, the frame rate cannot be changed.

To use Compensation mode

This camera enables you to compensate for changes in the video level when the FPS value is changed.

Two compensation modes are provided: one that depends on shutter angles and another that depends on electric gain.

- 1 Move the cursor to ⑤.
- 2 Select the compensation mode you wish to use by turning the MENU SEL/ENTER dial.

AC: Angle Compensation mode

When you change the frame rate, the shutter angle is automatically corrected, retaining the video level.

GC: Gain Compensation mode

When you change the frame rate, the electric gain is automatically corrected, retaining the video level. The current shutter angle setting is maintained.

For details on switching of the compensation modes with the menu, see “3-9 Detailed Shutter Settings” (page 54).

When shutter is not used

Select OFF at ③.

The shutter value indication at ② becomes “----”.

To change the registered values for the step shutter

Call up the <SHUTTER ASSIGN> page of the USER (OPERATION) menu on the viewfinder.

For details on how to operate the menu, see “4-2 Basic Menu Operations” (page 61).

<SHUTTER ASSIGN> page

<SHUTTER ASSIGN>		10 TOP
STEP	[deg]	[sec]
1:	216.0	(1/39.97)
2:	180.0	(1/48.00)
3:	172.8	(1/50.05)
4:	150.0	(1/57.63)
5:	144.0	(1/60.07)
6:	90.0	(1/95.92)
7:	45.0	(1/192.2)
8:	22.5	(1/383.0)
ADD:	▶---.-	DEL PRESET

STEP 1-8

In the [deg] column on each line, the registered shutter angle is indicated. In the [sec] column, the shutter speed value converted according to the currently selected frame rate is displayed.

ADD

For newly registering a step shutter value.

Display a shutter angle you wish to register then push on the MENU SEL/ENTER dial. The selectable angle values are from 360.0 to 4.3 degrees. The Step shutter values are automatically sorted in descending order.

If eight values have been already registered, the message “STEPS FULL” is displayed, and a new value will not be added. In such a case, delete an unneeded value beforehand, using DEL.

DEL

For deleting registered step shutter values.

When the pointer is positioned at DEL, an asterisk (*) is displayed at the left of STEP 1.

Move the asterisk to the left of the value you wish to delete then push on the MENU SEL/ENTER dial. That value is deleted, and the items after the deleted one will be automatically renumbered.

Example: When deleting 90.0

3:	172.8	(1/50.05)
4:	150.0	(1/57.63)
5:	144.0	(1/60.07)
*6:	90.0	(1/95.92)
7:	45.0	(1/192.2)
8:	22.5	(1/383.0)
ADD:	---.-	▶DEL PRESET



3:	172.8	(1/50.05)
4:	150.0	(1/57.63)
5:	144.0	(1/60.07)
6:	45.0	(1/192.2)
7:	22.5	(1/383.0)
8:	---.-	(-/---.-)
ADD:	---.-	▶DEL PRESET

As the numbers for which no value is registered are skipped during a selection operation, deleting step shutter values with lower frequency of use will improve the operation speed.

At maximum, numbers 2 to 8 can be left unregistered.

PRESET

For resetting all step shutter values to default.

Addition and deletion of step shutter values can be performed on the <SHUTTER/FPS> page of the USER (PAINT) menu.

For information on the <SHUTTER/FPS> page, see “3-9 Detailed Shutter Settings” (page 54).

3-2-3 RAMP Operation

The RAMP function permits you to change the FPS value in a specified duration during shooting.

The RAMP operation page of the subdisplay or the PAINT menu can be used for the RAMP operation.

While the RAMP operation page is displayed on the subdisplay, assignable buttons 2 and 3 function as RAMP operation buttons regardless of the allocations of functions (see page 39).

RAMP operation page

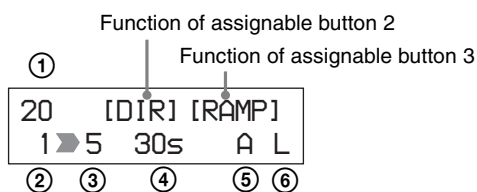

At ① on the first line, the current FPS value is displayed.

1 Set the starting FPS value at ②.

2 Set the ending FPS value at ③.

Pressing assignable button 2 reverses the value at ② (starting FPS) and that at ③ (ending FPS).

3 Set the transition time (duration) in the range from 0 to 30 seconds at ④.

4 Select the shutter compensation mode (page 34) at ⑤.

A: Angle Compensation mode
G: Gain Compensation mode
-: No compensation

5 Select the RAMP mode (FPS transition curve) at ⑥.

L: Linear mode
E: Exponential mode

Assignable button 3 will not function with the – (RAMP OFF) setting.

6 Press assignable button 3 to start the RAMP operation.

The FPS transition is executed in the duration you specified in step 3.

The FPS value at ① changes according to the transition progress, and an asterisk appears at the right.

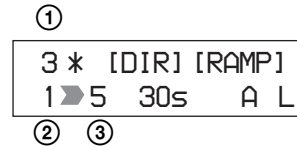

When the RAMP operation is completed, the asterisk disappears and the starting FPS value ② and ending FPS value ③ will be reversed.

Notes

- You cannot change the ② to ⑥ settings after starting the RAMP operation.
- During a RAMP operation, any FPS control is disabled on the camera, from the SRW-1, and remote control units.
- The page on the subdisplay cannot be changed during a RAMP operation.

RAMP operation using the menu

You can also set and execute the RAMP function on the <RAMP> page of the PAINT menu (see page 76).

When you start a RAMP operation from the menu, the RAMP operation page is automatically displayed on the subdisplay.

3-2-4 Selection of Video Formats

On the subdisplay, the video format can be selected from among the eight registered formats.

At shipment, the following four formats are registered, and numbers 5 to 8 are not used:

No.	Registered format	Indication on the subdisplay
1 (default)	23.98P 4:4:4	_23.98P 444
2	S23.98P 4:4:4	S23.98P 444
3	S59.94P 4:2:2	S59.94P 422
4	23.98P 4:2:2	_23.98P 422

Video-format selection page

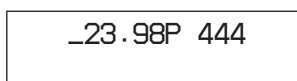

On the first line, the currently selected format is displayed.

Data-set mode enables you to select the desired format from among the registered formats.

```

_23.98P 444 ?
1:_23.98P 444 M

```

Turn the MENU SEL/ENTER dial until the desired format is displayed on the second line. The unused numbers are skipped.

You can select unregistered video formats from among available ones, using the <OUTPUT FORMAT> page of the MAINTENANCE menu.

For details on how to select a video format, see “3-13 Detailed Setting of the Video Format” (page 59).

Changing the registered formats

The registered formats (eight at maximum) can be changed with the following procedure:

- 1 Display the number of the registered format you wish to change on the second line.
- 2 Move the cursor to the left of “M” and turn the MENU SEL/ENTER dial.
The selectable formats are displayed in sequence as you turn the dial.
- 3 When the format you wish to register is displayed, press the MENU SEL/ENTER dial.

The registration is updated, and the camera starts to operate with the selected format.

To change the registered formats using the menu

The registered formats can also be changed on the <SUBDISPLAY 1> page of the USER (OPERATION) menu.

For details on how to operate the menu, see “4-2 Basic Menu Operations” (page 61).

<SUBDISPLAY 1> page

```

<SUBDISPLAY 1>      11
FORMAT MEMORY
1: ▶_23.98P 444
2: S29.97P 444
3: S59.94P 422
4: _23.98P 422
5: NO ASSIGN
6: NO ASSIGN
7: NO ASSIGN
8: NO ASSIGN

```

Position the pointer on the line you wish to change and push on the MENU SEL/ENTER dial. The <FORMAT MEMORY> subpage for format selection will be displayed.

<FORMAT MEMORY> page

```

<FORMAT MEMORY>      ESC
↓
▶00:NO ASSIGN
01:_23.98P 444
02:S23.98P 444
03:_29.97P 444
04:S29.97P 444
05:S59.94P 444
06:_23.98P 422
07:S23.98P 422
08:_29.97P 422
09:S29.97P 422

```

Position the pointer to the format you wish to select and push on the MENU SEL/ENTER dial. The registered format will be changed.

If NO ASSIGN is selected, selection with that number becomes invalid.

3-2-5 Retrieving the ND Offset

If an ND filter is attached to the matte box, etc., the white balance may be in variance. In such a case, you can retrieve an appropriate ND offset value from a previous adjustment you made. Use the ND filter selection page on the subdisplay.

The offset values ND: 2 to 5 are stored with respect to the white balance stored for ND: 1 as the reference.

For the ND offset adjustment, see “5-3-7 Storage of the OHB File” (page 100).

ND filter selection page

```

ND: 1

```

3-2-6 Selection of the Gain, Color Temperature, and White Balance Memory

The setting items and values in Cine mode and Custom mode are different.

In Cine mode: Selecting the gain and color temperature

Gain setting page

```

①      ②
0dB(450) 800%
TUNGSTEN

```

At ① on the first line, the gain value is selected from among the following: -6 dB, -3 dB, 0 dB, 3 dB, 6 dB, 9 dB, and 12 dB. The corresponding ISO sensitivity is displayed in parentheses. For ② on the first line, you can select either dynamic range or latitude for the indication (see “Indications of the ISO sensitivity and dynamic range” mentioned later).

On the second line, the color temperature is selected from TUNGSTEN or DAYLIGHT.

With DAYLIGHT, electrical gain of 5600K is ON.

At shipment, the gain is set to 0 dB, and the color temperature is set to TUNGSTEN.

The white balance adjustment value is fixed at the preset value (3200K).

In Custom mode: Selecting the gain, color temperature, and white balance memory

Gain setting page

0dB (450)	800%
5600K-ON	W:P
③	④

The first line is in common with Cine mode.

At ③ on the second line, electrical gain of 5600K can be switched ON or OFF.

At ④ on the second line, the white balance adjustment value can be selected.

Setting	Adjustment value
W:P	Preset value (3200K)
W:A	The value stored in memory A
W:B	The value stored in memory B

At shipment, the gain is set to 0 dB, color temperature is set to 5600K-OFF, and the white balance memory is set to W:P.

For details on white balance adjustment, see “3-4 White Balance Adjustment (in Custom mode)” (page 42).

Indications of the ISO sensitivity and dynamic range

The ISO sensitivity value displayed on the Gain setting page is defined as “the value with which the video input becomes 20% when shooting a gray-scale chart of 18% reflection rate.”

Note that the video output value with respect to this input will vary depending on the selected gamma.

Either dynamic range or latitude can be selected for the indication.

The value displayed with % as a dynamic range shows the limit on the high-luminance side in percentage (100%=

input level) in a case where the white of the gray scale provides 100% (700 mV) output with the ITU-R709 gamma (standard gamma).

The value displayed with **E** as a latitude shows the latitude on the high-luminance side by an f-stop value, using a gray-scale chart of 18% reflection rate as the key light. The latitude at the low-luminance side can be reproduced up to approx. -6.5 stop at 0 dB.

Note

As the dynamic range indication shows a value for the input video, the dynamic range of the output video is limited by the output settings as follows:

• If a gamma other than S-LOG is selected

The upper limit is clipped according to the output video limitation specified by the gamma setting.

When you select a curve as Hyper Gamma No. 4, which compresses 460% input to 109%, the output video is fed within the range up to 460% of input video even if 800% is displayed on the subdisplay as the dynamic range as the output video is limited to 109%.

Using CvpFileEditor V4.0, you can change the dynamic range of Hyper Gamma and create a user gamma curve having no dynamic range limitation.

• If the white clip function is in use

As the white clip function limits the level of output video, the dynamic range specified for the input video may not be obtained for video output.

• If “Select FPS” is ON and Compensation is in Gain mode

The value of the dynamic range may decrease by up to half at maximum, depending on the FPS settings.

Memo

Why the ISO sensitivity is defined for 20% input

Defining the level of gray scale of 18% reflection rate for the ISO sensitivity on the linear curve (defining with input signal) permits you to use the values as the absolute reference for proper gamma conversion in postproduction. In addition, defining the output for 20% input with ITU-R709 so that it becomes the reference code for Cineon curve allows high compatibility.

3-2-7 Selection of a Lens File

With this camera, the compensation data for the mounted lens can be adjusted in Custom mode and registered in the built-in memory in lens files (max. 32 files).

You can invoke the compensation data for the mounted lens by merely selecting the corresponding file.

Lens file selection page

```
LENS: 1
No Offset
```

On the first line, select the number of the lens file.
On the second line, the lens-file name corresponding to the selected file is displayed.

The selected lens file will be retained until a new lens file is selected. As long as the same lens is used, further selection of the lens file is not required.

Note

All the lens files are named “No Offset,” with all zero settings at shipment. File registration and modification of data in a lens file must be performed in Custom mode.

For details on the lens files, see “Chapter 5 Storage and Retrieval of User Setting Data”.

3-2-8 Confirmation of the Time Code and Tape Remaining

When the SRW-1 HD Portable Digital Recorder is attached to this camera, the time code of the recorder and approximate tape remaining (unit: minutes) can be confirmed on the subdisplay.

Time code/tape remaining display page

```
TCR 00:00:00:00
20min
```

The time code is displayed on the first line, and the approximate tape remaining is displayed on the second line, in the range of 1 to 99 min.

Time code that is displayed on the first line

Indication	Meaning
TCR 00:00:00:00	Time code data of the LTC reader
TCR 00:00:00:00	Time code data of the LTC reader (DF)
TCR.00:00:00:00	Time code data of the VITC reader
UBR 00 00 00 00	User bit data of the LTC reader
UBR.00 00 00 00	User bit data of the VITC reader
TCG 00:00:00:00	Time code data of the time code generator
TCG 00:00:00:00	Time code data of the time code generator (DF)
UBG 00 00 00 00	User bit data of the time code generator
CTL -0:00:00:00	Data of the CTL counter

Indication	Meaning
T*R 00:00:00:00	Time code cannot be read with the LTC reader.
U*R 00 00 00 00	User bit cannot be read with the LTC reader.
T*R.00:00:00:00	Time code cannot be read with the VITC reader.
U*R.00 00 00 00	User bit cannot be read with the VITC reader.

The type of the displayed time code data is linked with the SRW-1. Select the type of the displayed time code data on the SRW-1.

3-2-9 Confirmation of the Power Voltage and Selection of Fan Operation Mode

The values in voltage of the power sources connected to the camera can be confirmed on the subdisplay.
On the same page, the operation mode of the built-in fans can also be selected.

Voltage confirmation/Fan Operation mode select page

```
① 11.4V ② 24.1V
FAN:AUTO1
```

At ① and ② on the first line, the values in voltage of the 12-V and 24-V power systems are displayed, respectively. If power is not supplied, “- -” is displayed. If the voltage falls to the NEAR END level, the indication starts flashing. If the voltage falls further down to the END level, the indication flashes rapidly.

The NEAR END and END levels can be set on the <BATT ALARM SET> page of the MAINTENANCE menu.

Selecting Fan Operation mode

On the second line, the operation mode of the built-in fans can be changed according to the ambient temperature or the operation mode of the recorder.

Setting	Operation of the fans
AUTO1 (default)	The fans are automatically controlled according to the internal temperature. During recording, the fans are controlled for a quiet condition. Normally use this mode.
AUTO2	The fans are normally controlled as those in MIN mode and for a quieter condition during recording. Note that recording time must be limited to a short duration. Use this mode only under ordinary ambient temperature.
MIN	The quietest fan operation is maintained without synchronization with recording. This is the best mode if recording must be made for more than 30 minutes in a quiet condition such as a concert hall. Use this mode only under ordinary ambient temperature.
MAX	The fans rotate at the maximum speed to lower the internal temperature.

Notes

- If the internal temperature rises so high that the TEMPERATURE CARE message is displayed, the fan rotation speed will automatically increase to lower the temperature.
- If the internal temperature rises so high that the TEMPERATURE WARNING message is displayed, the Fan Operation mode setting is automatically changed to MAX. After the temperature is sufficiently lowered and the message disappears, manually restore the original mode.

To change Fan Operation mode using the menu

You can also change Fan Operation mode (FAN MODE) by using the <OTHERS 1> page on the USER (MAINTENANCE) menu (*page 82*).

3-2-10 ON/OFF of the Character Indication

Superimposition of character data onto camera images can be activated or deactivated by output destination.

Character indication setting page

VF1 : ON	VF2 : ON
MON : ON	VBS : ON

VF1

Viewfinder connected via the VF1 connector (default: ON)

VF2

Viewfinder connected via the VF2 connector (default: ON)

MON

Monitors connected via the MONITOR OUT HD SDI connectors (default: ON)

VBS

Monitors connected via the TEST OUT and REMOTE connectors (default: ON)

3-2-11 Allocation of Functions to the Assignable Buttons and Switch

Various functions can be allocated to assignable buttons 1 to 3 and assignable switch 4 (the upper position of the 4/AUTO BLK BAL switch) that are located on the side of the camera and on the assistant panel.

At shipment, no function is allocated to these buttons.

Functions that can be allocated to assignable buttons 1 to 3

Menu indication	Function
ND	Selection of the ND filter
REC REVIEW	With REC REVIEW set to NORM on the SRW-1, the last part of the recorded tape is normally rewound for 3 seconds (maximum: 10 seconds) then played back. With REC REVIEW set to ALL on the SRW-1, the tape is rewound to the recording start position then played back.
PB(VF)	The video signals being played back on the SRW-1 are output to the viewfinder.
VF709GAM	ON/OFF of the fixed ITU-R709 gamma of the viewfinder
MONI709GAM	ON/OFF of the fixed ITU-R709 gamma of the monitor
FAN MODE	Switching of Fan Operation mode
GAIN -9/-18 dB	If the picture becomes too bright when you set the lens iris to its open end to assist the focus adjustment, the electric gain can be temporarily decreased to resume the proper picture level by using this function. Each push on the assignable button changes the setting in the sequence of OFF, -9 dB, -18 dB, OFF, and so on. Notes <ul style="list-style-type: none"> • The gain-decreased condition is automatically released in approx. 1 minute. • Do not perform recording in the condition where the gain is decreased with this function.
OFF	None

Functions that can be allocated to assignable switch 4

Menu indication	Function
AWB	Automatic white balance adjustment
BARS	Color-bar indication
TEST1	Test signal output
OFF	None

Note

Even if AWB is allocated to assignable switch 4, AWB does not function in Cine mode.

Assignable buttons 1/2 setting page

AS1 : OFF
AS2 : OFF

The functions of buttons 1 and 2 can be assigned on the first and second line, respectively.

Assignable button 3/switch 4 setting page

AS3 : OFF
AS4 : OFF

The functions of button 3 and switch 4 can be assigned on the first and second line, respectively.

3-2-12 Brightness Adjustment of the Subdisplay

The brightness of the subdisplay can be adjusted, in eight levels.

Subdisplay brightness adjustment page

BRIGHT : 1

The higher the value, the brighter the display.

3-2-13 Selection of Gamma Tables

The gamma curves can be selected on the gamma table selection page of the subdisplay.

Gamma table selection page

GAMMA : STANDARD
5 ITU-R709

Select the gamma table on the first line (STANDARD, HYPER, SPECIAL, or USER) and the gamma curve on the second line.

For details on the available gamma curves, see “3-11 Selecting the Gamma” on page 56.

3-2-14 Selection of Color Spaces

Color reproducibility can be selected on the color space selection page of the subdisplay.

Color space selection page

COLOR SPACE
F900

Select the color space mode (S-GAMUT, F900, F900R, or DCDM REF PJ) on the second line.

For information on color space modes, see “3-1-2 Switching of the Basic Operation Modes” (page 30) and “Color Space According to the COLOR SPACE Settings” (page 123).

3-2-15 Checking the Optical Levels

When the SRW-1 is connected via the optional CA-F101 Optical Fiber Camera Adapter, you can check the optical levels on the optical status page.

Optical status page

CAM : ■■■■■■◀
VTR : ■■■■■■◀

CAM: Optical reception level on the camera side
VTR: Optical reception level on the SRW-1 side

The status of the level is indicated with eight segments.

- If 6 to 8 segments are lit: Normal
- If 3 to 5 segments are lit: Cautioning level
- If only 1 or 2 segments are lit: Warning level
- If no segment is lit: No signal or unusable level

For details, refer to the Operation Manual of the CA-F101.

3-2-16 Limiting Pages that are Displayed on the Subdisplay

You can limit pages that are displayed on the subdisplay. Use Setup mode of the subdisplay or the OPERATION menu.

To set the subdisplay to Setup mode

Hold the PAGE button pressed for more than 5 seconds to set the subdisplay to Setup page.

Subdisplay in Setup mode

```
SHUTTER
ON
```

Select the page to be switch ON/OFF on the first line and select ON or OFF on the second line. Any page with an OFF setting will not be displayed on the subdisplay.

Menu indication	Target page
SHUTTER	Shutter setting page
RAMP	RAMP operation page
FORMAT	Video-format selection page
ND	Optical filter selection page
GAIN/WHT/5600K	Gain setting page
LENS FILE	Lens file selection page
TC/TAPE REM	Time code/tape remaining display page
VOLT/FAN	Voltage confirmation/Fan Operation mode select page
CHAR MIX	Character indication setting page
ASSIGN SW1/ SW2	Assignable buttons 1/2 setting page
ASSIGN SW3/ SW4	Assignable button 3/switch 4 setting page
BRIGHT	Subdisplay brightness adjustment page
GAMMA TABLE	Gamma table selection page
COLOR SPACE	Color space selection page
OPITICAL LEVEL	Optical status page

To switch subdisplay pages ON/OFF using the menu

You can also switch subdisplay pages ON/OFF using the <PAGE SELECT> subpage that can be accessed from the <SUBDISPLAY 2> page of the USER (OPERATION) menu.

For details on how to operate the menu, see “4-2 Basic Menu Operations” (page 61).

<SUBDISPLAY 2> page

```
<SUBDISPLAY 2>      12
LOCK SW MODE
CAMERA  : -RUN
PANEL   : FULL
▶PAGE SELECT
```

Move the pointer to PAGE SELECT then push on the MENU SEL/ENTER dial to jump to the <PAGE SELECT> subpage, where limitation of display pages can be assigned.

<PAGE SELECT> page

```
<PAGE SELECT>      ESC
↓↓
SHUTTER              :▶ON
RAMP                 : ON
FORMAT               : ON
ND                   : ON
GAIN/WHITE/5600K    : ON
LENS FILE            : ON
TIME CODE/TAPE REM  : ON
VOLTAGE/FAN MODE    : ON
CHARACTER MIX       : ON
ASSIGNABLE SW1/SW2  : ON
```

To switch ON/OFF, move the pointer to an item whose setting you wish to change and push on the MENU SEL/ENTER dial.

3-3 Black Balance Adjustment

In order to maintain high picture quality when using the camera, it is necessary to set the black balance appropriately. After turning on the camera, apply power to the camera for several minutes, then be sure to perform the black balance adjustment before starting any picture adjustment.

Automatic black balance adjustment

Push the assignable switch 4/AUTO BLK BAL switch on the side of the camera or on the assistant panel down to the position AUTO BLK BAL then release it. Automatic black balance adjustment is performed.

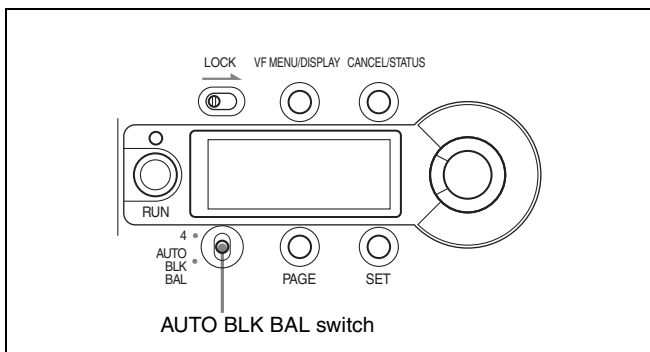

During adjustment, “ABB: EXECUTING” is displayed on the viewfinder screen. When the adjustment process is completed successfully, the message “ABB: OK” is displayed.

Notes

- During black balance adjustment, ND is automatically set to 5 (CAP), and the iris is closed.
- During black balance adjustment, the gain switching circuit will work automatically, and the viewfinder screen will flicker several times. This is not a malfunction.

When automatic black balance adjustment fails

If the automatic black balance adjustment process does not end successfully, the error message “ABB: NG” will be displayed on the viewfinder screen for approximately three seconds.

If this error message is displayed, try black balance adjustment again.

If the error message continues to be displayed after several attempts, the camera requires internal inspection.

3-4 White Balance Adjustment (in Custom mode)

When the camera is used in Custom mode, if the lighting conditions change, readjust the white balance.

When adjusting the white balance, select the white balance memory. The adjustment value is fixed to 3200K when the preset memory is selected.

The selected memory can be confirmed with the status display on the viewfinder screen (page 47).

The memory selection can be made on the subdisplay or from a connected RM-B750 Remote Control Unit.

Automatic white balance adjustment

- 1 Select the memory A or B, using the subdisplay or the remote control unit (default: preset memory).

For details on how to select on the subdisplay, see “3-2-6 Selection of the Gain, Color Temperature, and White Balance Memory” (page 36).

- 2 Select the appropriate filter according to the lighting conditions, using the subdisplay or the assignable buttons.

See “3-2-5 Retrieving the ND Offset” (page 36).

- 3 Place a white pattern in the same lighting conditions as the subject and zoom in on it so that a white area is obtained in the screen.

A white object (white cloth, a white wall, etc.) near the subject may be used in place of a white pattern.

The minimum white area required for adjustment is as illustrated below:

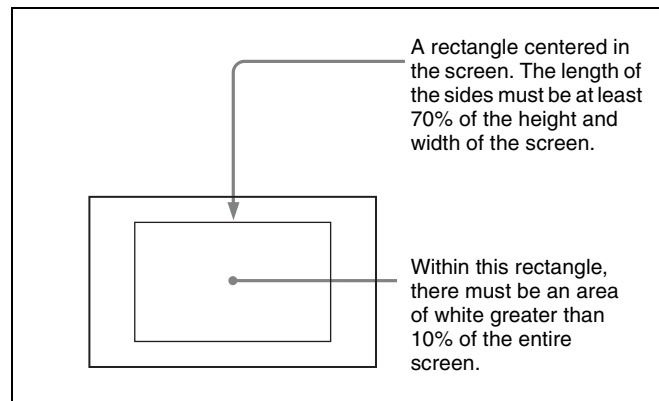

Note

Be careful not to have any spots of high illumination in the rectangle.

4 Adjust the lens iris opening or set the shutter to ON.

With a manually adjusted lens: Set the opening to an appropriate value.

With a lens that has automatic iris control: Set the lens' automatic/manual iris control switch to automatic.

Or, set the video level to an appropriate value, using the shutter setting.

5 Perform automatic white balance adjustment.

To perform adjustment on the <AUTO SETUP> page of the MAINTENANCE menu

Referring to the procedure mentioned in “2-9 Setting the Built-in Clock” (page 28), select MAINTENANCE menu on the TOP MENU screen and call up the <AUTO SETUP> page.

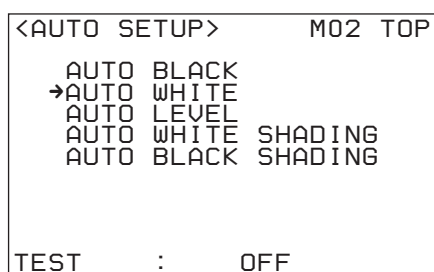

Position the pointer to AUTO WHITE then push on the MENU SEL/ENTER dial.
Select “EXEC” when a confirmation message is displayed.

For details on the menu operations, see “4-2 Basic Menu Operations” (page 61).

To perform adjustment with the assignable switch

If AWB is allocated to assignable switch 4, push the switch up toward “4” then release it.

For the procedure for assigning a function to the switch, see “3-2-11 Allocation of Functions to the Assignable Buttons and Switch” (page 39) or “3-7 Detailed Settings of the Switch Functions” (page 53).

To perform adjustment from the remote control unit

When the RM-B750 or RM-B150 remote control unit that is connected to the REMOTE connector is used, press the AWB button.

During adjustment

The message “AWB EXECUTING” is displayed on the viewfinder screen. When the adjustment process is completed successfully, the message “AWB: OK” is displayed.

When automatic white balance adjustment fails

If the automatic white balance adjustment process does not end successfully, the error message “AWB: NG” will be displayed on the viewfinder screen for approximately three seconds.

If this error message is displayed, try white balance adjustment again.

If the subject has a higher color temperature, use an optical filter or set 5600K to ON, then try white balance adjustment again.

If the error message continues to be displayed after several attempts, the camera requires internal inspection.

Note

If the automatic white balance adjustment is performed on a system where the Select FPS function (see page 59) is available, set a value that is greater than half the maximum FPS value as the FPS value. If you do not, the error message “AWB: LOW FPS” will be displayed, and automatic white balance adjustment will not be available.

Example: With S23.98PsF, as the maximum FPS value is 24 FPS, set it to 13 FPS or greater before the automatic white balance adjustment is to be performed. Although the maximum FPS value is 50 FPS with S59.94PsF, set it to 31 FPS or greater.

3-5 Setting the Camera Outputs

3-5-1 Selecting a Video Output Signal for Each Connector

The type of video signals to be output to the MONITOR OUT HD SDI 1/2, TEST OUT, and REMOTE connectors can be selected.

For selection, use the <MONITOR OUTPUT> page of the USER (OPERATION) menu that is displayed on the viewfinder screen.

<MONITOR OUTPUT> page

```
<MONITOR OUTPUT> 07
COLOR          : ▶COLOR
OUTPUT
MONI HD-SDI   : MONI
TEST OUT      : VBS
RM VIDEO      : VBS
```

COLOR

With COLOR, all R, G, and B channels will be output. Single-channel output of R, G, or B is also possible.

MONI HD-SDI

The signals to be monitored with video monitors connected to the MONITOR OUT HD SDI 1/2 connectors can be selected.

Setting	Signal
MONI	Regardless of the VF1/VF2 settings, characters or the marker can be added independently to the video output signals. (Default)
VF1	Video signals that are output to the VF1 connector (camera images with character data for the setting menus and status display)
VF2	Video signals that are output to the VF2 connector

TEST OUT

The signals to be output to a video monitor or waveform monitor connected via the TEST OUT connector can be selected.

Setting	Signal
VBS	The VBS signals are output. (Default)
VF2	The HD-Y signals are output.
REF-THRU	The reference signal that is input to the GENLOCK IN connector is output as-is.
FRAME	A pulse is output per frame (in a case of 1 FPS, one pulse per second).

Timing of the pulse signal

Example 1: SHUTTER OFF

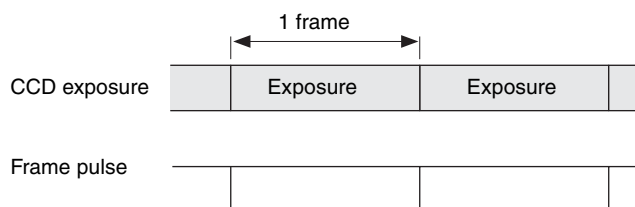

Example 2: SHUTTER ON, shutter angle 180°

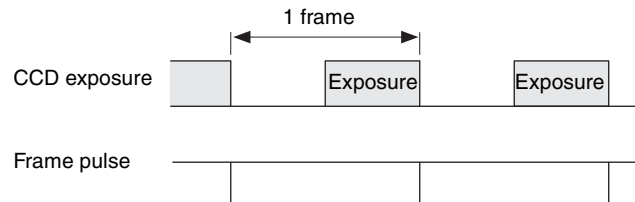

RM VIDEO

The video signals to be output to equipment connected via the REMOTE connector can be selected.

Setting	Signal
VBS	The VBS signals are output. (Default)
VF2	The HD-Y signals are output.

3-5-2 Setting the Monitor Picture

Using the <PB/MONI GAMMA> page of the USER (OPERATION) menu displayed on the viewfinder screen, the gamma setting of the monitor picture and the playback-picture monitor mode can be selected.

<PB/MONI GAMMA> page

```
<PB/MONI GAMMA> 08
MONI GAMMA ENABLE : OFF
                   VF  MONI  VBS
PB   : ▶ OFF  OFF  OFF
PB MIX : OFF  OFF  OFF

MONITOR GAMMA
VF   : OFF
MONI : OFF
VBS  : R709
GAMMA MARK SETTING
```

To apply monitor gamma to the monitor picture

MONI GAMMA ENABLE

If this is set to ON, the monitor gamma (ITU-R709) appropriate for monitoring¹⁾ is applied to the video signals output from the VF1, VF2, MONITOR OUT HD SDI 1/2, or REMOTE connector. The video output signals from those connectors are selected on the <MONITOR OUTPUT> page.

This setting is effective when S-LOG gamma is applied to the video output signals for recording intended for post-production editing.

1) The VBS output signal always becomes the camera image to which ITU-R709 gamma is applied.

Notes

- If the monitor gamma is activated with 23.98PsF/S23.98PsF, the output for viewfinders and monitors is switched to 59.94i. In the case of 24PsF/S24PsF, the output is switched to 50i. To eliminate this phenomena, change the DOWN CONVERTER setting on the <POWER SAVE> page of the MAINTENANCE menu from ACTIVE to PWR SAVE.
- Some of the paint settings (such as black gamma, knee, detail, matrix, etc.) for the main line are not applied to monitor gamma.

To monitor the playback picture

The playback picture of the recorder can be confirmed with a monitor connected to the camera or on the viewfinder screen.²⁾

2) When MONI GAMMA ENABLE is set to OFF, the same gamma as that applied to the main line is applied to all the outputs. However, the PB and PB MIX modes can be independently selected for the VF, MONI, and VBS signals.

PB

The playback-signal output mode can be selected for each VF, MONI, or VBS signal.

Setting	Signal
ON	The playback picture of the recorder is always output.
AUTO	Normally, the camera image is output. When the recorder enters playback mode (PLAY, FF, REW, or REC REVIEW,) the playback picture is automatically selected.
OFF	The camera image is always output. (Default)

Note

If the recorder is turned off with PB ON, the picture on the viewfinder/monitor screen is distorted. The normal picture is restored by turning the recorder on or setting PB to AUTO or OFF.

To compare the playback picture and camera image

The playback picture and camera image can be displayed on the same screen when the playback-signal output mode is set to ON or AUTO for the item PB on the <PB/MONI GAMMA> page and if PB MIX is set to ON.

PB MIX

The playback-signal mix mode can be independently set to ON or OFF for each VF, MONI, or VBS signal. When set to ON, the playback picture and camera image are mixed.

How this is to be displayed can be set on the <PB MIX SETTING> page of the USER (OPERATION) menu.

<PB MIX SETTING> page

<PB MIX SETTING> U08	
MIX TYPE	: ►MIX
MIX DIRECTION	: PB
MODE	: Y-MIX
LEVEL	: 80%
WIPE LAYOUT	: HOR
PB POSITION	: RIGHT
BOUNDARY	: 960

MIX TYPE

How the picture is to be displayed can be selected.

Setting	How to display
MIX	The playback picture and camera image are overlapped. (Default)
WIPE	The screen is horizontally or vertically split in two, and two pictures are displayed simultaneously.

MIX

When MIX TYPE is set to MIX, how to mix the pictures can be selected.

Item	Setting	Content
DIRECTION	CAM	The playback picture is gradually mixed into the camera image. (Default)
	PB	The camera image is gradually mixed into the playback picture.
MODE	Y-MIX	The Y signals are mixed. (Default)
	WIRE(W)	Only the outline components are mixed and displayed with white lines.
	WIRE(B)	Only the outline components are mixed and displayed with black lines.
LEVEL	0 to 80%	The mix level can be adjusted. (Default: 80%)

WIPE

When MIX TYPE is set to WIPE, how pictures are to be wiped can be selected.

Item	Setting	Content
LAYOUT	HOR	Horizontally split (Default)
	VERT	Vertically split
PB POSITION	RIGHT	With HOR, the playback picture is displayed on the right and the camera image on the left. (Default when HOR is selected)
	LEFT	With HOR, the playback picture is displayed on the left and the camera image on the right.
	BOTTOM	With VERT, the playback picture is displayed in the lower part and the camera image in the upper part. (Default when VERT is selected)
	TOP	With VERT, the playback picture is displayed in the upper part and the camera image in the lower part.
BOUNDARY	With HOR: 0-1920 With VERT: 0-1080	The boundary position can be changed. (Default: with HOR: 960, with VERT: 540)

To display the gamma mark

GAMMA MARK SETTING

When monitor gamma (ITU-R709) is applied to the SDI output at the MONITOR OUT connectors and the viewfinder images, you can set the camera to display the gamma mark (709 γ) to indicate that gamma that is different from that used for recording is applied. (The mark is not recorded with the docked recorder.)

Select GAMMA MARK SETTING on the <PB/MONI GAMMA> page to jump to the subpage for setting the gamma mark.

<GAMMA MARK> page

<GAMMA MARK>	ESC
MONI GAMMA MARK :	▶ ON
MARK LEVEL :	3
H POSITION :	0
V POSITION :	0

Set MONI GAMMA MARK to ON then set the brightness and position of the indication.

Item	Function
MARK LEVEL	For selecting the brightness of the gamma mark among 1-4 (4 for the maximum brightness)
H POSITION	For setting the horizontal position of the indication in the range of 0-99 (0 for the leftmost)
V POSITION	For setting the vertical position of the indication in the range of 0-99 (0 for the uppermost)

3-5-3 Outputting Color Bars

The color-bar signal can be output by setting the color-bar generator built in the camera to ON.

The color-bar generator can be turned ON or OFF on the <OTHERS 1> page of the USER (MAINTENANCE) menu.

<OTHERS 1> page

<OTHERS 1>	U20
FAN MODE	: AUTO1
CAM BARS	: ▶ ON
HD-BAR (VF/MONI)	
BAR 16:9 (100%)	
SD-BAR	
SMPTE	
IMAGE INVERT	: OFF
IRIS CLOSE	: OFF
MONI REMOTE REC	: OFF

When CAM BARS is set to ON, the color-bar generator is turned ON, and the color-bar signal is output.

As the HD and SD (VBS) outputs for the viewfinders and monitors, the format of the color-bar signals can be independently selected.

The color-bar signal format for the camera output of the main line is fixed at 16:9 (100%), regardless of the settings of the above outputs.

HD-BAR (VF MONI)

The format of the color-bar signals sent to the VF1, VF2, and MONITOR OUT HD-SDI connectors can be selected from among the 17 types.

SD-BAR

The format of the color-bar signals to the TEST OUT and REMOTE connectors can be selected from among the 5 types.

Item	Selectable color-bar formats
HD-BAR (VF/MONI)	BAR 16:9 (100%), BAR 16:9 (75%), SMPTE 16:9 (BLACK), SMPTE 16:9 (-I/Q), BAR 4:3 (100%), BAR 4:3 (75%), SMPTE 4:3 (BLACK), SMPTE 4:3 (-I/Q), MF-ARIB (75%), MF-ARIB (100%), MF-ARIB (+I), MF-SMPTE (-I, Q), MF-SMPTE (75%, Q), MF-SMPTE (100%, Q), MF-SMPTE (+I, Q), HD-CUSTOM, HD-CUSTOM2
SD-BAR	SMPTE, EIA, FULL (EBU), 95%, NTSC100% (PAL100%)

Note

The color-bar signal is not output with the video output from the VF1, VF2, MONITOR OUT HD SDI 1/2, and REMOTE connectors if the monitor gamma (R709) is selected for MONITOR GAMMA of the respective output on the <PB/MONI GAMMA> page (except when a VBS signal is output).

3-6 Viewing and Setting the Viewfinder Displays

Besides the video image, the viewfinder can display text and messages showing the camera settings and operation status.

The same information can be displayed on monitors connected to the MONITOR OUT HD SDI connectors.

Note

This information is not displayed when the camera is in Menu Operation mode. Exit Menu Operation mode to view the information.

3-6-1 Viewing the Basic Status Indications

The following status indications can be superimposed on the camera picture when you press the VF MENU/DISPLAY button.

The display conditions can be specified on the <VF DISPLAY> page of the USER (OPERATION) menu.

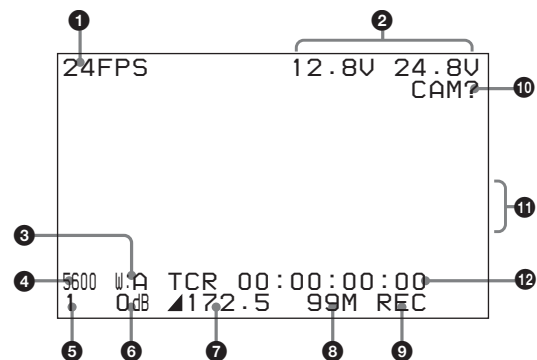
**1 Frame rate**

The current frame rate is displayed.

2 Battery indications

The conditions of output power are indicated. The left column is for DC 12V OUT power and the right column is for DC 24 V OUT power.

Each indication begins to flash if the corresponding input voltage decreases to the NEAR END value specified on the <BATT ALARM SET> page of the MAINTENANCE menu.

Flashing becomes quicker as the voltage decreases further toward the END value.

The set NEAR END and END values can be checked on the <BATTERY ALARM> page of the USER (OPERATION) menu.

3 White balance memory

Displays the currently selected white balance memory.

W:A: Memory A

W:B: Memory B

W:P: Preset memory

The setting is fixed at W:P in Cine mode.

In Custom mode, you can change the setting using the subdisplay or from a remote control unit.

4 Color temperature filter mode

Indicates the condition of the electrical filter.

In Cine mode, “5600” is displayed when the daylight filter is selected. When the tungsten filter is selected, this column becomes blank.

In Custom mode, “5600” is displayed when 5600K is set to ON.

5 Optical filters

Displays the types of filters currently selected.

6 Gain value

Displays the video gain value (dB) of the video amplifier.

7 Shutter

The shutter setting is displayed with the shutter angle or frequency. For a shutter angle, ▲ is displayed at the left. The type of the display, angle (deg) or speed (sec), can also be switched on the <VF DISPLAY> page of the USER (OPERATION) menu (default: deg).

8 Tape remaining

The remaining time of the tape of the recorder docked on the camera is roughly indicated in minutes.

9 Recording mode

“REC” is displayed when the recorder docked on the camera is in REC mode.

10 Self-diagnosis information

“CAM?” is displayed if an error is generated, e.g., on an internal board, and an error message appears in the message area.

This indication cannot be set to OFF.

For the error messages, see “Warning/Error Messages” (page 114).

11 Message area

Displays the status of auto setup, error messages, etc.

12 Time code area

Displays the same time codes as those on the subdisplay.

For details, see “3-2-8 Confirmation of the Time Code and Tape Remaining” (page 38).

Setting the basic status indications

The conditions for displaying the basic status indications can be set on the <VF DISPLAY> page of the USER (OPERATION) menu.

<VF DISPLAY> page

<VF DISPLAY>		U01	
FPS	:▶ ON	GAIN	: ON
ND	: ON	SHUTT	: ON
5600K	: ON	UNIT	: deg
WHITE	: OFF	BATT12	: OFF
		BATT24	: OFF
		REC	: OFF
		TAPE	: OFF
		TC	: OFF
		MESSAG	: ALL

Item	Setting
FPS	Set to ON to obtain the frame rate indication ❶.
ND	Set to ON to obtain the optical filter indications ❷.
5600K	Set to ON to obtain the 5600 indication ❸.
WHITE	Set to ON to obtain the white balance memory indication ❹.
GAIN	Set to ON to obtain the gain value indication ❺.
SHUTT	Set to ON to obtain the shutter indication ❻.
UNIT	Select the unit for the shutter indication. deg: Shutter angle (Default) sec: Shutter speed
BATT12	Set to ON to obtain the battery indications ❼.
BATT24	
REC	Set to ON to obtain the recording mode indication ❽.
TAPE	Set to ON to obtain the tape remaining indication ❾.
TC	Set to ON to obtain the time code indication ❿.
MESSAG	Select the type of messages to be displayed in the message area ⓫. ALL: To display all messages AT: To display Auto Setup information and higher WRN: To display warning messages and higher OFF: To display warning messages of the highest level only

3-6-2 Viewing the ABNORMAL <!> Display

Pressing the CANCEL/STATUS button calls the following ABNORMAL<!> display, permitting you to check the items for which the setting is not in the normal condition.

Example: Safety zone marker (90%)

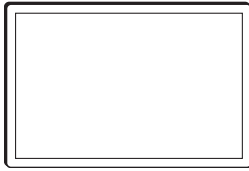

The <CHAR/MARK MIX> page and <MARKER SETTING> page of the USER (OPERATION) menu allow you to switch the display of the markers on or off and to set the display conditions of the markers.

Activating/deactivating all the marker indications for each output

The <CHAR/MARK MIX> page permits you to activate and deactivate the marker indications for each output.

<CHAR/MARK MIX> page

```

<CHAR/MARK MIX> U09
      VF1 VF2 MONI VBS
CHAR  : ON  ON  ON  ON
MARKER: ON  ON  ON  ON
CURSOR: OFF OFF OFF OFF
ZEBRA : OFF OFF OFF OFF

CHAR/MARK LEVEL : 50
VF GATE MARKER  : OFF
    
```

The MARKER indications are activated for all the outputs at the factory.

Item	Setting
VF1	Turn all the markers on or off on the viewfinder connected to the VF1 connector.
VF2	Turn all the markers on or off on the viewfinder connected to the VF2 connector.
MONI	Turn all the markers on or off on the monitors connected via the MONITOR OUT connectors.
VBS	Turn all the markers on or off on the monitors connected via the TEST OUT and REMOTE connectors.

The CHAR/MARK LEVEL line permits you to adjust the brightness (0 to 50) of the character and marker indications.

Specifying the markers to be displayed

For the outputs for the total marker indication is activated on the <CHAR/MARK MIX> page, select and adjust the marker(s) to be displayed on the next <MARKER SETTING> page.

<MARKER SETTING> page

```

<MARKER SETTING> U03
CENTER      : OFF  1
SAFETY      : OFF  90.0%
EFFECTIVE   : OFF
ASPECT      : OFF  4:3
VARIABLE    : --
SAFETY      : OFF  90.0%
MASK        : OFF  12
CURSOR      : BOX
POSITION    : 0    0
SIZE W/H    : 960  540
    
```

All the markers have been set to OFF at the factory.

Item	Setting
CENTER	Set to ON to display the center marker and select the type of the center marker. 1: Entire cross 2: Entire cross with a hole 3: Center 4: Center with a hole
SAFETY	Set to ON to display the safety zone marker and specify the range (80%, 90%, 92.5%, or 95%).
EFFECTIVE	Set to ON to display the effective pixel area.
ASPECT	Set to ON to display the aspect marker and specify the aspect: 2.40:1, 2.35:1, 1.85:1, 1.66:1, 16:9, 15:9, 14:9, 13:9, 4:3, VAR H, VAR V
VARIABLE	If you select VAR H or VAR V for ASPECT, set the H or V value. VAR H: 12 to 1920 VAR V: 12 to 1080
SAFETY	Set to ON to display the safety zone for the selected aspect marker, and specify the range.
MASK	Set to ON to make the areas outside the selected aspect marker dimmer, and select the mask level (0 to 15).

3-6-5 Adjusting the Viewfinder Details

You can adjust the image on the viewfinder screen to obtain a clearer view, using the <VF DETAIL> page of the USER (OPERATION) menu. This adjustment does not affect the image being recorded.

<VF DETAIL> page

```

<VF DETAIL>          U04
VF 1      :▶ OFF
VF 2      :  OFF
LEVEL     :    25%
CRISP     :     0

```

Item	Function
VF1	Turn the VF detail adjustment function on or off for the viewfinder connected to the VF1 connector.
VF2	Turn the VF detail adjustment function on or off for the viewfinder connected to the VF2 connector.
LEVEL	Set the level (0 to 100%) of the VF detail adjustment function.
CRISP	Set the noise crispering level (-99 to 99).

3-6-6 Setting the Zebra Indication

You can display a zebra pattern(s) on the viewfinder and monitor screen.

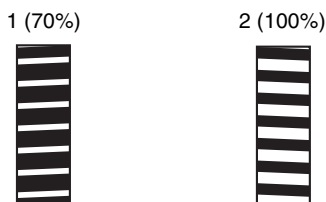
Zebra (default settings)

Setting the zebra indication is performed on the <ZEBRA> page of the USER (OPERATION) menu.

<ZEBRA> page

```

<ZEBRA>              U05
VF 1      :▶ OFF
VF 2      :  OFF
MONITOR   :  OFF
UBS       :  OFF

ZEBRA TYPE :     1
ZEBRA1 LEVEL:   70%
          WIDTH:   10%
ZEBRA2     :   100%

```

Item	Function
VF1 ¹⁾	Turn the zebra indication on the viewfinder connected to the VF1 connector on/off.
VF2 ¹⁾	Turn the zebra indication on the viewfinder connected to the VF2 connector on/off.
MONITOR ¹⁾	Turn the zebra indication on the monitors connected to the MONITOR OUT connectors on/off.
VBS ¹⁾	Turn the zebra indication on a device connected via the REMOTE connector on/off.
ZEBRA TYPE	Select the zebra(s) to be displayed: 1, 2, or 1&2
ZEBRA1 LEVEL	Adjust the level (0 to 109%) of the zebra 1 indication (factory setting: 70%).
WIDTH	Adjust the width (0 to 30%) of the zebra 1 indication (factory setting: 10%).
ZEBRA2	Adjust the level (50 to 109%) of the zebra 2 indication (factory setting: 100%).

1) These items can also be set on the <CHAR/MARK MIX> page.

3-6-7 Setting the Cursor Indication

You can display a cursor on the viewfinder and monitor screen.

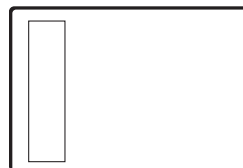
Example: Box cursor**Activating/deactivating the cursor indication**

The <CHAR/MARK MIX> page of the USER (OPERATION) menu permits you to activate/deactivate the cursor indication for each output.

<CHAR/MARK MIX> page

```

<CHAR/MARK MIX>     U09
CHAR      : VF1 VF2 MONI VBS
MARKER    : ON  ON  ON  ON
CURSOR    :▶OFF OFF OFF OFF
ZEBRA     : OFF OFF OFF  OFF

CHAR/MARK LEVEL : 50
VF GATE MARKER  : OFF

```

The CURSOR indication is deactivated for all the outputs at the factory.

Menu item	Function
VF1	Turn the cursor indication on the viewfinder connected to the VF1 connector on/off.
VF2	Turn the cursor indication on the viewfinder connected to the VF2 connector on/off.
MONI	Turn the cursor indication on the monitors connected to the MONITOR OUT connectors on/off.

Setting the type and size of the cursor

For the outputs for which you activate the cursor indication on the <CHAR/MARK MIX> page, select and adjust the cursor to be displayed on the next <MARKER SETTING> page.

<MARKER SETTING> page

```

<MARKER SETTING> U03
CENTER      : OFF   1
SAFETY      : OFF  90.0%
EFFECTIVE   : OFF
ASPECT      : OFF  4:3
VARIABLE    : --
SAFETY      : OFF  90.0%
MASK        : OFF  12
CURSOR      : ►BOX
POSI H/U    :      0      0
SIZE W/H    : 960    540
  
```

Menu item	Function
CURSOR	Select the type (BOX/CROSS) of the cursor to be displayed.
POSI H/V	Adjust the H (horizontal) position (–958 to 956) and the V (vertical) position (–538 to 536) of the center.
SIZE W/H	Adjust the width (from the center to right or left side) (16 to 1920) and the height (from the center to top or bottom) (16 to 1080) of the cursor.

3-6-8 Checking the Power Voltage

The settings of the NEAR END and END values to warn of low voltage of a power supply can be checked on the <BATTERY ALARM> page of the USER (OPERATION) menu.

<BATTERY ALARM> page

```

<BATTERY ALARM> U15
DC IN (24V)  24.2V
TYPE : ►AC ADP
NEAR END    : (22.2)
END         : (21.6)

DC IN (12V)  12.8V
TYPE : AC ADP
NEAR END    : (11.1)
END         : (10.8)
  
```

Menu item	Indication
DC IN (24V)	Voltage of the 24-V power
TYPE	Select the type of the 24-V power source.
NEAR END	NEAR END value specified for the 24-V power source of the selected type
END	END value specified for the 24-V power source of the selected type
DC IN (12V)	Voltage of the 12-V power
TYPE	Select the type of the 12-V power source.
NEAR END	NEAR END value specified for the 12-V power source of the selected type
END	END value specified for the 12-V power source of the selected type

This page is intended for display only. You can only switch the type. If you want to change the values, use the <BATT ALARM SET> page of the MAINTENANCE menu.

3-7 Detailed Settings of the Switch Functions

By using the <SWITCH ASSIGN> page of the USER (OPERATION) menu displayed on the viewfinder/monitor screen, the operation mode of the MENU SEL/ENTER dial in addition to function assignment to the assignable buttons/switch that can also be made on the subdisplay.

<SWITCH ASSIGN> page

```

<SWITCH ASSIGN>  U13
ASSIGN SW1  : ▶OFF
ASSIGN SW2  :  OFF
ASSIGN SW3  :  OFF
ASSIGN SW4  :  OFF
RE_ROTATION:  STD
  
```

Assigning functions to the assignable buttons/switch

When you position the pointer to any of the ASSIGN SW1 to ASSIGN SW4 lines and push on the MENU SEL/ENTER dial, the subpage to set the corresponding button/switch is displayed.

You can assign the same functions as those when you operate the subdisplay.

For the assignable functions, see “3-2-11 Allocation of Functions to the Assignable Buttons and Switch” (page 39).

Setting subpage for assignable button 1

```

ASSIGN SW1      ESC
▶OFF
ND
REC REVIEW
PB(VF)
VF709GAM
MONI709GAM
FAN MODE
GAIN -9/-18dB
  
```

The setting subpages for button 2 and 3 have the same layout as that for button 1.

Setting subpage for assignable switch 4

```

ASSIGN SW4      ESC
▶OFF
AWB
BARS
TEST1
  
```

Position the pointer to the function to be assigned and push on the MENU SEL/ENTER dial.

Setting the operation mode of the MENU SEL/ENTER dial

You can reverse the operation corresponding to the directions of rotation of the MENU SEL/ENTER dial on the camera head and that on the assistant panel.

Setting	Operation
STD (default)	Clockwise rotation moves the pointer/cursor down or increases values on a menu/subdisplay page.
RVS	Clockwise rotation moves the pointer/cursor up or decreases values on a menu/subdisplay page.

3-8 Setting the Gain

If the gain of the video amplifier of this camera is to be switched using the gain switch of the RM-B150 Remote Control Unit, the gain values for the corresponding switch positions must be specified in advance.

Use the <GAIN ASSIGN> page of the USER (OPERATION) menu.

<GAIN ASSIGN> page

```

<GAIN ASSIGN>      U14
GAIN [L]:▶ 0 dB
[M]: 6 dB
[H]: 12 dB
  
```

Menu item	Setting
GAIN [L]	Gain value corresponding to the L position of the gain switch
GAIN [M]	Gain value corresponding to the M position of the gain switch
GAIN [H]	Gain value corresponding to the H position of the gain switch

Any of -6, -3, 0, 3, 6, 9, or 12 dB can be set for each of the L, M, and H positions, in any sequence.

3-9 Detailed Shutter Settings

The Electronic Shutter function of this camera enables shooting with various shutter angles and shutter speeds (sec).

While the basic settings of the shutter can be made on the subdisplay, the <SHUTTER/FPS> page of the USER (PAINT) menu permits you to set the shutter while observing the shutter angle, the shutter speed (sec), and the frame rates at a glance.

<SHUTTER/FPS> page

```

<SHUTTER/FPS>    U19
SHUTTER :▶ ON
           [deg]  [sec]
           180.0 (1/47.96)
STEP
CONTINUOUS
STEP ASSIGN
ADD DELETE
FRAME RATE : (24)FPS
COMP MODE : OFF
  
```

SHUTTER

To activate the electronic shutter, set this to ON. The currently selected shutter angle is displayed in the [deg] column. In the [sec] column, the speed (sec) converted according to the selected frame rate is displayed.

STEP (Step mode)

To select a value registered as a step shutter, move the cursor on this line. Turn the MENU SEL/ENTER dial to display a registered shutter value in the [deg] and [sec] columns one after another in order.

CONTINUOUS (Continuous mode)

To fine-adjust the selected step shutter value or use a value that has not been registered as a step shutter, move the cursor on this line. The values in the [deg] and [sec] columns will change continuously when the MENU SEL/ENTER dial is turned.

STEP ASSIGN

Addition and deletion of step shutter values can be performed in the same way as with the SHUTTER ASSIGN page (*see page 34*) of the USER (OPERATION) menu.

• ADD

For registering a shutter value displayed in the [deg] column in Continuous mode as a new step shutter value. If eight step shutter values have been already registered,

“STEPS FULL” will be displayed, and the value will not be added. In such a case, delete an unneeded step shutter value beforehand, using DELETE.

- **DELETE**

For deleting the step shutter value displayed in the [deg] column in Step mode.

For additional information of the step shutter, see “3-2-2 Shutter Settings” on page 33.

FRAME RATE

Select the frame rate (number of frames per second) if a format of “Select FPS” is selected.

The selecting range depends on the formats, as follows:

Selected format	Selectable frame rates
S23.98PsF/S24PsF	1 to 24 FPS (frames per second)
S25PsF	1 to 25 FPS
S29.97PsF/S30PsF	1 to 30 FPS
S50P/S59.94P/S60P	1 to 50 FPS

If a format other than formats of “Select FPS” has been selected, the value is indicated in parentheses and cannot be changed.

COMP MODE

This camera enables you to compensate for changes in the video level when the FPS value is changed.

Two compensation modes are provided: one that depends on shutter angles and another that depends on electric gain.

- **ANGLE: Angle Compensation mode**

When you change the frame rate, the shutter angle is automatically corrected, retaining the video level.

Notes

- In Angle Compensation mode, the frame rate cannot be changed to a lower value if the shutter angle comes to near 0°, and it cannot be changed to a higher value if the shutter angle comes to near 360°.
- When you activate Angle Compensation mode, the shutter setting is automatically set to ON.

- **GAIN: Gain Compensation mode**

When you change the frame rate, the electric gain is automatically corrected, retaining the video level. The current shutter angle setting is maintained.

Notes

- Care must be taken when shooting a high-contrast subject, as the dynamic range (latitude) may be degraded to $1/2$ at maximum, depending on the selected video format or FPS.
- With the default settings, the range of the frame frequencies that can be selected with the Select FPS

function (see page 59) is limited. With COMP MODE set to OFF or ANGLE, frame frequencies of 8 FPS or less are not available to minimize picture degradation. Usage under FPS will increase noise on the picture. To lift this limitation, change the FPS LIMITER setting on the <OTHERS 2> page of the MAINTENANCE menu from LIMIT to FREE.

If the setting is changed from FREE to LIMIT, COMP MODE will be forcibly set to OFF.

3-10 Resuming the Standard Conditions

The <OPERATOR FILE> page of the USER (OPERATION) menu permits you to return the operation items (those contained on pages U02 to U14 of the factory-preset USER menu) you changed to the factory-set statuses.

<OPERATOR FILE> page

```

<OPERATOR FILE> U16
  READ  (MS →CAM)
  WRITE (CAM→MS )
  ▶PRESET

FILE ID:
CAM CODE
DATE
  
```

Position the pointer to PRESET and push on the MENU SEL/ENTER dial. The operation items return to the statuses stored in the operator file.

For details on the operator file, see “Chapter 5 Storage and Retrieval of User Setting Data”.

3-11 Selecting the Gamma

You can use User gamma you create in addition to the built-in Standard gamma and Hyper gamma. Use the <GAMMA> page of the USER (PAINT) menu for gamma operations.

<GAMMA> page

```

<GAMMA> U18
TABLE  :▶USER
        : 1 S-LOG A
TEST   : OFF
  
```

Gamma selection is also possible on the gamma-table selection page of the subdisplay.

3-11-1 Using the Standard Gamma

Standard Gamma is for video and intended to be used mainly for creating broadcast contents. It is used in combination with the Knee function that adjusts the dynamic range of high-luminance areas. When STANDARD is selected on the first line of TABLE of the <GAMMA> page, you can select from among the following standard gamma curves:

Gamma table No.	Gamma curve
1	equivalent to SD ENG camcorder
2	equivalent to 4.5-times gain
3	equivalent to 3.5-times gain
4	equivalent to SMPTE-240M
5	equivalent to ITU-R709
6	equivalent to 5.0-times gain

It is recommended to use the No. 5 (ITU-R709) curve in normal use.

As ITU-R709 provides 4.5-times gain around the black, select the No. 6 (×5) curve when you need higher contrast around the black.

3-11-2 Using the Hyper Gamma

Hyper Gamma enables the wide dynamic range of the CCD sensors to be reproduced in smooth contrast without using the knee function.

You can easily adjust whether to widely reproduce high contrast or to brightly reproduce the luminance of the intermediate tones by selecting an appropriate curve. Settings assuming usage of postproduction devices having a white limit of 100% are also provided.

- 1 Select HYPER on the first line of TABLE on the <GAMMA> page, and select the hyper gamma table most suitable to the shooting conditions and purpose.

Effective for shooting for brighter tonal reproduction around the skin of the subject	Effective for shooting a high-contrast subject
Hyper Gamma 3 (HG3) Compressing 325% to 109%	Hyper Gamma 4 (HG4) Compressing 460% to 109%
Hyper Gamma 1 (HG1) Compressing 325% to 100%	Hyper Gamma 2 (HG2) Compressing 460% to 100%

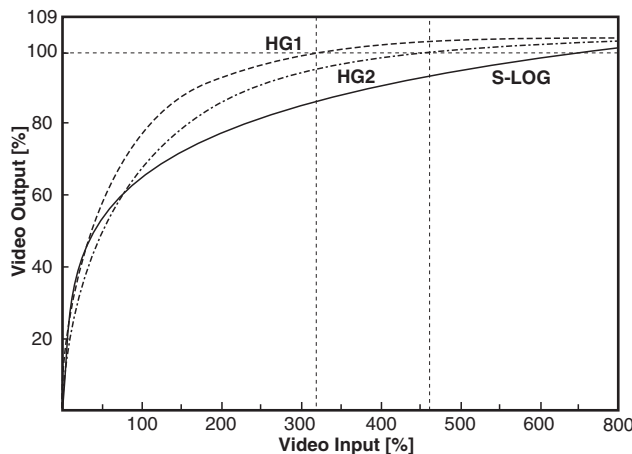
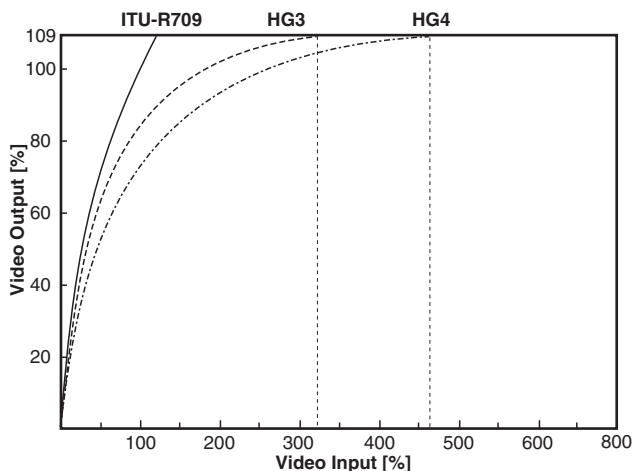

These curves are equivalent to those built into the HDW-F900R HD Camcorder.

- 2 Call the <WHITE CLIP> page of the PAINT menu and adjust the white clip level to fit the selected hyper gamma.

3-11-3 Using the S-LOG

When SPECIAL is selected on the first line of TABLE on the <GAMMA> page, the second line indicates S-LOG (Sony Log).

Sony Log (S-LOG in subsequent texts) is a gamma which assumes use in the DI workflow (capturing filmed negative images and creating a digital master through digital processing for screening) in cinema production. S-LOG enables you to monitor the latitude close to negative film and perform the timing (color correction) with a Sony digital cinema camera, achieving “Digital Negative” that is the optimum negative film work flow for digital processing.

With this “Digital Negative” you can have the conventional shooting style, using ISO sensitivity, luminometer and the wide latitude of negative film, enabling smooth transition from film production to digital cinema production.

Detailed information of S-LOG is described in the “SONY-LOG Whitepaper.”

For the “SONY-LOG Whitepaper,” consult your local Sony representative.

3-11-4 Using the User Gamma

You can also create a desired gamma table, using a personal computer on which software CvpFileEditor™¹⁾ has been installed and load the table into the camera via a “Memory Stick.”

When a user gamma table is selected, control of gamma (LEVEL or ON/OFF) may become disabled, depending on data of the table. This is because the gamma and knee are compulsorily fixed when creating the gamma curve.

User gamma curves are initialized with S-LOG at the factory. (The characteristic data of S-LOG can be output in files, using the CvpFileEditor.)

1) CvpFileEditor is a trademark of Sony Corporation.

To select the user gamma

- 1 To use the gamma table you have created, load it into the camera.

Load the gamma table data via a “Memory Stick” using the <USER GAMMA> page of the FILE menu in Custom mode.

<USER GAMMA> page

```
<USER GAMMA>      F04 TOP
  →READ (MS →CAM)

FILE ID
CAM CODE
DATE
```

For details on file operations, see “Chapter 5 Storage and Retrieval of User Setting Data”.

2 Select the user gamma.

Select USER on the first line of TABLE on the <GAMMA> page of the USER (PAINT) menu and display the desired user gamma.

A user gamma for which the black level has been set to “0” using CvpFileEditor V4.0, the master black (BLACK [M]) setting is fixed to “0” (factory setting), and “- -” is displayed.

CvpFileEditor

The F35 supports CvpFileEditor Version 3.0 or later. If the version of your CvpFileEditor is an earlier version, you can download the software from the “eCSite,” the site for downloading business and professional software from Sony Corporation.

If you have not registered at “eCSite,” access the following URL and register.

<https://www.ecspert.sony.biz/ecsite/center/registUserInfo?action=regulationsDirect>

For detailed information on how to install the software, refer to the manual for CvpFileEditor, available from the above site.

3-12 Inverting the Camera Picture

The image-inversion function allows you to cancel the image inversion phenomena that occurs when a cine-lens converter is used.

Use the <OTHERS 1> page on the USER (MAINTENANCE) menu to access to this function.

<OTHERS 1> page

```
<OTHERS 1>      U20
FAN MODE          : AUTO1
CAM BARS          : OFF
HD-BAR (VF/MONI) :
  BAR 16:9 (100%)
SD-BAR
SMPTE
IMAGE INVERT     : ►OFF
IRIS CLOSE       : OFF
MONI REMOTE REC  : OFF
```

Set IMAGE INVERT to ON to activate the image-inversion function. The upside of the picture comes down, swapping the right and left.

3-13 Detailed Setting of the Video Format

You can select various video formats according to that of the video recorder used in combination.

Available formats

Frame rate	Signal format	Frame rate	Signal format
23.98PsF	4:2:2 YCbCr	S29.97PsF	4:2:2 YCbCr
	4:4:4 RGB		4:4:4 RGB
S23.98PsF	4:2:2 YCbCr	50P	4:2:2 YCbCr
	4:4:4 RGB		4:4:4 RGB ¹⁾
24PsF	4:2:2 YCbCr	S50P	4:2:2 YCbCr
	4:4:4 RGB		4:4:4 RGB ¹⁾
S24PsF	4:2:2 YCbCr	S59.94P	4:2:2 YCbCr
	4:4:4 RGB		4:4:4 RGB
25PsF	4:2:2 YCbCr	59.94I	4:2:2 YCbCr
	4:4:4 RGB		4:4:4 RGB
S25PsF	4:2:2 YCbCr	50I	4:2:2 YCbCr
	4:4:4 RGB		4:4:4 RGB
S30PsF	4:2:2 YCbCr	S60P	4:2:2 YCbCr
	4:4:4 RGB		4:4:4 RGB ¹⁾
29.97PsF	4:2:2 YCbCr		
	4:4:4 RGB		

1) Selectable only when the HKSR-102 Picture Cache Board and the HKSR-103 RGB 60P Processor Board are mounted in the SRW-1. Outputs from the HD-SDI A/B connectors of the interface box are turned off.

You can confirm the format being selected on the FUNCTION display (page 49).

Any eight of above formats of highest need can be registered to be selected on the subdisplay.

For format selection on the subdisplay, see “3-2-4 Selection of Video Formats” (page 35).

Using the <OUTPUT FORMAT> page of the MAINTENANCE menu enables selection of the mainly used format in interface with the SRW-1 HD Portable Digital Recorder.

Frame frequency of 23.98PsF and signal format of 4:4:4 RGB have been selected at the factory.

Changing the format

Referring to the procedure mentioned in “2-9 Setting the Built-in Clock” (page 28), select MAINTENANCE menu

on the TOP MENU screen and call up the <OUTPUT FORMAT> page.

For details on menu operations, see “4-2 Basic Menu Operations” (page 61).

<OUTPUT FORMAT> page of MAINTENANCE menu

```

<OUTPUT FORMAT>  M07 TOP
CURRENT  23.98PsF  4:4:4
NEXT
SCAN      :→PROGRESSIVE
FRAME     : 23.98
SIGNAL    : 4:4:4 RGB
SELECT FPS: OFF
          SET RORMAT
    
```

CURRENT

The current format is displayed.

Specify the desired format, using the lines under NEXT.

SCAN

Select the scan mode: PROGRESSIVE or INTERLACE.

FRAME

Select the frame rate. When you select INTERLACE for the scan mode, select 29.97 to specify 59.94I or select 25 to specify 50I.

SIGNAL

Select the signal format.

SELECT FPS

Set to ON to use the Select FPS function.

For details on the Select FPS function, refer to the Operation Manual of the SRW-1 HD Portable Digital Recorder.

When the settings are completed, position the pointer at SET FORMAT and push on the MENU SEL/ENTER dial. The format is changed, and the new format is displayed on the CURRENT line.

Notes

- If you select the format in invalid combination (e.g., 60P and 4:4:4), SET FORMAT is displayed in parentheses, and the format cannot be changed.
- If the recorder refuses the format change by the above procedure, the message “UNSUPPORTED FORMAT” is displayed for three seconds.

Menu Configuration and Detailed Settings

Chapter

4

4-1 Menu Configuration

In addition to the subdisplay pages, the menus displayed on the viewfinder enable various detailed settings of the camera.

The available menus are:

USER menu

This menu can include menu pages selected from among the OPERATION, PAINT, MAINTENANCE, NETWORK, FILE, and DIAGNOSIS menus, for your convenience. Changing, adding, and deleting pages can be performed with the USER MENU CUSTOMIZE menu. The following pages are included on the factory-set USER menu:

Menu page title	USER menu No.	Source menu/Page No.
<VF DISPLAY>	U01	OPERATION 01
<'! IND>	U02	OPERATION 02
<MARKER SETTING>	U03	OPERATION 04
<VF DETAIL>	U04	OPERATION 05
<ZEBRA>	U05	OPERATION 06
<MONITOR OUTPUT>	U06	OPERATION 07
<PB MONI GAMMA>	U07	OPERATION 08
<PB MIX SETTING>	U08	OPERATION 09
<CHAR/MARK MIX>	U09	OPERATION 03
<SHUTTER ASSIGN>	U10	OPERATION 10
<SUBDISPLAY 1>	U11	OPERATION 11
<SUBDISPLAY 2>	U12	OPERATION 12
<SWITCH ASSIGN>	U13	OPERATION 13
<GAIN ASSIGN>	U14	OPERATION 14
<BATTERY ALARM>	U15	OPERATION 15
<OPERATOR FILE>	U16	OPERATION 16
<LENS FILE>	U17	OPERATION 17
<GAMMA>	U18	PAINT P03 [P02] ¹⁾

Menu page title	USER menu No.	Source menu/Page No.
<SHUTTER/FPS>	U19	PAINT P13 [P03] ¹⁾
<OTHERS 1>	U20	MAINTENANCE M14 [M10] ¹⁾

1) in Cine mode

For the items on each page, see the corresponding source menu page in the table in “4-3 Menu List” (page 64).

USER MENU CUSTOMIZE menu

This menu allows you to edit the USER menu.

For details, see “4-4 Editing the USER Menu” (page 90).

ALL menu

This menu permits you to control all items of the OPERATION, PAINT, MAINTENANCE, NETWORK, FILE, and DIAGNOSIS menus as a single menu.

OPERATION menu

This menu contains items for camera operators to operate the camera. It mainly permits viewfinder and switch settings.

For the pages and included items of the OPERATION menu, see “4-3-1 OPERATION Menu” (page 64).

PAINT menu

This menu contains items for making detailed image adjustments while using a waveform monitor to monitor the waveforms output from the camera.

For the pages and included items of the PAINT menu, see “4-3-2 PAINT Menu” (page 71).

MAINTENANCE menu

This menu contains items for performing camera maintenance operations, such as changing the system or setting infrequently used “paint” items.

For the pages and included items of the MAINTENANCE menu, see “4-3-3 MAINTENANCE Menu” (page 78).

NETWORK menu

This menu is for enabling the camera to be operated from a distance via a network cable, e.g., using the MSU-900/950 Master Setup Unit.

For the pages and included items of the NETWORK menu, see “4-3-4 NETWORK Menu” (page 84).

For the settings to use the MSU-900/950, see “Using the MSU-900/950” (page 103).

FILE menu

This menu is for performing file operations, such as storing/retrieving various menu setting data.

For the pages and included items of the FILE menu, see “4-3-5 FILE Menu” (page 85).

For details on files and file operations, see “Chapter 5 Storage and Retrieval of User Setting Data”.

DIAGNOSIS menu

This menu enables you to confirm the self-diagnostic information.

For the pages and included items of the DIAGNOSIS menu, see “4-3-6 DIAGNOSIS Menu” (page 89).

4-2 Basic Menu Operations

For menu operations, use the VF MENU/DISPLAY button, MENU SEL/ENTER dial, and CANCEL/STATUS button on the side panel of the camera head or those on the assistant panel connected to the CONTROL PANEL connector.

Turn the MENU SEL/ENTER dials for MENU SEL, or push on it for ENTER.

Operations are possible both on the side panel of the camera head and on the assistant panel. However, the LOCK switches are active only on the corresponding panels. If you wish to inhibit operations from either panel, set the LOCK switch of that panel to ON.

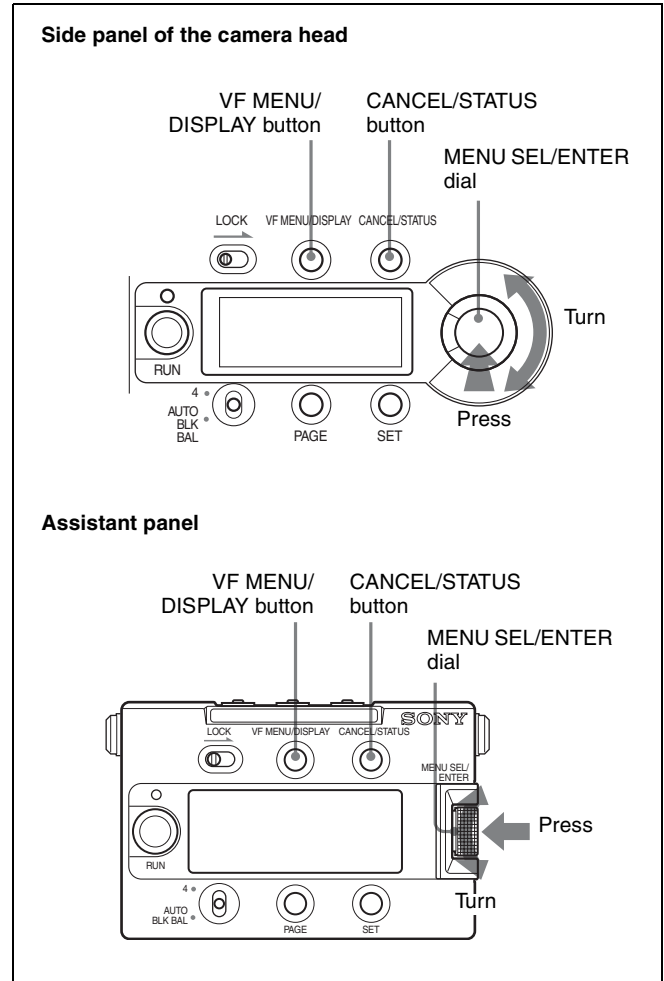

Note

When the subdisplay is in Data Change mode (? symbol shown at the right corner), menu operations on the viewfinder or monitor screen are disabled.

For settings on the subdisplay, see “3-2 Basic Settings with the Subdisplay” (page 32).

4-2-1 Displaying Setting Pages

Press the VF MENU/DISPLAY button.

The last operated menu page is displayed. (If this is your first menu operation, the CONTENTS page of the USER menu is displayed.)

The pointer on the menu screen is ► in Cine mode and → in Custom mode.

Selecting menu pages from the TOP MENU screen

If you press the VF MENU/DISPLAY button while holding the MENU SEL/ENTER dial pressed, “TOP” is displayed at the upper right corner of the screen.

Example

```
<VF DETAIL>          05→TOP
VF 1      : OFF
VF 2      : OFF
LEVEL    : 25%
```

Press the CANCEL/STATUS button, or move the pointer to “TOP” and push on the MENU SEL/ENTER dial. This displays the TOP MENU screen, which lists the available menus, and you can select the menus on this screen.

TOP MENU screen

```
<TOP MENU>
►USER
USER MENU CUSTOMIZE
ALL
•OPERATION
•PAINT
•MAINTENANCE
•NETWORK
•FILE
•DIAGNOSIS
```

- 1 Turn the MENU SEL/ENTER dial to align the pointer with the desired menu indication.
- 2 Push on the MENU SEL/ENTER dial.

The CONTENTS page or the last operated page of the selected menu is displayed.

To return to the TOP MENU screen

Press the CANCEL/STATUS button, or move the pointer to “TOP” and press the MENU SEL/ENTER dial. The TOP MENU screen is restored.

To disable the “TOP” indication

Turn the power once off then on again, or push on the MENU SEL/ENTER dial while holding the CANCEL/STATUS button pressed. This disables the TOP selection. Each time you turn the power off, the TOP selection is disabled, setting the camera to a state where only the USER menu (page 60) can be accessed.

You can arrange the USER menu so that it includes pages and items you use most frequently.

See “4-4 Editing the USER Menu” (page 90).

Selecting a page from a CONTENTS page

CONTENTS page (e.g.: USER menu)

Pointer

If the screen can be scrolled, arrows will indicate the direction of scrolling.

```
CONTENTS    U00
01.<VF DISPLAY>
02.<'!' IND>
03.<MARKER SETTING>
04.<VF DETAIL>
05.<ZEBRA>
06.<MONITOR OUTPUT>
07.<PB/MONI GAMMA>
08.<PB MIX SETTING>
09.<CHAR/MARK MIX>
10.<SHUTTER ASSIGN>
```

Turn the MENU SEL/ENTER dial to align the pointer with the desired page indication then push on the MENU SEL/ENTER dial.

The selected page is displayed.

Page number

```
<VF DETAIL>          →04
VF 1      : OFF
VF 2      : OFF
LEVEL    : 25%
CRISP     : 0
```

Changing the displayed page

- 1 Check that the pointer is located at the left of the page number then push on the MENU SEL/ENTER dial.

The pointer changes to a flashing question mark (? symbol).

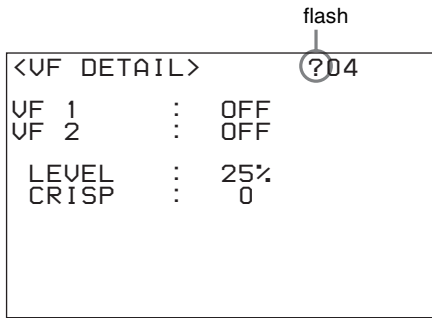

2 Turn the MENU SEL/ENTER dial to flip through the pages.

3 When the desired page is displayed, push on the MENU SEL/ENTER dial.

The “?” symbol will change back to the pointer (→ or ►), and operations with the displayed page will be enabled.

4-2-2 Setting the Menu Items

If a “?” symbol is flashing at the left of the page number, push on the MENU SEL/ENTER dial to change it to the pointer (→ or ►). Making settings on the displayed page is then enabled.

Changing the setting

1 Turn the MENU SEL/ENTER dial to align the pointer with the desired item.

2 Push on the MENU SEL/ENTER dial.

The pointer will change to a flashing “?” symbol.

3 Turn the MENU SEL/ENTER dial to change the setting value.

When the knob is rotated quickly, the values will change quickly; when rotated slowly, the values will change slowly.

To reset a changed value

If you press the CANCEL/STATUS button before pushing on the MENU SEL/ENTER dial, the setting will be returned to its previous value.

To interrupt settings

Press the VF MENU/DISPLAY button to turn off the menu screen display.

The setting operation can be restarted by setting the VF MENU/DISPLAY button again.

4 Push on the MENU SEL/ENTER dial.

The “?” symbol will change back to the pointer (→ or ►), and the new setting will be registered.

5 To change other setting items on the same menu page, repeat steps **1** through **4**.

Specifying a character string

When you push on the MENU SEL/ENTER dial with the pointer pointing to an item for which a character string, such as a file ID, is to be specified, a cursor and the list of selectable characters are displayed.

The displayed cursor can be moved by rotating the MENU SEL/ENTER dial.

1 Move the cursor to the position where you wish enter a character then push on the MENU SEL/ENTER dial.

Another cursor appears on the character list.

2 Position the cursor to the character to be entered and push on the MENU SEL/ENTER dial.

Repeat steps **1** and **2**.

By selecting INS on the line below the character list, you can enter a space at the cursor position.

Selecting DEL deletes the character at the cursor position.

You can return to step **1** without changing the character by selecting RET.

If you enter the permitted maximum number of characters (up to the stop mark at the right end of the line), the cursor moves to ESC on the line below the character list.

To register the new string you have set, select END and push on the MENU SEL/ENTER dial.

To restore the previous string, select ESC and push on the MENU SEL/ENTER dial.

Ending menu operations

Press the VF MENU/DISPLAY button.

4-3 Menu List

This section shows the menus to be displayed on the viewfinder in tables.

- For the pages that have been registered in the USER menu at the factory, the USER menu page numbers are indicated in parentheses in the No. column of the tables.

- A CONTENTS page (numbered 00) is also provided for each menu.

4-3-1 OPERATION Menu

The OPERATION menu items can be set in both Cine and Custom modes.

Execute by ENTER. : Execute by pushing on the MENU SEL/ENTER dial.

OPERATION menu					
Page title & purpose	No.	Item	Default	Settings	Remarks
<VF DISPLAY> Setting the basic status indications (page 47)	01 (U01)	FPS	ON	ON, OFF	
		ND	ON	ON, OFF	
		5600K	OFF	ON, OFF	
		WHITE	OFF	ON, OFF	
		GAIN	ON	ON, OFF	
		SHUTT	ON	ON, OFF	
		UNIT	deg	deg, sec	
		BATT12	ON	ON, OFF	
		BATT24	OFF	ON, OFF	
		REC	ON	ON, OFF	
		TAPE	OFF	ON, OFF	
		TC	OFF	ON, OFF	
MESSAG	ALL	ALL, AT, WRN, OFF		ALL: To display all messages AT: To display Auto Setup information and higher WRN: To display warning messages and higher OFF: To display warning messages of the highest level only	

OPERATION menu					
Page title & purpose	No.	Item	Default	Settings	Remarks
<'! IND> Setting the ABNORMAL <! > display	02 (U02)	ND	[IND] ON	ON, OFF	[IND]: Set whether to be included in the '!' indications on the ABNORMAL <! > display [NORMAL]: Specify the conditions under which the '!' indication is not to be displayed even if [IND] is ON. (By specifying the standard or normal conditions here, non-standard or abnormal conditions can be found with the '!' indication.) e.g.: With the default setting of ND, the '!' indication is displayed when an ND filter other than 1 is selected.
			[NORMAL] 1 - - - -	1, 2, 3, 4, 5 (combination allowed)	
		WHITE	[IND] ON	ON, OFF	
			[NORMAL] P - -	P, A, B (combination allowed)	
		5600K	[IND] ON	ON, OFF	
			[NORMAL] OFF	ON, OFF	
		SHUTT	[IND] ON	ON, OFF	
			[NORMAL] OFF	ON, OFF	
		FAN	[IND] ON	ON, OFF	
			[NORMAL] AUTO1	AUTO1, AUTO2, MIN, MAX	
		G-COMP	[IND] ON	ON, OFF	
				The normal condition is fixed to OFF.	
<CHAR/MARK MIX> Turning the character/marker ON/OFF and adjusting the brightness	03 (U09)	CHAR	VF1 ON	ON, OFF	Character superimposing ON/OFF
			VF2 ON	ON, OFF	
			MONI ON	ON, OFF	
			VBS OFF	ON, OFF	
		MARKER	VF1 ON	ON, OFF	Markers ON/OFF
			VF2 ON	ON, OFF	
			MONI ON	ON, OFF	
			VBS ON	ON, OFF	
		CURSOR	VF1 OFF	ON, OFF	Cursor ON/OFF
			VF2 OFF	ON, OFF	
			MONI OFF	ON, OFF	
		ZEBRA	VF1 OFF	ON, OFF	Zebra ON/OFF
			VF2 OFF	ON, OFF	
			MONI OFF	ON, OFF	
			VBS OFF	ON, OFF	
		CHAR/MARK LEVEL	50	0 to 50	Adjust the brightness of the character/marker indications.
		VF GATE MARKER	OFF	ON, OFF	For SKIN GATE and MULTI MATRIX GATE on the viewfinder

OPERATION menu					
Page title & purpose	No.	Item	Default	Settings	Remarks
<MARKER SETTING> Specifying markers	04 (U03)	CENTER	OFF	ON, OFF	
			1	1, 2, 3, 4	1: Entire cross 2: Entire cross with a hole 3: Center 4: Center with a hole
		SAFETY	OFF	ON, OFF	
			90.0%	80.0%, 90.0%, 92.5%, 95.0%	
		EFFECTIVE	OFF	ON, OFF	
		ASPECT	OFF	ON, OFF	
			4:3	2.40:1, 2.35:1, 1.85:1, 1.66:1, 16:9, 15:9, 14:9, 13:9, 4:3, VAR H, VAR V	1.66:1 : VISTA1 equivalent 1.85:1 : VISTA2 equivalent
		VARIABLE	1440	12 to 1920	
			1016	12 to 1080	
		SAFETY	OFF	ON, OFF	
			90.0%	80.0%, 90.0%, 92.5%, 95.0%	For the safety marker in Aspect mode
MASK	OFF	ON, OFF			
	12	0 to 15	Set the level to darken the areas outside the aspect marker.		
CURSOR	BOX	BOX, CROSS			
POSI H/V	0/0	-958 to 956/-538 to 536			
SIZE W/H	960/540	16 to 1920/16 to 1080			
<VF DETAIL> Adjusting the detail on the viewfinders	05 (U04)	VF1	ON	ON, OFF	
		VF2	ON	ON, OFF	
		LEVEL	25%	0 to 100%	
		CRISP	0	-99 to +99	
<ZEBRA> Setting the zebra	06 (U05)	VF1	OFF	ON, OFF	
		VF2	OFF	ON, OFF	
		MONITOR	OFF	ON, OFF	
		VBS	OFF	ON, OFF	
		ZEBRA TYPE	1	1, 2, 1&2	
		ZEBRA1 LEVEL	70%	0 to 109%	
		WIDTH	10%	0 to 30%	
		ZEBRA2	100%	50 to 109%	
<MONITOR OUTPUT> Setting the monitor output	07 (U06)	COLOR	COLOR	COLOR, R, G, B	
		OUTPUT			
		MONI HD-SDI	MONI	MONI, VF1, VF2	
		TEST OUT	VBS	VBS, VF2, REF-THRU, FRAME	
RM VIDEO	VBS	VBS, VF2			

OPERATION menu							
Page title & purpose	No.	Item	Default	Settings	Remarks		
<PB/MONI GAMMA> Setting the gamma of the playback picture/monitor picture	08 (U07)	MONI GAMMA ENABLE	OFF	ON, OFF			
		PB	VF OFF	OFF, ON, AUTO			
			MONI OFF	OFF, ON, AUTO			
			VBS OFF	OFF, ON, AUTO, (OFF)	(OFF): If either VF or MONI or both is/are R709 (cannot be changed)		
		PB MIX	VF OFF	OFF, ON,			
			MONI OFF	OFF, ON,			
			VBS OFF	OFF, ON, (OFF)	(OFF): If either VF or MONI or both is/are R709 (cannot be changed)		
		MONITOR GAMMA	VF OFF	OFF, R709, (OFF)	OFF: The same gamma as the main line R709: ITU-R709 (OFF): If MONI GAMMA ENABLE OFF (cannot be changed) (R709): If MONI GAMMA ENABLE ON (cannot be changed)		
			MONI OFF	OFF, R709, (OFF)			
			VBS OFF	OFF, (R709), (OFF)			
		GAMMA MARK SETTING				To jump to the subpage	
		<GAMMA MARK> subpage Setting for the monitor gamma mark		MONI GAMMA MARK	ON	ON, OFF	To turn the monitor gamma mark (709 γ) on or off
				MARK LEVEL	1	1, 2, 3, 4	To set the luminance of the gamma mark
H POSITION	0			0 to 99	To set the display position of the mark (0 for the leftmost or uppermost)		
V POSITION	0			0 to 99			
<PB MIX SETTING> Setting for mixing the playback picture	09 (U08)	MIX TYPE	MIX	MIX, WIPE			
		MIX					
		DIRECTION	CAM	CAM, PB			
		MODE	Y-MIX	Y-MIX, WIRE(W), WIRE(B)			
		LEVEL	80%	0 to 80%			
		WIPE					
		LAYOUT	HOR	HOR, VERT			
		PB POSITION	HOR: RIGHT VERT: BOTTOM	HOR: RIGHT, LEFT VERT: BOTTOM, TOP			
BOUNDARY	HOR: 960 VERT: 540	HOR: 0 to 1920 VERT: 0 to 1080					

OPERATION menu					
Page title & purpose	No.	Item	Default	Settings	Remarks
<SHUTTER ASSIGN> Setting the step shutter values	10 (U10)	STEP			[deg] column: Shutter angle value settings [sec] column: The converted speed values depending on the selected FPS value are displayed.
		1	216.0	360.0 to 4.3	
		2	180.0	360.0 to 4.3	
		3	172.8	360.0 to 4.3	
		4	150.0	360.0 to 4.3	
		5	144.0	360.0 to 4.3	
		6	90.0	360.0 to 4.3	
		7	45.0	360.0 to 4.3	
		8	22.5	360.0 to 4.3	
		ADD		Execute by ENTER.	To add a step shutter value
		DEL		Execute by ENTER.	To delete a step shutter value
PRESET		Execute by ENTER.	To resume the factory- set step shutter settings		
<SUBDISPLAY 1> Registering the formats to be selected on the assistant panel	11 (U11)	FORMAT MEMORY			Register the formats to be selected on the subdisplay. Select from among the formats displayed on the corresponding <FORMAT MEMORY> subpage.
		1	23.98P 444	NO ASSIGN, 23.98P 444, S23.98P 444, 29.97P 444, S29.97P 444, S59.94P 444, 23.98P 422, S23.98P 422, 29.97P 422, S29.97P 422, S59.94P 422, 24P 444, S24P 444, 25P 444, S25P 444, S30P 444, S50P 444, S60P 444, 24P 422, S24P 422, 25P 422, S25P 422, S30P 422, 50P 422, S50P 422, S60P 422, 50I 444, 50I 422, 59.94I 444, 59.94I 422	
		2	S23.97P 444	Same as above	
		3	S59.94P 422	Same as above	
		4	23.98P 422	Same as above	
		5	NO ASSIGN	Same as above	
		6	NO ASSIGN	Same as above	
		7	NO ASSIGN	Same as above	
		8	NO ASSIGN	Same as above	
<SUBDISPLAY 2> Setting the LOCK switch mode and subdisplay	12 (U12)	LOCK SW MODE			
		CAMERA	FULL	FULL, -RUN	Set the mode of the LOCK switch on the camera. -RUN: To enable the RUN button even when the LOCK switch is set to ON
		PANEL	FULL	FULL, -RUN	Set the mode of the LOCK switch on the assistant panel. -RUN: To enable the RUN button even when the LOCK switch is set to ON
		PAGE SELECT		Execute by ENTER.	To jump to the subpage

OPERATION menu					
Page title & purpose	No.	Item	Default	Settings	Remarks
<PAGE SELECT> subpage Selecting pages to be displayed on the subdisplay		SHUTTER	ON	ON, OFF	
		RAMP	ON	ON, OFF	
		FORMAT	ON	ON, OFF	
		ND	ON	ON, OFF	
		GAIN/WHITE/ 5600K	ON	ON, OFF	
		LENS FILE	ON	ON, OFF	
		TIME CODE/TAPE REM	ON	ON, OFF	
		VOLTAGE/FAN MODE	ON	ON, OFF	
		CHARACTER MIX	ON	ON, OFF	
		ASSIGNABLE SW1/SW2	ON	ON, OFF	
		ASSIGNABLE SW3/SW4	ON	ON, OFF	
		BRIGHT	ON	ON, OFF	
		GAMMA TABLE	ON	ON, OFF	
		COLOR SPACE	ON	ON, OFF	
	OPTICAL LEVEL	ON	ON, OFF		
<SWITCH ASSIGN> Setting the functions of the assignable buttons and switch	13 (U13)	ASSIGN SW1	OFF	OFF, ND, REC REVIEW, PB(VF), VF709GAM, MONI709GAM, FAN MODE, GAIN -9/-18 dB	Select from among the functions displayed on the corresponding subpage.
		ASSIGN SW2	OFF		
		ASSIGN SW3	OFF		
		ASSIGN SW4	OFF		
		RE - ROTATION	STD	STD, RVS	Specify operation mode of the MENU SEL/ENTER dial. STD: Clockwise rotation advances the pointer/ cursor or increases values on the menu screen. RVS: Counterclockwise rotation advances the pointer/cursor or increases values on the menu screen.
<GAIN ASSIGN> Specifying the gain switch settings	14 (U14)	GAIN	[L] 0 dB	-6, -3, 0, 3, 6, 9, 12 dB	Assign the values for the gain switch of the RM-B150.
			[M] 6 dB	-6, -3, 0, 3, 6, 9, 12 dB	
			[H] 12 dB	-6, -3, 0, 3, 6, 9, 12 dB	

OPERATION menu					
Page title & purpose	No.	Item	Default	Settings	Remarks
<BATTERY ALARM> Confirming the operating power voltage	15 (U15)	DC IN (24V)			
		TYPE	AC ADP	BATT1, BATT2, AC ADP	
		NEAR END	(22.2)		display only (Setting is achieved using the MAINTENANCE menu.)
		END	(21.6)		display only (Setting is achieved using the MAINTENANCE menu.)
		DC IN (12 V)			
		TYPE	AC ADP	BATT1, BATT2, AC ADP	
		NEAR END	(11.1)		display only (Setting is achieved using the MAINTENANCE menu.)
		END	(10.8)		display only (Setting is achieved using the MAINTENANCE menu.)
<OPERATOR FILE> Operating the Operator file	16 (U16)	READ (MS→CAM)		Execute by ENTER.	To read the operator file from a "Memory Stick"
		WRITE (CAM→MS)		Execute by ENTER.	To write the current settings of the operator file items to a "Memory Stick"
		PRESET		Execute by ENTER.	To set the operator file items to the preset values in internal memory
		FILE ID		alphanumerics (max.14 characters)	Enter a comment for the operator file to be written to a "Memory Stick." <i>See "Specifying a character string" (page 63).</i>
		CAM CODE		Camera code	display only
		DATE			display only
<LENS FILE> Operating the lens files	17 (U17)	FILE	1	1 to 32	
			No Offset	Lens file name	display only
		CENTER MARKER			To set and store the center marker position: H POS: Increasing the value moves it to the right. V POS: Increasing the value moves it downwards.
		H POS	0	-96 to 95	
		V POS	0	-54 to 53	
		STORE		Execute by ENTER.	Note This item is not displayed in Cine mode.
WHITE R/B	ON	ON, OFF	To turn the WHITE R/B compensation by the lens file on or off		

4-3-2 PAINT Menu

: Valid in Custom mode only (Switch settings, such as ON/OFF, are fixed to the default statuses in Cine mode.)
 : Valid in both Cine and Custom modes

Execute by ENTER. : Execute by pushing on the MENU SEL/ENTER dial.

Notes

- When the setting is in the fixed status, it is displayed in parentheses.
Example: (OFF)
- The markings [P01] to [P03] in the No. column indicate the page numbers in Cine mode.
The pages marked with [- -] in the No. column are not displayed in Cine mode.

PAINT menu					
Page title & purpose	No.	Item	Default	Settings	Remarks
<SW STATUS> Glancing and switching the paint functions on/off	P01 [P01]	FLARE	(OFF)	ON, OFF	Fixed to OFF in Cine mode
		GAMMA	(ON)	ON, OFF	Fixed to ON in Cine mode
		BLK GAM	(OFF)	ON, OFF	Fixed to OFF in Cine mode
		KNEE	(OFF)	ON, OFF	Fixed to OFF in Cine mode
		WHT CLIP	(OFF)	ON, OFF	Fixed to OFF in Cine mode
		DETAIL	(OFF)	ON, OFF	Fixed to OFF in Cine mode
		LVL DEP	(OFF)	ON, OFF	Fixed to OFF in Cine mode
		SKIN DTL	(OFF)	ON, OFF	Fixed to OFF in Cine mode
		MATRIX	(OFF)	ON, OFF	Fixed to OFF in Cine mode
		5600K	OFF	ON, OFF	
<VIDEO LEVEL> Adjusting the various video balance	P02 [- -]	WHITE	[R] [G] [B] [M] 0 0 0	-99 to +99	R, G, B, and M (master) values can be independently set. (M cannot be set for WHITE or FLARE.)
		BLACK	0 0 0 0	-99 to +99	
		FLARE	0 0 0	-99 to +99	
		GAMMA	0 0 0 0	-99 to +99	
		FLARE	OFF	ON, OFF	Fixed to OFF in Cine mode
		TEST	OFF	OFF, TEST1, TEST2	

PAINT menu					
Page title & purpose	No.	Item	Default	Settings	Remarks
<GAMMA> Adjusting the gamma	P03 [P02] (U18)	LEVEL	[R] [G] [B] [M] 0 0 0 0	-99 to +99	R, G, B, and M (master) values can be independently set.
		BLACK	0	-99 to +99	M (master) value only
		COARSE	0.45	0.35 to 0.90 (0.05 steps)	Fixed to 0.45 when HYPER GAMMA SPECIAL or USER is selected
		TABLE	USER	STANDARD, HYPER GAMMA, SPECIAL, USER	
			1	STANDARD 1: CAMCORDER 2: × 4.5 3: × 3.5 4: SMPTE-240M 5: ITU-R709 6: × 5.0 HYPER GAMMA 1: 325% to 100% 2: 460% to 100% 3: 325% to 109% 4: 460% to 109% SPECIAL 1: S-LOG A USER 1: S-LOG A 2: S-LOG A 3: S-LOG A 4: S-LOG A 5: S-LOG A	<i>For details, see "3-11 Selecting the Gamma" (page 56).</i>
		GAMMA	ON	ON, OFF	Fixed to ON in Cine mode
		KNEE	(OFF)	ON, OFF, (OFF)	(OFF): Fixed to OFF with the gamma setting other than STANDARD
		TEST	OFF	OFF, TEST1, TEST2	
<BLACK GAMMA> Adjusting the contrast near black	P04 [- -]	LEVEL	[R] [G] [B] [M] 0 0 0 0	-99 to +99	R, G, B, and M (master) values can be independently set.
		RANGE	HIGH	LOW, L.MID, H.MID, HIGH	
			OFF	ON, OFF	
		TEST	OFF	OFF, TEST1, TEST2	
<SATURATION> Adjusting the color saturation	P05 [- -]	SATURATION	0	-99 to +99	
			OFF	ON, OFF	
		LOW KEY SAT	0	-99 to +99	
		RANGE	HIGH	LOW, L.MID, H.MID, HIGH	
			OFF	ON, OFF	
		TEST	OFF	OFF, TEST1, TEST2	

PAINT menu					
Page title & purpose	No.	Item	Default	Settings	Remarks
<KNEE> Adjusting the compression for high-luminance areas	P06 [- -]	K POINT	[R] [G] [B] [M] 0 0 0 0	-99 to +99	R, G, B, and M (master) values can be independently set. K POINT: To adjust the point to apply the change K SLOPE: To adjust the slope of compression Absolute values are displayed in ABS mode except for M (master).
		K SLOPE	0 0 0 0	-99 to +99	
		KNEE	OFF	ON, OFF	
		KNEE MAX	OFF	ON, OFF	
		KNEE SAT	0	-99 to +99	To adjust the color saturation at high-luminance areas
			OFF	ON, OFF	
		AUTO KNEE	OFF	OFF, AUTO	
		POINT LIMIT	0	-99 to +99	Absolute value is displayed in ABS mode.
		SLOPE	0	-99 to +99	Absolute value is displayed in ABS mode.
ABS			Highlighted: ABS (Absolute) mode		
<WHITE CLIP> Adjusting the level to white-clip the high-luminance areas	P07 [- -]	W CLIP	[R] [G] [B] [M] 0 0 0 0	-99 to +99	R, G, B, and M (master) values can be independently set. Absolute values are displayed in ABS mode except for M (master).
			OFF	ON, OFF	
		ABS			Highlighted: ABS (Absolute) mode
<DETAIL 1> Adjusting the emphasis of the contours in video	P08 [- -]	DETAIL	OFF	ON, OFF	Fixed to OFF in Cine mode
		LEVEL	0	-99 to +99	Absolute value is displayed in ABS mode.
		LIMITER	[M] 0	-99 to +99	To adjust the level to clip the maximum value of the emphasis signal Absolute values are displayed in ABS mode except for M (master).
			[WHT] 0	-99 to +99	
			[BLK] 0	-99 to +99	
		CRISP	0	-99 to +99	To adjust the level for noise suppression (Absolute values are displayed in ABS mode)
		LVL DEP	0	-99 to +99	To adjust the emphasis elements suppressed by gamma (Absolute values are displayed in ABS mode.)
			OFF	ON, OFF	
ABS			Highlighted: ABS (Absolute) mode		

PAINT menu					
Page title & purpose	No.	Item	Default	Settings	Remarks
<DETAIL 2> Adjusting the emphasis of the contours in video	P09 [- -]	H/V RATIO	0	-99 to +99	To specify the vertical factor of the contour emphasis (Absolute values are displayed in ABS mode.)
		FREQ	0	-99 to +99	To adjust the video frequency components to be emphasized (Absolute values are displayed in ABS mode.)
		MIX RATIO	0	-99 to +99	Absolute value is displayed in ABS mode.
		KNEE APT	0	-99 to +99	For contour emphasis in high-luminance areas compressed by the KNEE function (Absolute values are displayed in ABS mode.)
			OFF	ON, OFF	
		ABS			Highlighted: ABS (Absolute) mode
<SKIN DETAIL> Emphasizing the contours of the specific color components	P10 [- -]	SKIN DTL	OFF	ON, OFF	Fixed to OFF in Cine mode
		SKIN GATE	OFF	OFF, 1, 2, 3	1, 2, 3: Skin gate can be set to ON for the specified channel only. With the ON setting, a zebra pattern is displayed for the color component affected by the DETAIL function.
		ABS			Highlighted: ABS (Absolute) mode
		CH SW	[1] [2] [3] (ON) OFF OFF	ON, OFF	The skin tone detail function can be independently set for each channel (channel 1 is always ON).
		HUE	EXEC EXEC EXEC	Execute by ENTER.	
		PHASE	0 0 0	0 to 359	HUE: For automatic detection of the target color
		WIDTH	29 29 29	0 to 90	
		SAT	-89 -89 -89	-99 to +99	
		LEVEL	0 0 0	-99 to +99	Absolute values are indicated for LEVEL only in ABS mode.

PAINT menu					
Page title & purpose	No.	Item	Default	Settings	Remarks
<USER MATRIX> Adjusting the color components without affecting the black and white components	P11 [- -]	R-G	0	-99 to +99	
		R-B	0	-99 to +99	
		G-R	0	-99 to +99	
		G-B	0	-99 to +99	
		B-R	0	-99 to +99	
		B-G	0	-99 to +99	
		MATRIX	OFF	ON, OFF	
		PRESET	- -	ON, OFF, (OFF), - -	Invalid when MATRIX is OFF (- - indication) (OFF): Fixed to OFF when MATRIX is ON with COLOR SPACE set to S-GAMUT or DCDM REF PJ
			- -	SMPTE-240M, ITU-709, SMPTE-WIDE, NTSC, EBU, - -	Invalid when MATRIX is OFF (- - indication)
		USER	- -	ON, OFF, - -	Invalid when MATRIX is OFF (- - indication)
MULTI	- -	ON, OFF, - -	Invalid when MATRIX is OFF (- - indication)		
<MULTI MATRIX> Adjusting the color components independently by dividing into 16 axes	P12 [- -]	PHASE	0	0, 23, 45, 68, 90, 113, 135, 158, 180, 203, 225, 248, 270, 293, 315, 338	Select an axis (angle) at PHASE for which the multimatrix adjustment is to be made, and set HUE and SAT. (HUE and SAT can be adjusted independently for 16 axes.)
				B, B+, MG-, MG, MG+, R, R+, YL-, YL, YL+, G-, G, G+, CY, CY+, B-	
		HUE	0	-99 to +99	
		SAT	0	-99 to +99	
		ALL CLEAR		Execute by ENTER.	
		GATE	OFF	ON, OFF	
		MATRIX	OFF	ON, OFF	
		PRESET	- -	ON, OFF, (OFF), - -	Invalid when MATRIX is OFF (- - indication) (OFF): Fixed to OFF when MATRIX is ON with COLOR SPACE set to S-GAMUT or DCDM REF PJ
			- -	SMPTE-240M, ITU-709, SMPTE-WIDE, NTSC, EBU, - -	Invalid when MATRIX is OFF (- - indication)
		USER	- -	ON, OFF, - -	Invalid when MATRIX is OFF (- - indication)
MULTI	- -	ON, OFF, - -	Invalid when MATRIX is OFF (- - indication)		

PAINT menu						
Page title & purpose	No.	Item	Default	Settings	Remarks	
<SHUTTER/FPS> Adjusting the shutter while observing the shutter angles and speeds	P13 [P03] (U19)	SHUTTER	OFF	ON, OFF	Setting to ON displays the current shutter values in the [deg] and [sec] columns. [deg]: Shutter angle (360.0 to 4.3) [sec]: Shutter speed obtained according to the angle in [deg] and the FRAME RATE value	
		STEP			To change the shutter value in Step mode	
		CONTINUOUS			To change the shutter value in Continuous mode	
		STEP ASSIGN				
		ADD			Execute by ENTER.	To add a step shutter value
		DELETE			Execute by ENTER.	To delete a step shutter value
		FRAME RATE	--		For S23.98PsF/S24PsF: 1 to 24 For S25PsF: 1 to 25 For S29.97PsF/S30PsF: 1 to 30 For S50P/S59.94P/S60P: 1 to 50	When the video format is fixed, the value is indicated in parentheses. The selectable values depend on the format and gain compensation mode. <i>For details, see "3-9 Detailed Shutter Settings" (page 54).</i>
		COMP MODE	OFF		OFF, ANGLE, GAIN	To select Compensation mode
<RAMP> Setting and executing the RAMP functions	P14 [P04]	CURRENT			The current FPS value is displayed.	
		START	24 FPS	Same as those of FRAME RATE of <SHUTTER/FPS>.	To set the start FPS value	
		END	24 FPS	Same as those of FRAME RATE of <SHUTTER/FPS>.	To set the end FPS value	
		DURATION	30s	0 to 30s	To set the transition time.	
		COMP MODE	OFF	OFF, ANGLE, GAIN	To select shutter compensation mode	
		RAMP MODE	OFF	OFF, LINEAR, EXPONENTIAL	To select the RAMP mode	
		DIR		Execute by ENTER.	To inverse the START and END values of FPS	
		RAMP		Execute by ENTER.	To start the RAMP operation (invalid when RAMP MODE is OFF)	
<NOISE SUPPRESS> Setting the noise suppression function	P15 [- -]	NOISE SUP	OFF	ON, OFF	<i>See "Noise Suppression" (page 77).</i>	
		LEVEL	LOW (30%)	LOW (30%), MID (60%), HIGH (90%), MAX (100%)		

PAINT menu						
Page title & purpose	No.	Item	Default	Settings	Remarks	
<SCENE FILE> Storing and retrieving scene files (data set by the PAINT menu)	P16 [- -]	1			When storing a file in camera memory, specify the number before executing STORE. When reading, only specify the number.	
		2				
		3				
		4				
		5				
			01		01 to 32	To specify the scene file number 01 to 32 when 32 SCENE FILE of <OTHERS 2> of the MAINTENANCE menu is ON.
			STORE		Execute by ENTER.	
			STANDARD		Execute by ENTER.	To read the standard paint data
			READ (MS→CAM)		Execute by ENTER.	To load scene files from a "Memory Stick" to internal memory
			WRITE (CAM→MS)		Execute by ENTER.	To write scene files in the camera's memory to a "Memory Stick"
			FILE ID		Max.14 characters	Enter a comment for the scene files to be written to a "Memory Stick."
		CAM CODE		Camera code	display only (When files made on are detected, "F35" is displayed.)	
		DATE		Date of file creation	display only	

Noise Suppression

This function you can enable on the PAINT menu <NOISE SUPPRESS> page effectively suppresses noise components while maintaining fine edge components of a subject.

As the noise suppression function of this camera employs a system to extract and depress noise within a frame, it also shows strong characteristics for movement of a subject compared with noise reduction that uses frame correlation. You can select from among 4 effect levels; LOW (30%), MID (60%), HIGH (90%), MAX (100%).

LOW: To mainly cut noise components in the high range

MID: To mainly cut noise components in the high and middle ranges

HIGH: To mainly cut noise components in the high, middle, and low ranges

MAX: To mainly cut noise components in the high, middle, and low ranges

The % values are references of the effect when assuming the maximum is 100%.

Note

This function somewhat affects frequency components of actual images, and the contours of low-luminance blocks may be weakened. A preliminary test shooting is recommended to check in advance.

4-3-3 MAINTENANCE Menu

: Valid in Custom mode only
 : Valid in both Cine and Custom modes

Execute by ENTER. : Execute by pushing on the MENU SEL/ENTER dial.

Note

The markings [M01] to [M11] in the No. column indicate the page numbers in Cine mode.
 The pages marked with [- -] in the No. column are not displayed in Cine mode.

MAINTENANCE menu					
Page title & purpose	No.	Item	Default	Settings	Remarks
<BASE SETTING> Setting the basic operation mode	M01 [M01]	SHOOT MODE	CINE	CINE, CUSTOM	
		D-RANGE	EXTEND	EXTEND, NORMAL	EXTEND: To improve the dynamic range and sensitivity Fixed to EXTEND in Cine mode
		COLOR SPACE	S-GAMUT	S-GAMUT, F900, F900R, DCDM REF PJ	S-GAMUT: Wide color space designed for this camera F900: Color space equivalent to other HD cameras F900R: Color space equivalent to HDW-F900R (only with <OTHERS 2> COLOR F900R ENABLED DCDM REF PJ: Color space of the reference projector specified by DC
<AUTO SETUP> Various auto balance adjustments	M02 [- -]	AUTO BLACK		Execute by ENTER.	
		AUTO WHITE		Execute by ENTER.	
		AUTO LEVEL		Execute by ENTER.	
		AUTO WHITE SHADING		Execute by ENTER.	Do not execute if a flat white subject is not available.
		AUTO BLACK SHADING		Execute by ENTER.	
		TEST	OFF	OFF, TEST1, TEST2	

MAINTENANCE menu						
Page title & purpose	No.	Item	Default	Settings	Remarks	
<WHITE SHADING> Adjusting the shading of white level	M03 [- -]	V SAW	[R] [G] [B] 0 0 0	-99 to +99	R, G, and B values can be independently set. V SAW, H SAW: To vertically or horizontally adjust the slope of shading compensation V PARA, H PARA: To vertically or horizontally adjust the irregularity of shading compensation	
		V PARA	0 0 0	-99 to +99		
		H SAW	0 0 0	-99 to +99		
		H PARA	0 0 0	-99 to +99		
		WHITE	0 0 0	-99 to +99		
		AUTO WHITE SHADING			Execute by ENTER.	
		WHITE SHAD MODE	RB		RGB, RB	RGB: To adjust the shading independently for R, G, and B RB: To adjust R and B according to G
<BLACK SHADING> Adjusting the shading of black level	M04 [- -]	V SAW	[R] [G] [B] [M] 0 0 0	-99 to +99	R, G, and B values can be independently set. M (master) value can also be set for BLACK. V SAW, H SAW: To vertically or horizontally adjust the slope of shading compensation V PARA, H PARA: To vertically or horizontally adjust the irregularity of shading compensation	
		V PARA	0 0 0	-99 to +99		
		H SAW	0 0 0	-99 to +99		
		H PARA	0 0 0	-99 to +99		
		BLK SET	0 0 0	-99 to +99		
		BLACK	0 0 0 0	-99 to +99		
		MASTER GAIN	0 dB			-6, -3, 0, 3, 6, 9, 12 dB
		AUTO BLACK SHADING			Execute by ENTER.	
<OHB MATRIX> Adjusting the colors at the CCD block (OHB) to match the colors among multiple cameras (can be stored in the OHB file)	M05 [- -]	PHASE	0	0, 23, 45, 68, 90, 113, 135, 158, 180, 203, 225, 248, 270, 293, 315, 338	To select an axis (angle) at PHASE for which the OHB matrix adjustment is to be made, and set HUE and SAT (HUE and SAT can be adjusted independently for 16 axes).	
		HUE	0	-99 to +99		
		SAT	0	-99 to +99		
		ALL CLEAR			Execute by ENTER.	To clear the HUE and SAT values for all PHASE settings
		OHB MATRIX	ON		ON, OFF	Always ON in Cine mode
		MATRIX	OFF		ON, OFF	Always OFF in Cine mode
<AUDIO> Selecting the SDI channels to which the microphone inputs are added	M06 [M02]	CAMERA MIC CH SELECT IF BOX	CH5/6	CH1/2, CH5,6		

MAINTENANCE menu					
Page title & purpose	No.	Item	Default	Settings	Remarks
<OUTPUT FORMAT> Setting the output video format	M07 [M03]	CURRENT	23.98PsF 4:4:4		The current format is displayed.
		SCAN	PROGRESSIVE	PROGRESSIVE, INTERLACE	When INTERLACE is selected for SCAN, select half the value of the field frequency in FRAME.
		FRAME	23.98	23.98, 24, 25, 29.97, 30, 50, 59.94, 60	
		SIGNAL	4:4:4 RGB	4:4:4 RGB, 4:2:2 YCbCr	
		SELECT FPS	OFF	ON, OFF	
		SET FORMAT		Execute by ENTER.	
<DOWN CONVERTER> Setting the aspect ratio for VBS output	M08 [M04]	ASPECT	LB	SQ, LB, EC	SQ: Squeeze LB: Letter Box EC: Edge Crop
<POWER SAVE> Selecting the output power save mode	M09 [M05]	MONITOR OUT	ACTIVE	PWR SAVE, ACTIVE	
		DOWN CONVERTER	ACTIVE	PWR SAVE, ACTIVE	
<BATT ALARM SET> Setting the voltage values to trigger alarm indications	M10 [M06]	DC IN (24 V)			
		TYPE	AC ADP	BATT1, BATT2, AC ADP	BATT1/BATT2: Batteries AC ADP: AC adaptor
		NEAR END	22.2 V	0.1 to 30.0 V	Fixed to the default value for AC ADP
		END	21.6 V	0 to 29.9 V	Fixed to the default value for AC ADP
		DC IN (12 V)			
		TYPE	AC ADP	BATT1, BATT2, AC ADP	BATT1/BATT2: Batteries AC ADP: AC adaptor
		NEAR END	11.1 V	11.0 to 17.0 V	Fixed to the default value for AC ADP
		END	10.8 V	10.5 to 14.0 V	Fixed to the default value for AC ADP
<GENLOCK> Adjusting Genlock with status indications	M11 [M07]	REFERENCE		INTERNAL, GENLOCK IN	display only
		STATUS		OK, NG, NO SIGNAL	display only
		H PHASE	0	-511 to 511	To adjust the H phase for genlock (With a CA-F101 mounted, “--” is displayed and the setting cannot be changed.)
<DATE> Setting the built-in clock	M12 [M08]	DATE/TIME		yyyy/mm/dd hh : mm	

MAINTENANCE menu					
Page title & purpose	No.	Item	Default	Settings	Remarks
<METADATA> Recording/ reproducing metadata	M13 [M09]	EMBEDDED	OFF	ON, OFF	To turn the function to embed metadata on tapes and SDI signals on or off
		ANC LINE	9	(9)	SDI V ANC LINE number (currently fixed to 9)
		TYPE	USER1	(USER1)	Format of items in metadata (currently fixed to USER 1)
		REC MS WRITE	OFF	ON, OFF	To turn the function to simultaneously write metadata to a "Memory Stick" while embedding them to SDI output in recording on or off
		PLAY MS WRITE	OFF	ON, OFF	To turn the function to read embedded metadata and write them to a "Memory Stick" in playback on or off

MAINTENANCE menu					
Page title & purpose	No.	Item	Default	Settings	Remarks
<OTHERS 1> Setting various subsidiary functions	M14 [M10] (U20)	FAN MODE	AUTO1	AUTO1, AUTO2, MIN, MAX	To select the operation modes of the fans AUTO1: Automatically controlled according to the internal temperature and in a quiet condition during recording AUTO2: Normally controlled in MIN mode and in a quieter condition during recording (only for a short recording under ordinary ambient temperature) MIN: The quietest fan operation is maintained without synchronization with recording (only for use under ordinary ambient temperature). MAX: The fans rotate at the maximum speed.
		CAM BARS	OFF	ON, OFF	To turn the built-in color generator on or off
		HD-BAR (VF/MONI)	BAR 16:9 (100%)	BAR 16:9 (100%), BAR 16:9 (75%), SMPTE 16:9 (BLACK), SMPTE 16:9 (-I/Q), BAR 4:3 (100%), BAR 4:3 (75%), SMPTE 4:3 (BLACK), SMPTE 4:3 (-I/Q), MF-ARIB (75%), MF-ARIB (100%), MF-ARIB (+I), MF-SMPTE (-I, Q), MF-SMPTE (75%, Q), MF-SMPTE (100%, Q), MF-SMPTE (+I, Q), HD-CUSTOM, HD-CUSTOM2	To select the color bar format for HD outputs
		SD-BAR	SMPTE	SMPTE, EIA, FULL (EBU), 95%, NTSC100% (PAL100%)	To select the color bar format for SD outputs EBU, PAL100%: With 1.000 formats
		IMAGE INVERT	OFF	ON, OFF	To turn the image-inversion function on or off (ON to set the camera picture upside-down)
		IRIS CLOSE	OFF	ON, OFF	
		MONI REMOTE REC	OFF	ON, OFF	To turn the function to feed a REC trigger signal to a recorder connected to the MONITOR OUT HD SDI connectors 1 and 2, enabling synchronized recording with SRW-1. Applicable recorders: HDW-250, HDW-S280

MAINTENANCE menu					
Page title & purpose	No.	Item	Default	Settings	Remarks
<OTHERS 2> Setting various subsidiary functions	M15 [M11]	DATE TYPE	5 M/D/Y	1 Y/Mn/D 2 Mn/D 3 D/M/Y 4 D/M 5 M/D/Y 6 M/D	To select the date display mode Y: Year Mn: Month (numeric) M: Month (character string) D: Day
		V DTL CREATION ¹⁾	Y	NAM, G, R+G, Y	To specify from which signal the vertical detail volume is to be created NAM: The highest signal among R, G, and B G: G signal R+G: Additional value of the R signal and G signal Y: Y signal
		DTL H/V MODE ¹⁾	H/V	H/V, V ONLY	H/V: To change the H detail at the same time when adjusting the V detail V ONLY: To adjust V detail while maintaining the H detail
		TEST2 MODE	20% STEP	20% STEP, 10STEP	20% STEP: 20%-steps up to full scale when gamma is OFF 10STEP: 10%-steps up to 100% when gamma is OFF
		WHITE SETUP MODE ¹⁾	A.LVL	AWB, A.LVL	A.LVL: To return the white value to "0" when STANDARD is executed AWB: To return the white value to the AWB value when STANDARD is executed
		FPS LIMITER	LIMIT	LIMIT, FREE	LIMIT: To limit the variable range of the FPS setting FREE: To release the range limitation of the FPS setting
		EXT I/O MODE	ARRI RMT	ARRI RMT, LSI, TERMINAL	To select EXT I/O mode ARRI RMT: When an ARRI Remote Control is connected LSI: When a jig application is connected (for adjustments) TERMINAL: When a terminal is connected (for adjustments)
		COLOR F900R	ENABLE	ENABLE, DISABLE	To enable/disable selection of F900R COLOR SPACE mode
		32 SCENE FILE	OFF (5)	ON, OFF (5)	To turn the function to expand the number of scene files to be registered to 32 on or off

1) Not displayed in Cine mode

4-3-4 NETWORK Menu

The NETWORK menu items can be set in both Cine and Custom modes.

For details, see “Parameter Settings” (page 104).

Execute by ENTER. Execute by pushing on the MENU SEL/ENTER dial.

NETWORK menu						
Page title	No.	Item	Default	Settings	Remarks	
<IP ADDR SET>	N01	HOST IP ADDRESS	0.0.0.0	0.0.0.0 to 255.255.255.255		
		SUBNET MASK	255.255.255.0	0.0.0.0 to 255.255.255.255		
		DEFAULT GATEWAY	0.0.0.0	0.0.0.0 to 255.255.255.255		
		SET		Execute by ENTER.	Power must be turned off then on again to activate the execution.	
<ETHER I/F CONF>	N02	AUTO NEGOTIATION	ON			
		CONNECT CONFIGURATION				
		CONNECT SPEED	100M	10M, 100M		
		DUPLEX MODE	FULL	HALF, FULL		
		SET		Execute by ENTER.	Power must be turned off then on again to activate the execution.	
<700PTP SETTING>	N03	NS MODE	LEGACY	LEGACY, BRIDGE, MCS		
		MCS MODE	(CLIENT)		fixed	
		CAMERA NO.	0	0 to 24	Select a number other than 0 when connected.	
		MASTER IP ADDRESS	0.0.0.0	0.0.0.0 to 255.255.255.255		
		SET		Execute by ENTER.		
<NETWORK RESET>	N04	ALL RESET		Execute by ENTER.	To initialize all the NETWORK menu settings	

4-3-5 FILE Menu

For details on the files, see “Chapter 5 Storage and Retrieval of User Setting Data”.

: Valid in Custom mode only

: Valid in both Cine and Custom modes

Execute by ENTER. : Execute by pushing on the MENU SEL/ENTER dial.

Note

The markings [F01] to [F04] in the No. column indicate the page numbers in Cine mode.

The pages marked with [- -] in the No. column are not displayed in Cine mode.

FILE menu					
Page title	No.	Item	Default	Settings	Remarks
<OPERATOR FILE>	F01 [F01]	READ (MS→CAM)		Execute by ENTER.	To read the operator file from a “Memory Stick”
		WRITE (CAM→MS)		Execute by ENTER.	To write the current settings of the operator file items to a “Memory Stick”
		PRESET		Execute by ENTER.	To set the operator file items to the preset values in internal memory
		FILE ID		max.14 characters	Enter a comment for the operator file to be written to a “Memory Stick.” <i>See “Specifying a character string” (page 63).</i>
		CAM CODE	F35	Camera code	display only
		DATE			display only

FILE menu						
Page title	No.	Item	Default	Settings	Remarks	
<SCENE FILE>	F02 [- -]	1			To store and load scene files (paint data): When storing a file in the camera's memory, specify the number before executing STORE. When reading, only specify the number.	
		2				
		3				
		4				
		5				
				01	01 to 32	To specify the scene file number 01 to 32 when 32 SCENE FILE of <OTHERS 2> of the MAINTENANCE menu is ON.
			STORE		Execute by ENTER.	
			STANDARD		Execute by ENTER.	To read the standard paint data stored in the reference file
			READ (MS→CAM)		Execute by ENTER.	To load scene files from a "Memory Stick" to the camera's memory
			WRITE (CAM→MS)		Execute by ENTER.	To write scene files in the camera's memory to a "Memory Stick"
			FILE ID		Max. 14 characters	Enter a comment for the scene files to be written to a "Memory Stick." See "Specifying a character string" (page 63).
		CAM CODE	F35	Camera code	display only	
		DATE			display only	
<REFERENCE>	F03 [- -]	STORE FILE		Execute by ENTER.	To store the current settings of the reference file items in the reference file in the camera's memory	
		STANDARD		Execute by ENTER.	To read the standard values in the reference file in the camera's memory	
		READ (MS→CAM)		Execute by ENTER.	To load a reference file from a "Memory Stick"	
		WRITE (CAM→MS)		Execute by ENTER.	To write the current settings of the reference file items as a reference file to a "Memory Stick"	
		FILE ID		Max. 14 characters	Enter a comment for the reference file to be written to a "Memory Stick." See "Specifying a character string" (page 63).	
		CAM CODE	F35	Camera code	display only	
		DATE			display only	
<USER GAMMA>	F04 [F02]	READ (MS→CAM)		Execute by ENTER.	To load user gamma tables from a "Memory Stick"	
		FILE ID		Max. 14 characters	display only	
		CAM CODE	F35	Camera code	display only	
		DATE			display only	

FILE menu					
Page title	No.	Item	Default	Settings	Remarks
<LENS FILE>	F05 [F03]	STORE FILE ¹⁾		Execute by ENTER.	
		No.	1	1 to 32	
		NAME	No Offset		
		CENTER ¹⁾			To set and store the center marker position: H: Increasing the value moves it to the right. V: Increasing the value moves it downwards.
		H ¹⁾	0	-96 to 95	
		V ¹⁾	0	-54 to 53	
		STORE ¹⁾		Execute by ENTER.	
		WHITE R/B	ON	ON, OFF	To turn the WHITE R/B compensation by the lens file ON/OFF
LENS MS READ/ WRITE		Execute by ENTER.	To jump to the subpage		
<LENS FILE> subpage		READ (MS→CAM)		Execute by ENTER.	To load a lens file from a "Memory Stick" (max. 32 files)
		WRITE (CAM→MS)		Execute by ENTER.	To write the current settings of the lens file items as a lens file to a "Memory Stick"
		FILE ID		Max.14 characters	Enter a comment for the lens file to be written to a "Memory Stick." <i>See "Specifying a character string" (page 63).</i>
		CAM CODE	F35	Camera code	display only
		DATE			display only
<OHB FILE>	F06 [- -]	STORE FILE		Execute by ENTER.	To store the offset values of the items specific to the CCD (No repeated store operation is necessary even if the CCD is reattached.)

FILE menu					
Page title	No.	Item	Default	Settings	Remarks
<FILE PRESET>	F07 [F04]	OPERATOR FILE		Execute by ENTER.	To resume the factory-set status
		USER GAMMA FILE		Execute by ENTER.	To resume the factory-set status
		LENS FILE (ALL) ¹⁾		Execute by ENTER.	To resume the factory-set status for all lens files
		No. ¹⁾		1 to 32	To resume the factory-set status for a selected lens file
		CLEAR ¹⁾		Execute by ENTER.	
		REFERENCE FILE ¹⁾		Execute by ENTER.	To resume the factory-set status
		10 SEC CLEAR ¹⁾	OFF	ON, OFF	ON: To return a specific item in the reference file to the factory-set value. <i>For details, see "5-3-8 Resetting to the Initial Settings" (page 101).</i>
		OHB FILE ¹⁾		Execute by ENTER.	To jump to the <OHB FILE> subpage
		USER MENU		Execute by ENTER.	To resume the factory-set status
		M. S. FORMAT		Execute by ENTER.	To initialize a "Memory Stick"
		FILE PRESET (-OHB) ¹⁾			To return all files except the OHB file to their factory-set statuses
<OHB FILE> (<FILE PRESET> subpage)	[- -]	OHB WHITE SHADE (ALL)		Execute by ENTER.	To return all the WHITE SHADING data in the OHB file to their factory-set statuses.
		3D WHITE SHADING		Execute by ENTER.	To return only the 3D WHITE SHADING setting to its factory-set status
		BLACK SHADING		Execute by ENTER.	To return only the BLACK SHADING setting to its factory-set status
		BLACK SET		Execute by ENTER.	To return only the BLACK SET setting to its factory-set status
		ND OFFSET		Execute by ENTER.	To return only the ND OFFSET setting to its factory-set status
		MATRIX		Execute by ENTER.	To return only the MATRIX setting to its factory-set status

1) Not displayed in Cine mode

4-3-6 DIAGNOSIS Menu

This menu is only for viewing and no setting is made using this menu.

Page title	No.	Item	Indication	Remarks
<BOARD STATUS>	D01	OHB	OK, NG	display only (If NG is displayed, consult your local Sony representative.)
		AD	OK, NG	
		DPR	OK, NG	
		VDA	OK, NG	
		TR	OK, NG	
		AT	OK, NG	
<SYSTEM STATUS>	D02	DOCKING STATUS		Indicates the device docked on the top or rear of the camera. ---: No device IF BOX: Interface box supplied with the camera VTR: SRW-1 video recorder OPT CA: CA-F101 (Changes to "OPT CA - VTR" when the CA-F101 and the SRPC-1 is connected via a hybrid optical camera cable.) (IF BOX), (OPT CA): Indicated in parentheses if combination use of the docked device is not allowed.
		TOP	---, IF BOX, VTR, OPT CA, (IF BOX), (OPT CA)	
		REAR	---, IF BOX, VTR, OPT CA, (IF BOX), (OPT CA)	
	OPTICAL STATUS		Indicates the optical reception status on the camera side (VTR→CAM) and that on the recorder side (CAM→VTR) while signal transmission is in progress. OK: Normal CARE: Cautioning level WARNING: Warning level NG: Unusable level NO SIGNAL: No signal	
	VTR→CAM	OK, CARE, WARNING, NG, NO SIGNAL		
	CAM→VTR	OK, CARE, WARNING, NG, NO SIGNAL		
<PLD VERSION>	D03	TG	Vx.xxx	display only
		AD	Vx.xxx	display only
		PRE	Vx.xxx	display only
		POST	Vx.xxx	display only
		TX	Vx.xxx	display only
		RX	Vx.xxx	display only
		VDA	Vx.xxx	display only
		AT	Vx.xxx	display only
<ROM VERSION>	D04	MAIN	Vx.xx, M/D/Y	display only
		NET	Vx.xx, M/D/Y	display only
		BOOT	Vx.xx, M/D/Y	display only

4-4 Editing the USER Menu

You can select desired pages and items from the OPERATION, PAINT, MAINTENANCE, NETWORK, FILE, and DIAGNOSIS menus and register them to the USER menu. If you specify pages or items frequently used for the USER menu, you can easily call and use them.

The USER MENU CUSTOMIZE menu allows you to configure a USER menu that consists only of pages and items that you need, by your adding, deleting or replacing pages.

Creating a new page

The USER MENU CUSTOMIZE menu allows you to add a new page to the USER menu.

While the EDIT page contains factory-preset items, the USER 1 EDIT to USER 19 EDIT pages are all blank in their initial state. You can register up to 10 items, including blank lines, on each of these pages.

To create a new page, proceed as follows.

- 1 While holding the CANCEL/STATUS button pressed, press the VF MENU/DISPLAY button.

The TOP MENU screen appears.

- 2 Turn the MENU SEL/ENTER dial to move the pointer to “USER MENU CUSTOMIZE,” then push on the MENU SEL/ENTER dial.

If this is the first time the USER MENU CUSTOMIZE menu has been displayed, the CONTENTS page of the menu appears.

```

CONTENTS      E00 TOP
↓ ↓
01 .EDIT PAGE
02 .USER 1 EDIT
→03 .USER 2 EDIT
04 .USER 3 EDIT
05 .USER 4 EDIT
06 .USER 5 EDIT
07 .USER 6 EDIT
08 .USER 7 EDIT
09 .USER 8 EDIT
10 .USER 9 EDIT
  
```

If the USER MENU CUSTOMIZE menu has been used before, the page last accessed appears.

- 3 If the CONTENTS page is displayed, turn the MENU SEL/ENTER dial to move the pointer to any of USER 1 EDIT to USER 19 EDIT then push on the MENU SEL/ENTER dial to display the page.

If a different page is displayed, turn the MENU SEL/ENTER dial until the desired page appears, then push on the MENU SEL/ENTER dial to select the page.

Example: When you select the USER 2 EDIT page

```

USER 2 EDIT  E03 TOP
→
  
```

- 4 Move the pointer to the item to be added (this operation is unnecessary if no item exists on the page, as shown in the figure for step 3) then push on the MENU SEL/ENTER dial.

The EDIT FUNCTION screen appears.

```

EDIT FUNCTION  ESC
→ INSERT
  MOVE
  DELETE
  BLANK
  
```

- 5 Move the pointer to “INSERT” and push on the MENU SEL/ENTER dial.

The page with the last item added appears.

```

<Sw STATUS>      P22 ESC
FLARE      : → ON
GAMMA      :  ON
BLK GAM    :  OFF
KNEE       :  ON
WHT CLIP   :  ON
DETAIL     :  ON
LVL DEP    :  ON
SKIN DTL   :  OFF
MATRIX     :  OFF
5600K      :  OFF
  
```

- 6 Add the items.
 - ① Turn the MENU SEL/ENTER dial until the page that has the desired items appears, then push on the MENU SEL/ENTER dial.
 - ② Turn the MENU SEL/ENTER dial to move the pointer to the desired item, then push on the MENU SEL/ENTER dial.

The USER 2 EDIT page appears again, displaying the newly added item.

7 Add the remaining items by repeating steps 4 to 6.

You can add up to 10 items on one page.

To delete items from a page

Proceed as follows:

- 1 Move the pointer to the item to be deleted, and push on the MENU SEL/ENTER dial.

The EDIT FUNCTION screen appears.

- 2 Select “DELETE,” and push on the MENU SEL/ENTER dial.

The previously displayed page appears again, and the message “DELETE OK? Yes →No” appears at the upper right.

- 3 To delete, turn the MENU SEL/ENTER dial to move the pointer to “YES,” and push on the MENU SEL/ENTER dial.

To change the order of items on a page

Proceed as follows:

- 1 Turn the MENU SEL/ENTER dial to move the pointer to the item to be moved, then push on the MENU SEL/ENTER dial.

The EDIT FUNCTION screen appears.

- 2 Select MOVE, then push on the MENU SEL/ENTER dial.

The previously displayed page appears again.

- 3 Turn the MENU SEL/ENTER dial to move the pointer to the position where you wish to move the item, then push on the MENU SEL/ENTER dial.

ITEM	MOVE	ESC
↓ ↓		
→VF	OUT	: COLOR
	VF	DETAIL : OFF
	MARKER	: ON
	CURSOR	: OFF
	ZEBRA SW	: OFF
		: 1
•AS1		: OFF

The item selected in step 1 moves to the position that you selected in step 3.

In the above example, “AS1” is moved to the top and the other items are moved down one line.

To insert a blank line

Proceed as follows:

- 1 Turn the MENU SEL/ENTER dial to move the pointer to the item above which you wish to insert a blank line.

The EDIT FUNCTION screen appears.

- 2 Select “BLANK” then push on the MENU SEL/ENTER dial.

The previously displayed page appears again, and a blank line is inserted above the specified item.

Note

You cannot insert a blank line on a page where 10 items have already been registered.

Adding/deleting/replacing pages

You can add a new page to the USER menu, delete a page from the USER menu or replace pages, using the EDIT PAGE of the USER MENU CUSTOMIZE menu.

To add a page

Proceed as follows:

- 1 Select “USER MENU CUSTOMIZE” on the TOP MENU screen.

If this is the first time the USER MENU CUSTOMIZE menu has been displayed, the CONTENTS page of the menu appears. If the menu has been used before, the last accessed page appears.

- 2 If the CONTENTS page is displayed, turn the MENU SEL/ENTER dial to move the pointer to “EDIT PAGE”, then push on the MENU SEL/ENTER dial to display the EDIT PAGE screen.

If a different page is displayed, turn the MENU SEL/ENTER dial until the EDIT PAGE screen appears, then push on the MENU SEL/ENTER dial to select the page.

	EDIT PAGE	E01	ESC
↓ ↓			
→01	.<VF DISPLAY>		
	02.<'!' IND>		
	03.<MARKER SETTING>		
	04.<VF DETAIL>		
	05.<ZEBRA>		
	06.<MONITOR OUTPUT>		
	07.<PB MONI GAMMA>		
	08.<PB MIX SETTING>		
	09.<CHAR/MARK MIX>		
	10.<SHUTTER ASSIGN>		

- 3 Turn the MENU SEL/ENTER dial to move the pointer to where you wish to add the page, then push on the MENU SEL/ENTER dial.

The EDIT FUNCTION screen appears.

```

EDIT FUNCTION      ESC
→INSERT
MOVE
DELETE

```

- 4 Select INSERT then push on the MENU SEL/ENTER dial.

The selection screen appears.

```

CONTENTS          ESC
↓ ↓
→01 . USER      1
02 . USER      2
03 . USER      3
04 . USER      4
05 . USER      5
06 . USER      6
07 . USER      7
08 . USER      8
09 . USER      9
10 . USER     10

```

- 5 Turn the MENU SEL/ENTER dial to move the pointer to the desired page, then push on the MENU SEL/ENTER dial.

This adds the number and name of the selected page above the item selected in step 3.

To cancel addition of a page

Before pushing the MENU SEL/ENTER dial in step 5, turn the MENU SEL/ENTER dial to move the pointer to “ESC” at the top right of the screen, then push on the MENU SEL/ENTER dial.

The EDIT PAGE screen appears again.

To delete a page

Proceed as follows:

- 1 On the EDIT PAGE screen of the USER MENU CUSTOMIZE menu, move the pointer to the page to be deleted, and push on the MENU SEL/ENTER dial.

The EDIT FUNCTION screen appears.

- 2 Select “DELETE” then push on the MENU SEL/ENTER dial.

The previously displayed page appears again, and the message “DELETE OK?” appears at the upper right.

```

ITEM DELETE      ESC
DELETE OK? →YES NO
01 . <VF DISPLAY>
02 . <'!' IND>
•03 . <MARKER SETTING>
04 . <VF DETAIL>
05 . <ZEBRA>
06 . <MONITOR OUTPUT>
07 . <PB MONI GAMMA>
08 . <PB MIX SETTING>
09 . <CHAR/MARK MIX>
10 . <SHUTTER ASSIGN>

```

- 3 To delete, turn the MENU SEL/ENTER dial to move the pointer to “YES,” then push on the MENU SEL/ENTER dial.

To move a page

Proceed as follows:

- 1 Display the EDIT PAGE screen of the USER MENU CUSTOMIZE menu. Turn the MENU SEL/ENTER dial to move the pointer to the page that you wish to move.

The EDIT FUNCTION screen appears.

- 2 Select “MOVE” then push on the MENU SEL/ENTER dial.

The EDIT PAGE screen appears again.

- 3 Turn MENU SEL/ENTER dial to move the pointer to the position to which you wish to move the page selected in step 1.

```

ITEM MOVE        ESC
↓ ↓
01 . <VF DISPLAY>
02 . <'!' IND>
→03 . <MARKER SETTING>
04 . <VF DETAIL>
05 . <ZEBRA>
06 . <MONITOR OUTPUT>
07 . <PB MONI GAMMA>
•08 . <PB MIX SETTING>
09 . <CHAR/MARK MIX>
10 . <SHUTTER ASSIGN>

```

- 4 Push on the MENU SEL/ENTER dial.

The page selected in step 1 is moved to the position selected in step 3.

In the above example, <PB MIX SETTING> moves to the “03” position, and the <MARKER SETTING> and following pages move down one line.

Returning the USER menu to the factory-set status

Use the <FILE PRESET> page of the FILE menu.

For details, see “5-3-8 Resetting to the Initial Settings” (page 101).

5-1 File Configuration

This system permits various settings and adjustment data to be stored as data files in built-in memory or a “Memory Stick” in order to facilitate later operations or adjustments. A stored data file can be retrieved, as required, to reproduce the stored setting statuses.

Note

In Cine mode, some file operations will be limited.

The following six kinds of files are designed for the system:

Operator file

This file stores operational settings not related to picture quality. At shipment, the operator file with the default settings has been stored in built-in memory. After the default settings are changed, those changed setting data can be stored as the operator file in a “Memory Stick” for later use. For file operation, use the <OPERATOR FILE> page of the USER (OPERATION) menu or that of the FILE menu.

Items stored

The setting items in the OPERATION menu (*page 64*) and the customized USER menu (*page 90*) can be stored.

Lens files

Names of different lenses and standard values for these lenses can be registered in lens files in built-in memory of the camera.

When you remount the lens after using another lens, the appropriate compensation for the lens can be achieved easily by reading the file corresponding to the lens.

Creation and modification of lens files are made in Custom mode.

Adjust necessary items, using the PAINT and MAINTENANCE menus or using the MSU-900/950 Master Setup Unit, then store the adjustment data, using

the <LENS FILE> page of the FILE menu or using the MSU-900/950.

You can back up the lens files in a “Memory Stick.”

Note

In Cine mode, only retrieval of lens files is possible. Modification of file data or file creation is not possible.

Items stored

The items that are stored in lens files are marked with “O” in the “L” column of the table in “5-2 List of Items Stored in Files”.

Scene files

Scene files store data adjusted on the PAINT menu for specific scenes.

For example, if you store data prepared in rehearsal for a particular scene in a scene file, the data can be retrieved to reproduce the same camera settings for the actual take. For file operation, use the <SCENE FILE> page of the PAINT or FILE menu. You can also use the MSU-900/950 Master Setup Unit for the file operation.

Scene files are stored in built-in memory. You can also back up the scene files in a “Memory Stick.”

Note

In Cine mode, scene file operation is disabled.

To use 32 scene files

Set 32 SCENE FILE to ON on the <OTHERS 2> page of the MAINTENANCE menu.

Note

If you return 32 SCENE FILE” to OFF, all scene files No. 6 to 32 are initialized when you next set it to ON. (Scene files No. 1 to 5 are maintained.)

Items stored

The items that are stored in scene files are marked with “O” in the “S” column of the table in “5-2 List of Items Stored in Files”.

Reference file

This file stores the standard settings of the camera that can be used as a reference when adjusting the camera.

If STANDARD is executed on the <SCENE FILE> page of the PAINT menu or the <REFERENCE> page of the FILE menu, or with the MSU-900/950 Master Setup Unit, manually adjusted values of the camera will be reset to the reference values that have been stored in the reference file. At shipment, the reference file with the initial settings is stored in built-in memory.

The initial settings can be modified, as required, then stored as the new reference file.

For file operation, use the <REFERENCE> page of the FILE menu. You can also use the MSU-900/950 Master Setup Unit for file operation.

You can back up the reference file in a “Memory Stick.”

Notes

- In Cine mode, the reference file data are fixed as those at shipment and cannot be modified.
- As relative adjustment values with regard to the reference file data are stored in a scene file, if data of the reference file are modified, the scene files also need modification.

Items stored

The items that are stored in the reference file are marked with “O” in the “R” column of the table in “5-2 List of Items Stored in Files”.

User-Gamma file

The gamma-curve data (User Gamma) created using CvpFileEditor application software can be loaded to the camera via a “Memory Stick.” This enables reproduction of images closer to those that individual users wish to reproduce.

For file operation, use the <USER GAMMA> page of the FILE menu.

The User-Gamma file is stored in built-in memory. Backup of the User-Gamma file in a “Memory Stick” is not possible.

Note

In Cine mode, operation of the User-Gamma file via a “Memory Stick” is not possible.

OHB file

The OHB file stores the offset values of items specific to the CCD unit.

For file operation, use the <OHB FILE> page of the FILE menu. You can also use the MSU-900/950 Master Setup Unit for this operation.

Note

In Cine mode, the OHB file can be retrieved automatically, but the data in the OHB file cannot be modified.

Items stored

The items that are stored in the OHB file are marked with “O” in the “O” column of the table in “5-2 List of Items Stored in Files”.

5-2 List of Items Stored in Files

The items that are stored in scene files, the reference file, the lens files, and the OHB file are listed in the table below.

For details on setting values, see the corresponding items in the table in “4-3 Menu List” (page 64).

S: Scene file
R: Reference file
L: Lens file
O: OHB file

Menu page (No. in Custom mode)	Item	S	R	L	O
<VIDEO LEVEL> (P02)	WHITE [R] [G] [B]	○	○		
	WHITE [R] [B]	○	○	○	
	BLACK [R] [G] [B] [M]	○	○		
	FLARE [R] [G] [B]	○	○	○	
	FLARE ON/OFF	○	○		
<GAMMA> (P03)	LEVEL [R] [G] [B] [M]	○	○		
	BLACK [M]	○	○		
	COARSE	○	○		
	TABLE	○	○		
	GAMMA ON/OFF	○	○		
<BLACK GAMMA> (P04)	LEVEL [R] [G] [B] [M]	○	○		
	RANGE	○	○		
	RANGE ON/OFF	○	○		
	BLACK GAMMA ON/OFF	○	○		
<SATURATION> (P05)	SATURATION	○	○		
	SATURATION ON/OFF	○	○		
	LOW KEY SAT	○	○		
	RANGE	○	○		
<KNEE> (P06)	K POINT [R] [G] [B] [M]	○	○		
	K SLOPE [R] [G] [B] [M]	○	○		
	KNEE ON/OFF	○	○		
	KNEE SAT	○	○		
	KNEE SAT ON/OFF	○	○		
	AUTO KNEE	○	○		
	POINT LIMIT	○	○		
	SLOPE	○	○		
<WHITE CLIP> (P07)	W CLIP [R] [G] [B] [M]	○	○		
	W CLIP ON/OFF	○	○		

Menu page (No. in Custom mode)	Item	S	R	L	O
<DETAIL 1> (P08)	DETAIL ON/OFF	○	○		
	LEVEL	○	○		
	LIMITER M	○	○		
	LIMITER WHT	○	○		
	LIMITER BLK	○	○		
	CRISP	○	○		
	LVL DEP	○	○		
	LVL DEP ON/OFF	○	○		
<DETAIL 2> (P09)	H/V RATIO	○	○		
	FREQ	○	○		
	MIX RATIO	○	○		
	KNEE APT	○	○		
<SKIN DETAIL> (P10)	KNEE APT ON/OFF	○	○		
	SKIN DTL ON/OFF	○	○		
	PHASE	○	○		
	WIDTH	○	○		
<USER MATRIX> (P11)	SAT	○	○		
	LEVEL	○	○		
	R-G	○	○		
	R-B	○	○		
	G-R	○	○		
	G-B	○	○		
	B-R	○	○		
	B-G	○	○		
	MATRIX ON/OFF	○	○		
	USER MATRIX ON/OFF	○	○		
<MULTI MATRIX> (P12)	MULTI MATRIX ON/OFF	○	○		
	HUE	○	○		
<SHUTTER/FPS> (P13)	SAT	○	○		
	SHUTTER	○	○		
<NOISE SUPPRESS> (P15)	VAR	○	○		
	NOISE SUP	○	○		
<WHITE SHADING> (M03)	LEVEL	○	○		
	V SAW [R] [G] [B]			○	○
	V PARA [R] [G] [B]			○	○
	H SAW [R] [G] [B]			○	○
	H PARA [R] [G] [B]			○	○

Menu page (No. in Custom mode)	Item	S	R	L	O
<BLACK SHADING> (M04)	V SAW [R] [G] [B]				○
	V PARA [R] [G] [B]				○
	H SAW [R] [G] [B]				○
	H PARA [R] [G] [B]				○
	BLK SET [R] [G] [B]				○
	MASTER GAIN	○	○		
<OHB MATRIX> (M05)	HUE				○
	SAT				○
	OHB MATRIX				○
ND filter selection	○				
ND offset				○	

5-3 File Operations

5-3-1 Using a “Memory Stick”

You can use “Memory Stick PRO” media with this camera. “Memory Stick PRO Duo” can also be used without using a Memory Stick Duo adaptor.

The camera operations have been checked using “Memory Stick PRO” media up to 8GB.

Operations checked with:

MSH-128
MSX-512S
MSX-M2GS
MSX-M4GS
MSX-M8GS

For details on “Memory Stick” media, see “About a “Memory Stick”” (page 116).

Inserting a “Memory Stick”

Insert a “Memory Stick” with the label side up into the “Memory Stick” slot until it clicks and the access lamp lights in red. When the “Memory Stick” is properly set, the lamp illumination changes to green.

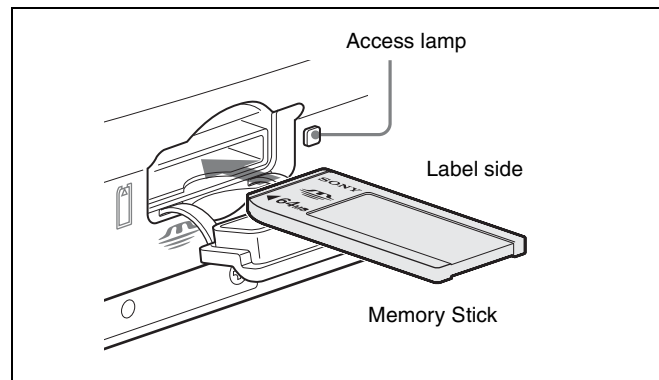

If it does not fit into the slot properly or if there is some resistance when you insert it, the “Memory Stick” may be turned around or upside-down. Do not force the “Memory Stick” into the slot. Confirm the direction of the notch and arrow on the “Memory Stick” before inserting the “Memory Stick,” and then try inserting it again.

Removing the “Memory Stick”

Confirm that the access lamp is not lit in red, then lightly push in the “Memory Stick” to release the lock.

Note

If the access lamp is lit in red, data are being read from or written to the “Memory Stick” At this time, do not shake

the product or subject it to shock. Do not turn off the power to the product or remove the “Memory Stick.” This may damage the data.

Protecting saved data

To prevent accidental erasure of important setup data, use the LOCK switch on the “Memory Stick.”

Slide the switch right to the write protect position. This ensures that you cannot inadvertently overwrite data on the “Memory Stick.”

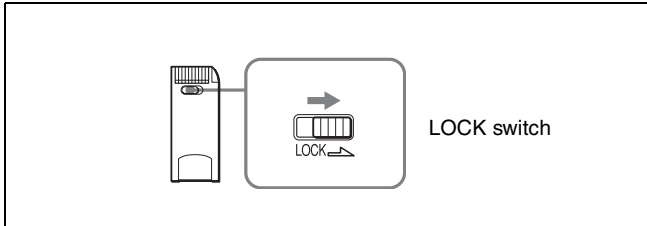

Notes on using and storing the “Memory Stick”

- Avoid touching the connector of the “Memory Stick” or contacting it with a metal object.
- When attaching a label to the “Memory Stick,” use only the label supplied for the “Memory Stick.”
- Do not drop, bend, or submit the “Memory Stick” to external shock.
- Do not disassemble or modify the “Memory Stick.”
- Avoid getting liquids on the “Memory Stick.”
- Avoid using or storing the “Memory Stick” in a location subject to:
 - extremely high temperature such as the hot inside of a car or the outdoors exposed to a burning sun, or a place near a heater
 - direct sunlight
- When storing and carrying the “Memory Stick,” keep it in its original case to ensure protection of important data.
- Do not format the “Memory Stick” using a PC. Formatting of the “Memory Stick” can be performed on the <FILE PRESET> page of the FILE menu.

To format a “Memory Stick”

Use the <FILE PRESET> page of the FILE menu.

- 1 Insert a “Memory Stick” you wish to format into the “Memory Stick” slot of the camera.
- 2 Call up the <FILE PRESET> page of the FILE menu.
- 3 Position the pointer to M.S. FORMAT and push on the MENU SEL/ENTER dial.

```

<FILE PRESET>      F07 TOP
OPERATOR FILE
USER GAMMA FILE
LENS FILE
REFERENCE FILE
10 SEC CLEAR: OFF
OHB FILE
USER MENU
→M.S. FORMAT
FILE PRESET (-OHB)
  
```

During formatting, “MEMORY STICK ACCESS” is displayed.

When formatting is completed, “COMPLETE” is displayed.

5-3-2 Storage and Retrieval of the Operator File

Use the <OPERATOR FILE> page of the FILE menu.

```

<OPERATOR FILE>  F01 TOP
READ (MS →CAM)
WRITE (CAM→MS )
PRESET
FILE ID:
CAM CODE
DATE
  
```

The <OPERATOR FILE> page is also included in the USER (OPERATION) menu (*see page 56*).

To store the operator file in a “Memory Stick”

Perform necessary settings for the operation items and the customized USER menu for the operator file you wish to store.

- 1 Insert a “Memory Stick” into the “Memory Stick” slot of the camera.
- 2 Position the pointer to WRITE (CAM → MS) and push on the MENU SEL/ENTER dial.

You can add a comment (maximum: 14 characters) to the operator file to be stored in the “Memory Stick” by specifying it on the FILE ID line.

For details on how to enter a comment, see “Specifying a character string” (page 63).

To retrieve the operator file stored in a “Memory Stick”

The operator file stored in the “Memory Stick” can be read out into built-in memory of the camera.

- 1 Insert the “Memory Stick” into the “Memory Stick” slot of the camera.
- 2 Position the pointer to READ (MS → CAM) and push on the MENU SEL/ENTER dial.

The camera will be set according to the data loaded from the operator file.

To return the operator file items to the factory-set values

Position the pointer to PRESET and push on the MENU SEL/ENTER dial.

You can also use the <FILE PRESET> page (page 101) of the FILE menu for this purpose.

5-3-3 Registration and Retrieval of the Lens Files

The registered lens files can be retrieved via the subdisplay or the <LENS FILE> page of the OPERATION menu.

To register the data you adjusted for the mounted lens as a lens file, or to use a “Memory Stick,” the <LENS FILE> page of the FILE menu is used.

```

<LENS FILE>          F05 TOP
  →STORE FILE
No. : 1
NAME: No Offset
CENTER H : 0
        V : 0   STORE
WHITE R/B: ON
LENS MS READ/WRITE
  
```

To store the data as a lens file in built-in memory

Perform necessary settings for the items marked with “○” in the L column of the table in “5-2 List of Items Stored in Files” for the lens file you wish to store.

- 1 Select the file number, and set the file name.

For setting of file names, see “Specifying a character string” (page 63).

- 2 Position the pointer to STORE FILE and push on the MENU SEL/ENTER dial.

Storage of the position settings for the center marker can be independently performed.

You can confirm the effect of the WHITE R/B compensation that has been set in the file, by changing the setting for WHITE R/B to OFF.

Note

The WHITE R/B item is provided only for confirming the effect of compensation (comparison between when the file is used and not used). The file cannot be stored with WHITE R/B set to OFF.

To store in or retrieve from a “Memory Stick”

Position the pointer to LENS MS READ/WRITE and push on the MENU SEL/ENTER dial. The subpage will be displayed.

```

<LENS FILE>          ESC
  READ (MS →CAM)
  WRITE (CAM→MS )
FILE ID:
CAM CODE
DATE
  
```

To store

Position the pointer to WRITE (CAM → MS) then push on the MENU SEL/ENTER dial.

You can add a comment (maximum: 14 characters) to the lens file to be stored in the “Memory Stick” by specifying it on the FILE ID line.

For details on how to enter a comment, see “Specifying a character string” (page 63).

To retrieve

Position the pointer to READ (MS → CAM) then push on the MENU SEL/ENTER dial.

5-3-4 Storage and Retrieval of the Scene Files

Use the <SCENE FILE> page of the FILE menu. The <SCENE FILE> page is also included in the PAINT menu. The operation method is the same.

```

<SCENE FILE>        F02 TOP
  1  2  3  4  5  STORE
  --
  STANDARD
  READ (MS →CAM)
  WRITE (CAM→MS )
FILE ID:
CAM CODE
DATE
  
```

To store a scene file in built-in memory

Perform necessary settings for the items for the scene file you wish to store.

- 1 Position the pointer to STORE and push on the MENU SEL/ENTER dial.
- 2 Position the pointer to the number of the file in which you wish to store your settings and push on the MENU SEL/ENTER dial.

During the storage process, “MEMORY STICK ACCESS” is displayed.

When storage is completed, “COMPLETE” is displayed.

To retrieve a scene file stored in built-in memory

Position the pointer to the number of the file that you wish to retrieve and push on the MENU SEL/ENTER dial. The statuses specified in the retrieved file will be reproduced.

Setting 32 SCENE FILE to ON on the <OTHERS 2> page of the MAINTENANCE menu expands the number of usable scene files to 32.

Note

If you return 32 SCENE FILE to OFF, all scene files No. 6 to 32 are initialized when you next set it to ON. (Scene files No. 1 to 5 are maintained.)

To store the scene files in a “Memory Stick”

Scene files stored in built-in memory of the camera can be read out to a “Memory Stick.”

- 1 Insert a “Memory Stick” into the “Memory Stick” slot of the camera.
- 2 Position the pointer to WRITE (CAM → MS) and push on the MENU SEL/ENTER dial.

You can add a comment (maximum: 14 characters) to the scene files to be stored in the “Memory Stick” by specifying it on the FILE ID line.

For details on how to enter a comment, see “Specifying a character string” (page 63).

To retrieve scene files stored in a “Memory Stick”

Scene files stored in the “Memory Stick” can be read out into built-in memory of the camera.

- 1 Insert the “Memory Stick” into the “Memory Stick” slot of the camera.

- 2 Position the pointer to READ (MS → CAM) and push on the MENU SEL/ENTER dial.

5-3-5 Storage and Retrieval of the Reference File

Use the <REFERENCE> page of the FILE menu.

```
<REFERENCE>      F03 TOP
STORE FILE
STANDARD
READ (MS →CAM)
WRITE (CAM→MS )
FILE ID:
CAM CODE
DATE
```

To retrieve the reference file (standard settings) stored in built-in memory

Position the pointer to STANDARD and push on the MENU SEL/ENTER dial.

To store the reference file in built-in memory

Perform necessary settings for the reference-file items you wish to store.

Position the pointer to STORE FILE and push on the MENU SEL/ENTER dial.

To store the reference file in a “Memory Stick”

- 1 Insert a “Memory Stick” into the “Memory Stick” slot of the camera.
- 2 Position the pointer to WRITE (CAM → MS) and push on the MENU SEL/ENTER dial.

You can add a comment (maximum: 14 characters) to the reference file to be stored in the “Memory Stick” by specifying it on the FILE ID line.

For details on how to enter a comment, see “Specifying a character string” (page 63).

To retrieve the reference file stored in the “Memory Stick”

The reference file stored in the “Memory Stick” can be read out into built-in memory of the camera.

- 1 Insert the “Memory Stick” into the “Memory Stick” slot of the camera.

- 2 Position the pointer to READ (MS → CAM) and push on the MENU SEL/ENTER dial.

The camera will be adjusted according to the data of the reference file.

5-3-6 Reading of the User Gamma

To read out gamma-curve (User Gamma) data that have been created using CvpFileEditor application software from the “Memory Stick,” use the <USER GAMMA> page of the FILE menu.

```
<USER GAMMA>      F04 TOP
  →READ (MS →CAM)

FILE ID
CAM CODE
DATE
```

Insert the “Memory Stick” into the “Memory Stick” slot of the camera. Position the pointer to READ (MS → CAM) and push on the MENU SEL/ENTER dial.

For details on how to use the User Gamma, see “3-11-4 Using the User Gamma” (page 57).

5-3-7 Storage of the OHB File

Use the <OHB FILE> page of the FILE menu.

- 1 Execute STANDARD on the <REFERENCE> page of the FILE menu.
- 2 Using the MAINTENANCE menu, perform necessary settings for the items marked with “O” in the “O” column of the table in “5-2 List of Items Stored in Files” for the file you wish to store.
- 3 Call up the <OHB FILE> page of the FILE menu, position the pointer to STORE FILE then push on the MENU SEL/ENTER dial.

```
<OHB FILE>      F06 TOP
  →STORE FILE
```

Adjusting the ND offset values

If an ND filter is attached to the matte box, etc., the white balance may be in variance. In such a case, adjust the ND offset so that you can retrieve the white balance compensation value using the ND filter selection page on the subdisplay.

The offset values ND: 2 to 5 are stored with respect to the white balance stored for ND: 1 as the reference.

Adjustment procedure

- 1 Switch the camera to Custom mode, referring to “3-1-2 Switching of the Basic Operation Modes” (page 30).
- 2 Execute STANDARD on the <REFERENCE> page of the FILE menu.
- 3 Execute AUTO BLACK on the <AUTO SETUP> page of the MAINTENANCE menu.
- 4 Connect a waveform monitor via the MONITOR OUT HD SDI connector 1 or 2 of the camera.
- 5 Attach the ND filter having the lowest permeability among the ND filters to be used with this camera, and shoot a gray-scale chart.

Check that the lighting condition permits a video level in the range of 560 to 630 mV to be obtained and write down the current video level.

Note

If a video level in the range of 560 to 630 mV cannot be obtained, do not adjust the ND offsets.

- 6 Attach the ND filter to be used as the reference for white balance adjustment and select ND: 1.
- 7 Adjust the iris of the lens so that the video level you wrote down in step 5 is obtained.
- 8 Perform the auto white balance adjustment.
- 9 Replace the ND filter, change to ND: 2, and repeat steps 7 and 8.
- 10 Replace the ND filter, change to ND: 3 and repeat steps 7 and 8.
- 11 Replace the ND filter, change to ND: 4 and repeat steps 7 and 8.
- 12 Replace the ND filter, change to ND: 5 and repeat steps 7 and 8.

- 13** Store the ND offset values in the OHB file, by executing STORE FILE on the <OHB FILE> page of the FILE menu.

Note

Be sure to accurately adjust to the video level you noted in step 5. If the level is not obtained through the iris adjustment of the lens, use the shutter function or the master gain adjustment.

To use the ND offset values

An appropriate offset value is automatically retrieved when you change the ND filter setting.

To initialize the ND offset values

Perform ND OFFSET on the <OHB FILE> page (subpage of the <FILE PRESET> page of the FILE menu).

To reset the data of the OHB file

In a case of the OHB file, resetting can be performed by item.

Position the pointer to OHB FILE then push on the MENU SEL/ENTER dial. The <OHB FILE PRESET> page will be displayed.

```

<OHB FILE PRESET>   ESC
  →WHITE SHADING (ALL)
    3D WHITE SHADING
    BLACK SHADING
    BLACK SET
    NO OFFSET
    MATRIX
  
```

Position the pointer to the item you wish to reset then push on the MENU SEL/ENTER dial.

5-3-8 Resetting to the Initial Settings

With the <FILE PRESET> page of the FILE menu, data in the modified files or the configuration of the edited USER menu can be reset to the initial settings, by type of files or collectively.

```

<FILE PRESET>      F07 TOP
  →OPERATOR FILE
    USER GAMMA FILE
    LENS FILE (ALL)
      No. : 1 CLEAR: EXEC
    REFERENCE FILE
      10 SEC CLEAR: OFF
    OHB FILE
    USER MENU
    M.S. FORMAT
    FILE PRESET (-OHB)
  
```

To reset data of files by type of files

To reset data of the operator file, User-Gamma file, and reference file

Position the pointer to the corresponding line then push on the MENU SEL/ENTER dial.

The data in the corresponding file in built-in memory will be reset to the initial settings.

The configuration of the USER menu can be reset in the same manner.

To reset data of the lens files

- To reset data of all lens files, position the pointer to LENS FILE (ALL) and push on the MENU SEL/ENTER dial.
- To reset data of a specific lens file, assign the file number in the No. column and push on the MENU SEL/ENTER dial to position the pointer to the CLEAR column. Then push on the MENU SEL/ENTER dial again.

To reset a specific item in the reference file to the initial setting

The items in the reference file can be reset individually.

- 1** On the <FILE PRESET> page, set 10 SEC CLEAR to ON.
- 2** Shift to the menu page on which the item you wish to reset is located. Position the pointer to the item you wish to reset then hold the MENU SEL/ENTER dial pressed.

Continue to hold the MENU SEL/ENTER dial pressed after the pointer changes to a question mark (?).

After about 3 seconds, the current setting of the corresponding item will be reset to the initial setting, and "CLEARED" will be displayed.

If the dial is continuously held pressed, after about additional 7 seconds, the setting of the corresponding item that is stored in the reference file will be reset to the initial setting, and "REF CLEARED" will be displayed.

To reset the files and settings collectively

All files except the OHB file can be reset simultaneously. Position the pointer to FILE PRESET (-OHB) on the <FILE PRESET> page then push on the MENU SEL/ENTER dial. The message "POWER OFF TO SET" will be displayed. Set the POWER switch of the camera to OFF.

Appendixes

Using the RM-B750

When the RM-B750 Remote Control Unit (optional) is connected, you can control the menu settings of this camera and monitor the camera images on the display of the RM-B750.

Connection

Using the remote control cable supplied with the RM-B750, connect the CAMERA connector of the RM-B750 and the REMOTE connector of the camera.

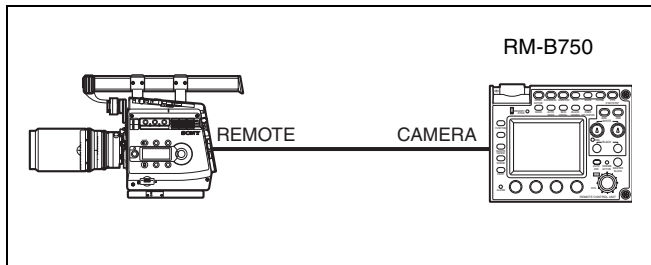

Operating the Menu of This Camera

The menu of this camera can be displayed on the display of the RM-B750 and be set from the RM-B750.

Settings on this camera

- Set RM VIDEO to VBS on the <MONITOR OUTPUT> page of the USER (OPERATION) menu.
- Set VBS of CHAR to ON on the <CHAR/MARK MIX> page of the USER (OPERATION) menu.
- Set NS MODE to LEGACY on the <700PTP SETTING> page of the NETWORK menu.

Settings on the RM-B750

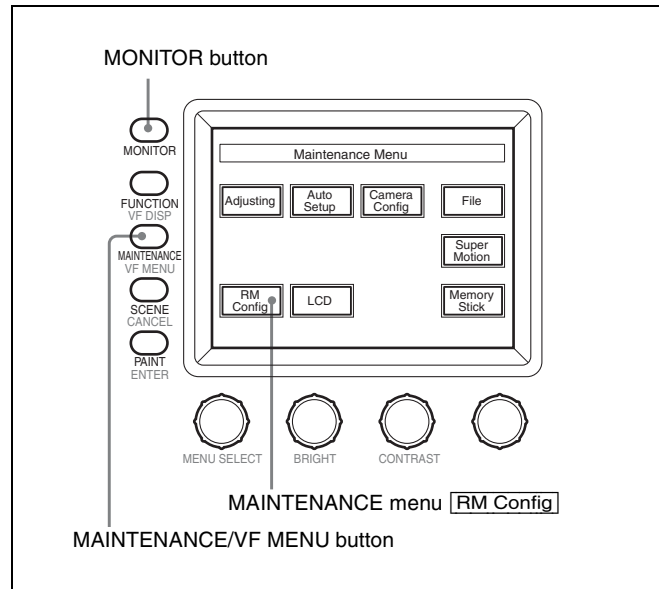

- 1 Press the MAINTENANCE/VF MENU button to display the maintenance menu on the LCD/touch panel.
- 2 Press **[RM Config]** on the touch panel to display the RM configuration menu.
- 3 Press **[Security]** to set the unit to Engineering Mode.
- 4 Press **[SW Setting]** to change to the SW Setting display and set the VF Menu to Control Enable.
- 5 Press **[Exit]** to cancel the menu mode.

If you press the MONITOR button, a menu page of this camera will be displayed on the display of the RM-B750. Pressing the MAINTENANCE/VF MENU button enables the menus of this camera to be set from the RM-B750.

For details on the operations, refer to the Operation Manual of the RM-B750.

Monitoring the Camera Image

Settings on this camera

Set RM VIDEO to VBS on the <MONITOR OUTPUT> page of the USER (OPERATION) menu.

Settings on the RM-B750

Press the MONITOR button. The camera image will be displayed on the display of the RM-B750.

VBS signals are fed to an external monitor if connected via the MONITOR connector of the RM-B750.

Using the MSU-900/950

You can adjust this camera from the MSU-900/950 Master Setup Unit via an Ethernet cable.

You can use either Bridge mode to control a camera from an exclusive MSU-900/950 or Multi mode to control multiple cameras from one MSU-900/950 or from multiple remote controllers, including the MSU-900/950 via a HUB.

Connections

Bridge mode

For using one camera on an Ethernet network.

Using an Ethernet cable, connect the MSU-900/950 to the  (network) connector of this camera.

You may use the remote cable connection simultaneously.

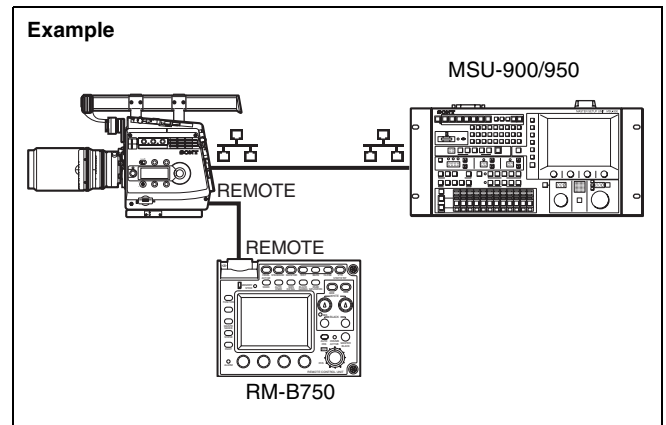

Multi (MCS) mode

Connect the Ethernet cable connected to the  (network) connector of this camera to the HUB.

You may use the remote cable connections simultaneously.

Notes

- Remote cable connections will be invalid if the master unit is not connected to the same network.
- If the master-specified MSU-900/950 is off, all the network/remote communications are disabled.
- Do not connect devices having the same IP address to the network.
- Do not connect cameras having the same ID number to the network. Communications would be disabled on both cameras.

Example

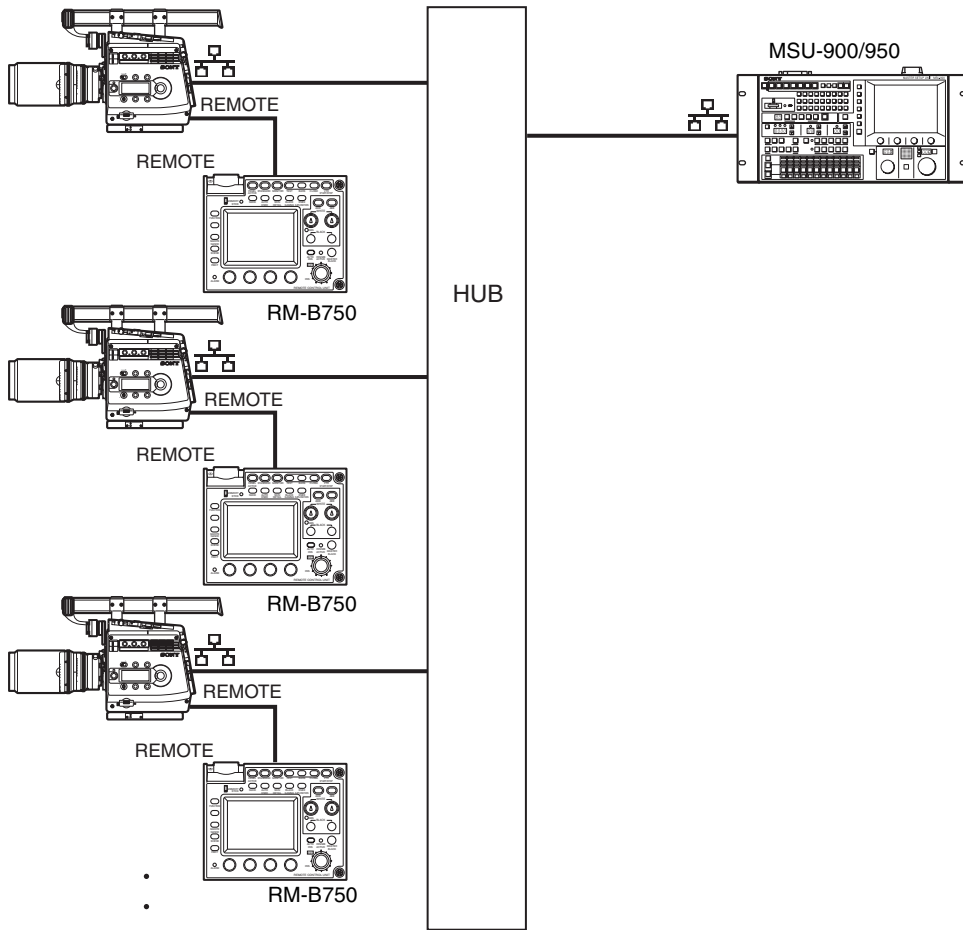

Parameter Settings

Settings on the camera

Set the communication parameters using the NETWORK menu.

page	Item	Setting in Bridge mode	Setting in Multi mode
<IP ADDR SET>	HOST IP ADDRESS	IP address specific to the camera	←
	SUBNET MASK	Value corresponding to the network environments in use	←
	DEFAULT GATEWAY	Value corresponding to the network environments in use	←
<ETHER I/F CONF>	AUTO NEGOTIATION	ON ¹⁾ or OFF	←
	CONNECT SPEED	No setting required if AUTO NEGOTIATION is set to ON. For the OFF setting, select 10M or 100M.	←
	DUPLEX MODE	Select HALF or FULL.	←
<700PTP SETTING>	NS MODE	BRIDGE	MCS
	CAMERA NO.	No setting required	ID number specific to the camera
	MASTER IP ADDRESS	Set the IP address of the MSU-900/950 connected.	Set the IP address of the master MSU-900/950.

1) While the connection may be steady with the ON setting, the performances are improved with an OFF setting for the collateral condition.

Settings on the MSU-900/950

Set the unit to Engineer mode and set the communication parameters, using the Ethernet Configuration menu.

For details on operations, refer to the Operation Manual of the MSU-900/950.

Menu	Item	Setting in Bridge mode	Setting in Multi mode	
			Master unit	Subordinate unit(s)
Connection	Mode selection	Bridge	MCS	
	Target IP SET	IP addresses of the connected cameras	No setting required	
	Master IP SET	No setting required		IP address of the master unit
	Master/Client selection	No setting required	Client	←
	MSU No.	No setting required	1	2
Negotiation	Negotiation	AUTO or OFF	←	←
	Speed	No setting required if Negotiation is AUTO. For the OFF setting, select 10M or 100M.	←	←
	Duplex	No setting required if Negotiation is AUTO. For the OFF setting, select HALF or FULL.	←	←
IP Address Setting	IP Address	IP address specific to the MSU	←	←
	Net Mask	Value corresponding to the network environments in use	←	←
	Gateway Address	Value corresponding to the network environments in use	←	←

Notes on Ethernet connection

- For stable operations of the connected devices, use the system in a local network, without connecting to the Internet.
- Do not connect any device to the local network other than the system units for this camera.

Recommended remote control devices for which operation tests have been made

Sony made

- MSU-900/950
- RM-B750

Equipment from other vendors

HUB CentreCOM FS909M-PS

Using the ARRI Remote Control

You can display or change the following items on/from the ARRI-made WRC-2 (Wireless Remote Control 2).

Items that can be displayed on the WRC-2

- Model name of this camera (F35)
- System format, input voltage to the camera, tape remaining of the recorder, shutter speed (sec.), time code, tape loading status of the recorder¹⁾
- Flashing reminders for battery remaining and tape remaining

Items that can be changed from the WRC-2

- Frame rate (FPS)²⁾
- Starting and ending values for the shutter angle in a Ramp operation
- Starting and ending values for the frame rate (FPS) in a Ramp operation²⁾
- Shutter compensation mode (COMP MODE: ANGLE, GAIN, OFF)
- RUN mode of the recorder (recording start/stop)¹⁾

1) The menu display on the WRC-2 is shown in red if no tape is loaded, in pale blue if a tape has been loaded but is not running, or in green when the loaded tape is running.

2) Displayed as Speed on the WRC-2

Connection and preparations

Two types of connection are permitted: direct wiring to the EXT I/O connector of the camera and wireless connection via the UMC-3 (Universal Motor Controller).

Notes

- In either case, a special cable is required.
- For the WRC-2, version updating is required.
- For the UMC-3, modification for 12 V power or use of the UMC-3A is required.

For details on ARRI products, contact ARNOLD & RICHTER CINE TECHNIK.

About Metadata

Metadata that can be embedded in recording and can be read in playback are shown below:

USER 1

Data types

U-Hex: unsigned hexadecimal S-Hex: signed hexadecimal ASCII: ASCII code BCD: binary-coded decimal

Sample No.	Data size (byte)	Relative address		Data type	Bit	Name	Recorded data (HEX)	Contents
0	3					Ancillary Data Flag	000h	
1							3FFh	
2							3FFh	
3	1					DID	51h	
4	1					SDID	01h	
5	1					DC	42h	Data Count (from "Key" to "CRC")
6	1	0	00			Key	F0h	USER1
7	1	1	01			Length	3Eh	Data Length (from next to "Length" to before "CRC")
8	2	2	02	U-Hex		Model Name	2022h	
9		3	03					
10	3	4	04	U-Hex		Serial No		Serial number (6 digits)
11		5	05					
12		6	06					
13	4	7	07	U-Hex		Frame Number		Frame counter
14		8	08					
15		9	09					
16		10	0A					
17	1	11	0B	U-Hex		System Format		Subtable 1 (<i>see page 111</i>)
18	1	12	0C	U-Hex		FPS		1 to 60 (frame/sec)
19	5	13	0D	ASCII		Shutter Angle		4.3 to 360.0 (For a value with fewer than 5 digits, the unused leading digits are padded with spaces. Example. _ _4.3)
20		14	0E					
21		15	0F					
22		16	10					
23		17	11					
24	5	18	12	ASCII		Shutter Speed		1.000 to 5600 (1/sec) (For a value with fewer than 5 digits, the unused leading digits are padded with spaces.)
25		19	13					
26		20	14					
27		21	15					
28		22	16					
29	2	23	17	U-Hex		ISO		220 to 2300
30		24	18					
31	2	25	19	U-Hex		D-Range %		250 to 800 (%)
32		26	1A					
33	1	27	1B	U-Hex		Master Gain		Subtable 2 (<i>see page 111</i>)

Sample No.	Data size (byte)	Relative address		Data type	Bit	Name	Recorded data (HEX)	Contents
34	1	28	1C	U-Hex		ND		1: ND_1, 2: ND_2, 3: ND_3, 4: ND_4, 5: ND_5
35	1	29	1D	U-Hex		(reserved)		
36	1	30	1E	U-Hex		Color Space		0: S-GAMUT, 1: F900, 2: DCDM REF PJ, 3: F900R
37	1	31	1F	U-Hex		Compensation Mode		0: OFF, 1: GAIN, 2: ANGLE
38	1	32	20	U-Hex		Gamma Table Category		0: STANDARD, 1: SPECIAL, 2: HYPER, 3: USER
39	1	33	21	U-Hex		Gamma Table No		1 to 5 (Current No. of gamma table category)
40	1	34	23	U-Hex		Lens File No		1 to 32
41	1	35	25		7	(reserved)		
					6	(reserved)		
					5	(reserved)		
					4	Shoot mode CINE		0: CUSTOM MODE, 1: CINE MODE
					3	D-Range EXTEND		0: NORMAL, 1: EXTEND
					2	IMAGE INVERT ON		0: OFF, 1: INVERT ON
					1	5600K ON		0: OFF, 1: 5600K ON
					0	Shutter ON		0: OFF, 1: SHUTTER ON
42	1	36	23	U-Hex		Data Year Upper	00 to 99	
43	1	37	25	U-Hex		Date Month	1 to 12	
44	1	38	26	U-Hex		Date Day	1 to 31	
45	3	39	27	U-Hex		Time Hour		0 to 23
46		40	28	U-Hex		Time Minute		0 to 59
47		41	29	U-Hex		Time Second		0 to 59

Sample No.	Data size (byte)	Relative address		Data type	Bit	Name	Recorded data (HEX)	Contents																																							
48		42	2A		31																																										
					30																																										
					29																																										
					28																																										
					27																																										
					26																																										
					25																																										
					24																																										
49	4	43	2B	U-Hex	23	Camera Warning		(reserved)																																							
					22																																										
					21																																										
					20																																										
					19																																										
					18																																										
					17																																										
					16																																										
50		44	2C		15																																										
					14																																										
					13																																										
					12																																										
					11																																										
					10																																										
					9																																										
					8																																										
51		45	2D		7																																										
					6																																										
					5																																										
					4																																										
					3																																										
					2																																										
					1																																										
					0																																										
52	2	46	2E	U-Hex		VTR Warning		Subtable 3 (see page 111)																																							
53		47	2F						54	1	48	30	ASCII		Camera Main CPU Version No.1		Version X. xx	55	1	49	31	ASCII		Camera Main CPU Version No.2		Version x. Xx	56	1	50	32	ASCII		Camera Main CPU Version No.3		Version x. xX	57	1	51	33	ASCII		Camera Main CPU Suffix 1		Version x. xxXxxx	58	1	52
54	1	48	30	ASCII		Camera Main CPU Version No.1		Version X. xx																																							
55	1	49	31	ASCII		Camera Main CPU Version No.2		Version x. Xx																																							
56	1	50	32	ASCII		Camera Main CPU Version No.3		Version x. xX																																							
57	1	51	33	ASCII		Camera Main CPU Suffix 1		Version x. xxXxxx																																							
58	1	52	34	ASCII		Camera Main CPU Suffix 2		Version x. xxxXxx																																							

Sample No.	Data size (byte)	Relative address		Data type	Bit	Name	Recorded data (HEX)	Contents
59	1	53	35	ASCII		Camera Main CPU Suffix 3		Version x. xxxxXx
60	1	54	36	ASCII		Camera Main CPU Suffix 4		Version x. xxxxxX
61	1	55	37	U-Hex		Audio Delay		Subtable 4 (<i>see page 112</i>)
62	1	56	38	U-Hex	7	Timecode Type 0		(reserved)
					6			(reserved)
					5			
					4			00: TCR, 01: TCG
					3			00: LTC, 01: VITC, 10: LTC+VITC
					2			
					1			00: TC, 01: UB, 10: CTL
					0			
63	1	57	39	U-Hex	7	Timecode Type 1		(reserved)
					6			(reserved)
					5			CTL 0:24H, 1: 12H
					4			(reserved)
					3			TCR interpolation 0: OFF, 1: ON
					2			(reserved)
					1			
					0			TCR DF/NDF 01: DF, 10: NDF
64	1	58	3A	BCD		Timecode Hour	-11 to 11 or 0 to 23 ^{1) 2) 3)}	
65	1	59	3B	BCD		Timecode Minute	00 to 59 ⁴⁾	
66	1	60	3C	BCD		Timecode Second	00 to 59 ⁴⁾	
67	1	61	3D	BCD		Timecode Frame	00 to 59 ¹⁾	
68	2	62	3E	U-Hex		Dummy		(reserved)
69		63	3F					
70	1					CRC		
71	1					CKSUM		
72	1							
	73					Total Size		Total size (from "ADF" to "CKSUM")

- 1) When the timecode type is UB (user bits), the entire byte is used. With other timecode types, 6 bits (b5 to b0) are used. Ignore b7 and b6.
- 2) When ±12H CTL display is selected, the tens digit of the hours value is dropped for values less than 10.
- 3) When the timecode type is CTL, b7 is used for the sign.
- 4) When the timecode type is UB (user bits), the entire byte is used. With other timecode types, 7 bits (b6 to b0) are used. Ignore b7.

1. System Formats

Sample No. 17 System Format		
Code		Video format
DEC	HEX	
0	00	No Assign 4:4:4
1	01	1080/23.98PsF 4:4:4
2	02	1080/S23.98PsF 4:4:4
3	03	1080/24PsF 4:4:4
4	04	1080/S24PsF 4:4:4
5	05	1080/25PsF 4:4:4
6	06	1080/S25PsF 4:4:4
7	07	1080/29.97PsF 4:4:4
8	08	1080/S29.97PsF 4:4:4
9	09	(reserved)
10	0A	1080/S30PsF 4:4:4
11	0B	(reserved)
12	0C	1080/S50P 4:4:4
13	0D	(reserved)
14	0E	1080/S60P 4:4:4
15	0F	(reserved)
16	10	1080/S59.94P 4:4:4
17	11	1080/50I 4:4:4
18	12	1080/59.94I 4:4:4

Sample No. 17 System Format		
Code		Video format
DEC	HEX	
19	13	(reserved)
20	14	1080/23.98PsF 4:2:2
21	15	1080/S23.98PsF 4:2:2
22	16	1080/24PsF 4:2:2
23	17	1080/S24PsF 4:2:2
24	18	1080/25PsF 4:2:2
25	19	1080/S25PsF 4:2:2
26	1A	1080/29.97PsF 4:2:2
27	1B	1080/S29.97PsF 4:2:2
28	1C	(reserved)
29	1D	1080/S30PsF 4:2:2
30	1E	1080/50P 4:2:2
31	1F	1080/S50P 4:2:2
32	20	(reserved)
33	21	1080/S60P 4:2:2
34	22	(reserved)
35	23	1080/S59.94P 4:2:2
36	24	1080/50I 4:2:2
37	25	1080/59.94I 4:2:2
38	26	(reserved)

2. Master Gain

Sample No. 33 Master gain	
Code	Master gain
0	-6 dB
1	-3 dB
2	0 dB
3	3 dB
4	6 dB
5	9 dB
6	12 dB
7	15 dB
8	18 dB

3. VTR Warning

Sample No. 52 and 53 VTR Warning		
Code	VTR message	Meaning
0001	PB FREQ MISMATCH	System frequency of this system does not match system frequency on the tape.
0004	NO PB LTC	Playback LTC cannot be detected.

Sample No. 52 and 53 VTR Warning		
Code	VTR message	Meaning
0005	NO PB VITC	Playback VITC cannot be detected.
0007	REC INHIBIT MODE	The system cannot record because of a record inhibit menu setting. Or the tape is not formatted for recording.
0008	INVALID FMT CONV	Format conversion is not possible with the current settings.
0009	TEMPERATURE LOW	The temperature inside the unit is lower than the specified value.
000C	DC VOLTAGE LOW	DC voltage has fallen below the specified level.
000E	TEMPERATURE HIGH	The temperature inside the unit has risen.
000F	VA MISSING	SRPC-1 is not connected.
0010	TELEFILE FULL	Telefile memory is almost full. The next recording will erase existing data, beginning with oldest.
0011	TELEFILE NO ROOM	Free memory in a Telefile has been completely exhausted.
0013	TELEFILE FMT NG	Telefile format is invalid in 1 or more locations.
0014	TELEFILE RD FAIL	Telefile read failure occurred.
0015	TELEFILE WR FAIL	Telefile write failure occurred.
0016	TELEFILE WR INHI	Attempt to record was made when entire Telefile is write inhibited.
0017	NO TELEFILE LABE	Telefile could not be recognized.
0022	AUDIO PLL UNLOCK	Audio clock generator PLL is not locked to reference video signal.
0030	NO SDI INPUT	When the optional HKSR-101 is installed, there is no valid input to the selected VIDEO I/O connector.
0032	INVALID SDI DATA	SDI input signal data are invalid.
0034	SDI A-B PHASE NG	Signals input to HD SDI IN A and B connectors are out of phase.
0036	SDI FMT MISMATCH	Format of signals input to HD SDI IN A and B connectors does not match system setting.
0037	SDI I/P MISMATCH	I/P of signals input to HD SDI IN A and B connectors do not match system setting.
004F	AUDIO DSP UNLOCK	Audio signal processing circuitry is not operating.
0050	NO PB RF	Playback head is not reading digital data from tape.
0051	BAD CH CONDITION	Playback signal quality is bad.
0060	LOST LOCK	Capstan servo lock was lost during playback or recording.
0067	CASSETTE REC INHI	The cassette is record-protected.

4. Audio Delay

To synchronize an audio signal externally recorded together with video signal output from the camera, appropriate delay shown in the table below is required for phase alignment between video and audio.

The values shown in the Code column are recorded as Metadata.

Sample No. 61 Audio Delay					
IMAGE INVERT				Video format	
OFF		ON			
Number of frames	Code (HEX)	Number of frames	Code (HEX)		
2	20	3	30	1080/23.98PsF 4:4:4	1080/23.98PsF 4:2:2
3	30	3	40	1080/S23.98PsF 4:4:4	1080/S23.98PsF 4:2:2
2	20	3	30	1080/24PsF 4:4:4	1080/24PsF 4:2:2
3	30	3	40	1080/S24PsF 4:4:4	1080/S24PsF 4:2:2
2	20	3	30	1080/25PsF 4:4:4	1080/25PsF 4:2:2

Sample No. 61 Audio Delay							
IMAGE INVERT				Video format			
OFF		ON					
Number of frames	Code (HEX)	Number of frames	Code (HEX)				
3	30	3	40	1080/S25PsF 4:4:4		1080/S25PsF 4:2:2	
2	20	3	30	1080/29.97PsF 4:4:4		1080/29.97PsF 4:2:2	
3	30	3	40	1080/S29.97PsF 4:4:4		1080/S29.97PsF 4:2:2	
3	30	3	40	1080/S30PsF 4:4:4		1080/S30PsF 4:2:2	
1	10	2	20		–	1080/50P 4:2:2	
2	20	2	30	1080/S50P 4:4:4		1080/S50P 4:2:2	
2	20	2	30	1080/S60P 4:4:4		1080/S60P 4:2:2	
2	20	2	30	1080/S59.94P 4:4:4		1080/S59.94P 4:2:2	
0.5	05	1	10	1080/50I 4:4:4		1080/50I 4:2:2	
0.5	05	1	10	1080/S59.94I 4:4:4		1080/59.94I 4:2:2	

The delay amount (from shot until output) of video varies depending on the video format. For more information, see “*Lip Sync Compensation*” on page 124.

When audio is directly connected to the interface box of the camera, the phase is automatically adjusted and embedded in the SDI signal output.

Warning/Error Messages

If battery power is low or a problem occurs at power on or during operation, a warning is given by an indicator flashing or various alarm indications.

Viewfinder screen		Subdisplay	RUN indicator	Meaning
Basic status display (page 47)	Message			
BATT 12 V flashing		BATT 12 V flashing	Flashing	Voltage of the 12 V power becomes low, reaching the specified NEAR END value.
BATT 12 V quick flashing		BATT 12 V quick flashing	Quick flashing	Voltage of the 12 V power becomes too low, reaching the specified END value.
BATT 24 V flashing		BATT 24 V flashing	Flashing	Voltage of the 24 V power becomes low, reaching the specified NEAR END value.
BATT 24 V quick flashing		BATT 24 V quick flashing	Quick flashing	Voltage of the 24 V power becomes too low, reaching the specified END value.
	TEMPERATURE CARE			Temperature inside the camera raises.
	TEMPERATURE WARNING			Temperature inside the camera raises to the limit.
	SHUTDOWN CAMERA			The camera must be turned off for safety.
	OHB/SIDE FAN NG!			The fan near the CCD or the fan near the side panel stops.
	PS FAN NG!			The fan near the power unit stops.
CAM?	OHB NG!			Abnormality of the CCD unit
CAM?	AD BOARD NG!			Abnormality of the AD board
CAM?	DPR BOARD NG!			Abnormality of the DPR board
CAM?	VDA BOARD NG!			Abnormality of the VDA board
CAM?	TR BOARD NG!			Abnormality of the TR board
CAM?	AT BOARD NG!			Abnormality of the AT board
	IF BOX NG!			Abnormality of the interface box
	OPT CA NG!			Abnormality of the CA-F101
	UNKNOWN RECORDER			An unknown recorder is connected.
	VTR ALARM			Alarm occurs at the SRW-1.
	VTR WARNING			Warning occurs at the SRW-1.
	LASER SHUTDOWN!			The laser-module protection circuit has been activated with the CA-F101 mounted. For details, refer to the Operation Manual of the CA-F101.

Precautions

Use and Storage

Do not subject the unit to severe shocks

The internal mechanism may be damaged or the body warped.

After use

Always turn off the power.

Before storing the unit for a long period

Remove the battery pack.

Use and storage locations

Store in a level, ventilated place. Avoid using or storing the unit in the following places:

- Places subject to temperature extremes
- Very damp places
- Places subject to severe vibration
- Near strong magnetic fields
- In direct sunlight or close to heaters for extended periods

To prevent electromagnetic interference from portable communications devices

The use of portable telephones and other communications devices near this unit can result in malfunctions and interference with audio and video signals.

It is recommended that the portable communications devices near this unit be powered off.

Note on laser beams

Laser beams may damage the CCDs. If you shoot a scene that includes a laser beam, be careful not to let the laser beam be directed into the lens of the camera.

Condensation

If you move the camera from a very cold place to a warm place, or use it in a damp location, condensation may form on the lens or inside the camera.

The camera has no built-in condensation indicator. If you find condensation on the body or lens, switch the camera off and wait for the condensation to disappear for about one hour.

Phenomena Specific to CCD Image Sensors

The following phenomena that may appear in images are specific to CCD (Charge Coupled Device) image sensors. They do not indicate malfunctions.

White flecks

Although the CCD image sensors are produced with high-precision technologies, fine white flecks may be generated on the screen in rare cases, caused by cosmic rays.

This is related to the principle of CCD image sensors and is not a malfunction.

The white flecks especially tend to be seen

- when operating at a high environmental temperature
- when you have raised the master gain (sensitivity)

This product has a compensation function and the problem may be alleviated by automatic black balance adjustment (*see page 42*).

Smear

When an extremely bright object, such as a strong spotlight or flashlight, is being shot, vertical tails may be produced on the screen, or the image may be distorted.

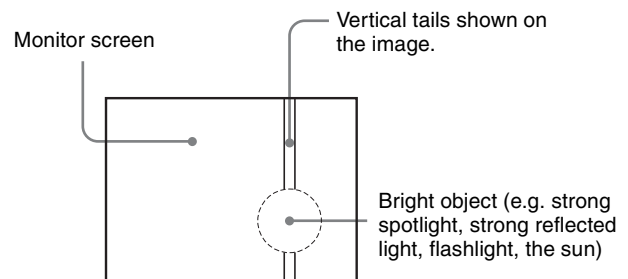

Aliasing

When fine patterns, stripes, or lines are shot, they may appear jagged or flicker.

To forcibly open the shutter

Should the shutter to control incoming light to the CCDs not open, immediately call Sony service personnel. If you wish to continue shooting for an emergency, you may open the shutter forcibly with the following operation: Use a flat-head screwdriver with external diameter of 3 mm or less and shaft length of 28 mm or greater.

- 1** Rotate the cap of the emergency shutter opening screw (*see page 12*) counterclockwise to remove.
- 2** Insert the screwdriver into the hole, align the top blade with the slot of the screw head, then turn the screw clockwise until it clicks.

The shutter opens.

About a “Memory Stick”

What is “Memory Stick”?

“Memory Stick” is a new compact, portable and versatile IC (Integrated Circuit) recording medium with a data capacity that exceeds a floppy disk. “Memory Stick” is specially designed for exchanging and sharing digital data among “Memory Stick” compatible products. Because it is removable, “Memory Stick” can also be used for external data storage.

“Memory Stick” media are available in three sizes: standard size, compact “Memory Stick Duo” size, and the smallest “Memory Stick Micro” (“M2”¹⁾) size. Once attached to a Memory Stick Duo adapter, a “Memory Stick Duo” is the same size as a standard “Memory Stick,” and as a result can be used with products requiring a standard “Memory Stick.” Also, once attached to a standard-size M2 adaptor, a “Memory Stick Micro” is the same size as a standard “Memory Stick,” and as a result can be used with products requiring a standard “Memory Stick.”

1) “M2” is an abbreviation for “Micro Memory Stick.”

Types of “Memory Stick”

“Memory Stick” is available in the following six types to meet various requirements in functions.

“Memory Stick”

Stores any type of data except copyright-protected data that requires the “MagicGate” copyright protection technology.

“MagicGate Memory Stick”

Equipped with the “MagicGate” copyright protection technology.

“Memory Stick” (“MagicGate”/High-Speed Transfer Compatible)

Equipped with “MagicGate” copyright protection technology and allows high-speed data transfer. This type of “Memory Stick” can be used with products requiring a “Memory Stick,” “MagicGate Memory Stick,” and “Memory Stick PRO.”¹⁾

1) Operation is not guaranteed for all of the compliant products. (Some products may not accept this type of “Memory Stick.”)

This camera is not compliant with high-speed data transfer with this type of “Memory Stick.”

“Memory Stick-ROM”

Stores pre-recorded, read-only data. You cannot record on “Memory Stick-ROM” or erase the pre-recorded data.

“Memory Stick” (with Memory Select Function)

Composed of multiple 128 MB memory units. The mechanical switch at the back of the “Memory Stick” allows you to select the memory unit to be used depending on usage. The memory units cannot be used simultaneously and continuously.

“Memory Stick PRO”

“Memory Stick” with “MagicGate” copyright protection technology, exclusive for “Memory Stick PRO”-compliant products.

Usable type of “Memory Stick”

You can use a “Memory Stick PRO” with this camera. The “Memory Stick PRO Duo” can also be used without using the Memory Stick Duo adaptor.

This camera is not compliant with Parallel mode of “Memory Stick.”

The camera operations have been checked using “Memory Stick PRO” media up to 8GB.

Operations checked with:

MSH-128
MSX-512S
MSX-M2GS
MSX-M4GS
MSX-M8GS

Note on data read/write speed

Data read/write speed may vary depending on the combination of the “Memory Stick” and “Memory Stick” compliant product you use.

What is “MagicGate”?

“MagicGate” is copyright protection technology that uses encryption technology.

Before using a “Memory Stick”

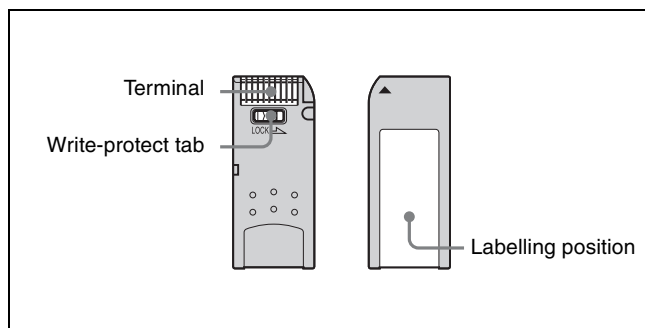

- When you set the “Memory Stick” erasure prevention switch to “LOCK,” data cannot be recorded, edited, or erased.
- Data may be damaged if:

- You remove the “Memory Stick” or turn off the unit while it is reading or writing data.
- You use the “Memory Stick” in a location subject to the effects of static electricity or electric noise.
- We recommend that you make a backup copy of important data that you record on the “Memory Stick”.

Notes

- Do not attach anything other than the supplied label to the “Memory Stick” labeling position.
- Attach the label so that it does not stick out beyond the labeling position.
- Carry and store the “Memory Stick” in its case.
- Do not touch the connector of the “Memory Stick” with anything, including your finger or metallic objects.
- Do not strike, bend, or drop the “Memory Stick”.
- Do not disassemble or modify the “Memory Stick”.
- Do not allow the “Memory Stick” to get wet.
- Do not use or store the “Memory Stick” in a location that is:
 - Extremely hot, such as in a car parked in the sun
 - Under direct sunlight
 - Very humid or subject to corrosive substances

- “Memory Stick”,  and “MagicGate Memory Stick” are trademarks of Sony Corporation.
- “Memory Stick Duo” and MEMORY STICK DUO are trademarks of Sony Corporation.
- “Memory Stick PRO” and MEMORY STICK PRO are trademarks of Sony Corporation.
- “Memory Stick PRO Duo” and MEMORY STICK PRO DUO are trademarks of Sony Corporation.
- “Memory Stick-ROM” and MEMORY STICK-ROM are trademarks of Sony Corporation.
- “MagicGate Memory Stick” is trademark of Sony Corporation.
- “MagicGate” and MAGICGATE are trademarks of Sony Corporation.

If the access indicator is lit in red

Data is being read from or written to the “Memory Stick”. At this time, do not shake the product or subject it to shock. Do not turn off the power of the product or remove the “Memory Stick.” This may damage the data.

Precautions

- To prevent data loss, make backups of data frequently. In no event will Sony be liable for any loss of data.
- Unauthorized recording may be contrary to the provisions of copyright law. When you use a “Memory Stick” that has been pre-recorded, be sure that the material has been recorded in accordance with copyright and other applicable laws.
- The “Memory Stick” application software may be modified or changed by Sony without prior notice.
- Note that there are certain restrictions on recording stage performances and other entertainment events, even if they are recorded for personal use only.

Specifications

Camera Head

General

Power requirements	DC 10.5 to 17 V
Power consumption	Approx. 56 W with 23.98 PsF (not including lens, viewfinder)
Operating temperature	0°C to +40°C (32°F to 104°F)
Storage temperature	-20°C to +60°C (-4°F to +140°F)
Mass	Approx. 5 kg (11 lb) (camera head only)

Imagers

Imagers	Super 35-mm RGB color CCD array
Method	1CCD
Aspect ratio	16:9
Effective resolution	R, G, B individually 1920 (horizontal) × 1080 (vertical)

Electrical characteristics

Sensitivity (at 2000 lx with 89.9% reflectivity)	T9 with 29.97 PsF (with <BASE SETTING>D-RANGE: NORMAL) T10 with 29.97 PsF (with <BASE SETTING>D-RANGE: EXTEND)
ISO sensitivity	ISO 340 (with <BASE SETTING>D-RANGE: NORMAL) ISO 450 (with <BASE SETTING>D-RANGE: EXTEND)
Registration	0.02% for total area (not including lens distortion)
Geometric distortion	Negligible (not including lens distortion)
Horizontal resolution	1000 TV lines (at center of screen) 5% or higher modulation

Optical system specifications

Lens mount	54-mm PL Mount
Flange focal length	52.00 mm (±0.15 mm adjustable)

Input/output connectors

DC IN	LEMO 8-pin male (1), DC 10.5 to 17 V, 20 to 30 V
DC OUT	12 V: 11-pin (1), DC 12 V, 4 A maximum 24 V: 3-pin (1), DC 24 V, 5.5 A maximum (The usable current may be limited depending on the load and input conditions.)
VF1, VF2	20-pin (1 each)
TEST OUT	BNC type (1), VBS/HD Y 75 ohms, 1.0 Vp-p
MONITOR OUT	HD SDI 4:2:2, BNC type (2), HD-SDI signal, BTA-S004A-compliant, 75 ohms, 0.8 Vp-p, 1.485 Gbps
GENLOCK IN	BNC type (1), 75 ohms, SMPTE 274M HD 3-level sync, 0.6 Vp-p
REMOTE	8-pin (1)
EXT I/O	LEMO 5-pin, female (1)
 (network)	RJ-45 type (1), 10BASE-T, 100BASE-TX

Supplied accessories

Interface box (1)
Assistant panel (1)
Assistant panel cable (1)
Assistant panel hanger (1)
+B4×8 screws (4)
Center handle (1)
L handle (1)
Riser plate (1)
Power cable connector (LEMO 8-pin) (1)
Operation manual (1)

Dimensions

With the L handle attached

Unit: mm (inches)

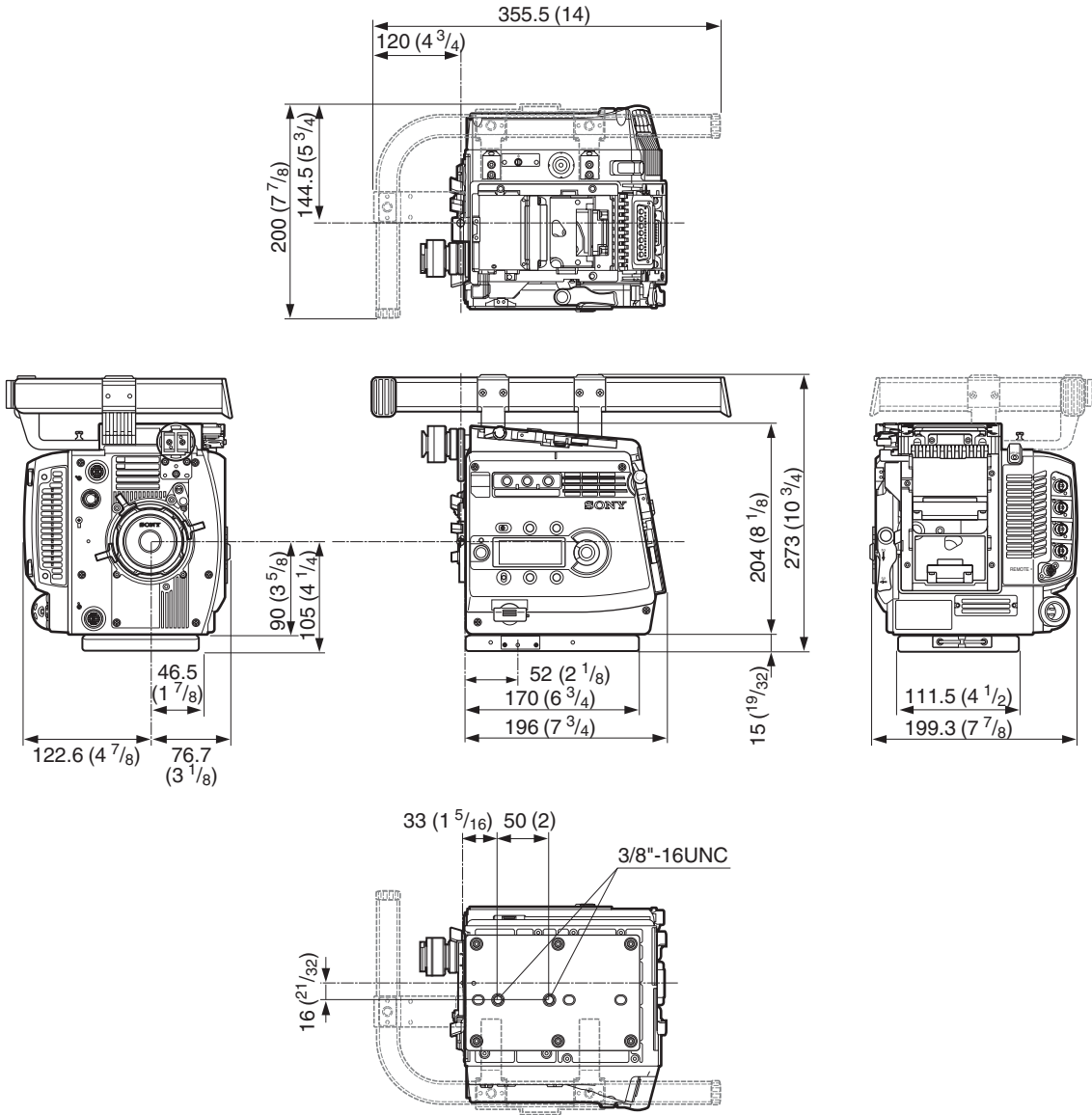

Interface Box (Supplied)

General

Power requirements	DC 10.5 to 17 V
Operating temperature	0°C to +40°C (32°F to 104°F)
Storage temperature	−20°C to +60°C (−4°F to +140°F)
Dimensions	138 × 104 × 79 mm (5 ¹ / ₂ × 4 ¹ / ₈ × 3 ¹ / ₈ inches)
Mass	Approx. 560 g (1 lb 4 oz)

Note

Always verify that the unit is operating properly before use. SONY WILL NOT BE LIABLE FOR DAMAGES OF ANY KIND INCLUDING, BUT NOT LIMITED TO, COMPENSATION OR REIMBURSEMENT ON ACCOUNT OF THE LOSS OF PRESENT OR PROSPECTIVE PROFITS DUE TO FAILURE OF THIS UNIT, EITHER DURING THE WARRANTY PERIOD OR AFTER EXPIRATION OF THE WARRANTY, OR FOR ANY OTHER REASON WHATSOEVER.

Input/output connectors

AUDIO IN CH1, CH2	XLR 3-pin, female (1 each) AUDIO switch in MIC: −44 dBu, balanced AUDIO switch in LINE: +4 dBu, balanced Phantom +48V
DC IN	XLR type, 4-pin, male (1)
HD SDI OUT A/B	BNC type (1 each), Dual Link, HD-SDI signal, BTA-S004A-compliant, 75 ohms, 0.8 Vp-p, 1.485 Gbps

Optional Accessories

HD Electronic Viewfinder	HDVF-20A (2-inch type, monochrome) HDVF-C35W (3.5-inch type, color)
Optical Fiber Camera Adapter	CA-F101
Remote Control Unit	RM-B750
Master Setup Unit	MSU-900/950
“Memory Stick”	

Design and specifications are subject to change without notice.

Connector Pin Assignments

REMOTE (8-pin female)

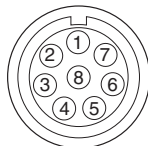

(External View)

No.	Signal	I/O	Specifications
1	TX (+)	OUT	SERIAL Data out
2	TX (-)	OUT	
3	RX (+)	IN	SERIAL Data in
4	RX (-)	IN	
5	TX-GND	—	GND for TX
6	UNREG	OUT	+10.5 to +17 V dc, 200mA (max)
7	UNREG-GND	—	GND for UNREG
8	VIDEO	OUT	75Ω, 1.0 Vp-p
	CHASSIS GND	—	CHASSIS GND

AUDIO IN CH-1/CH-2 (3-pin female)

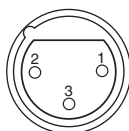

(External View)

No.	Signal	I/O	Specifications
1	AUDIO 1/2 (G)	—	-44 dBu (for MIC)/ +4 dBu (for LINE)
2	AUDIO 1/2 (X)	IN	
3	AUDIO 1/2 (Y)	IN	

(0 dBu=0.775 Vrms)

DC IN 10.5-17 V (4-pin male)

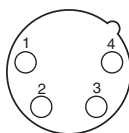

(External View)

No.	Signal	I/O	Specifications
1	GND	—	GND for DC (+)
2	NC		No connection
3	NC		No connection
4	DC (+)	IN	+10.5 to 17 V dc

VF 1/VF 2 (20-pin female)

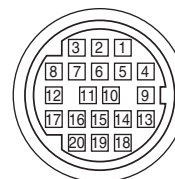

(External View)

No.	Signal	I/O	Specifications
1	S-DATA	IN/OUT	TTL level
2	NC		No connection
3	NC		No connection
4	SCK	OUT	TTL level
5	NC		No connection
6	NC		No connection
7	NC		No connection
8	G TALLY	OUT	ON: 5 V OFF: GND
9	NC		No connection
10	NC		No connection
11	NC		No connection
12	Y VIDEO	OUT	1.0 Vp-p, Zo=75Ω
13	VIDEO GND	—	GND for VIDEO
14	Pb VIDEO	OUT	±0.35 Vp-p, Zo=75Ω
15	Pr VIDEO	OUT	±0.35 Vp-p, Zo=75Ω
16	NC		No connection
17	R TALLY	OUT	ON: 5 V OFF: GND
18	NC		No connection
19	UNREG GND	—	GND for UNREG
20	UNREG	OUT	+10.5 V to +17 V

CTRL PANEL (14-pin female)

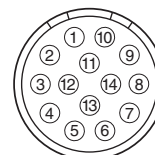

(External View)

No.	Signal	I/O	Specifications
1	SIN	OUT	VFD_I/F
2	SBUSY	IN	VFD_I/F
3	XRESET	OUT	VFD_I/F
4	RE_B	IN	
5	RE_A	IN	
6	IIC_DATA	IN/OUT	TTL level
7	IIC_CLK	OUT	TTL level
8	POWER	OUT	+7 V, 500 mA (MAX)

No.	Signal	I/O	Specifications
9	GND	—	
10	NC		
11	AUX1	IN	OPEN or +5 V: Normal GND: Active
12	AUX2	IN	OPEN or +5 V: Normal GND: Active
13	AUX3	IN	OPEN or +5 V: Normal GND: Active
14	NC		

DC IN (8-pin male)

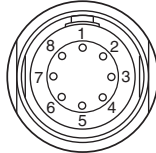

(External View)

No.	Signal	I/O	Specifications
1	UNREG_GND	—	GND for +12 V
2	UNREG_GND	—	GND for +12 V
3	UNREG_GND (24 V)	—	GND for +24 V
4	UNREG_24 V_IN	IN	+20 to +30 V
5	UNREG_12 V_IN	IN	+10.5 to +17 V
6	UNREG_12 V_IN	IN	+10.5 to +17 V
7	UNREG_12 V_IN	IN	+10.5 to +17 V
8	UNREG_GND	—	GND for +12 V

EXT I/O (5-pin female)

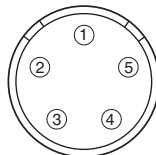

(External View)

No.	Signal	I/O	Specifications
1	EXT_CMD1_OUT	OUT	RS-232C
2	EXT_CMD0_OUT	OUT	
3	EXT_CMD1_IN	IN	
4	EXT_CMD0_IN	IN	
5	GND	—	

ETHERNET (Modular jack)

Conforming to IEEE 802.3u (100BASE-TX), IEEE802.3 (10BASE-T)

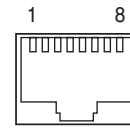

(External View)

No.	Signal	I/O	Specifications
1	TXD (+)	OUT	
2	TXD (-)	OUT	
3	RXD (+)	IN	
4	NC	—	
5	NC	—	
6	RXD (-)	IN	
7	NC	—	
8	NC	—	

DC OUT 12 V (11-pin female)

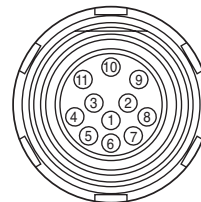

(External View)

No.	Signal	I/O	Specifications
1	NC		
2	NC		
3	NC		
4	NC		
5	NC		
6	NC		
7	NC		
8	NC		
9	UNREG_GND	—	
10	NC		
11	UNREG_12 V_OUT	OUT	+10.5 to +17 V dc 5.0 A (MAX)

DC OUT 24 V (3-pin female)

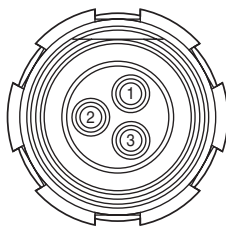

(External View)

No.	Signal	I/O	Specifications
1	UNREG_GND (24 V)	—	
2	UNREG_24 V_OUT	OUT	+20 to +30 V dc 5.0 A (MAX)
3	REC trigger	IN	OPEN or +5 V: Normal GND: Active

Color Space According to the COLOR SPACE Settings

Colorimetry

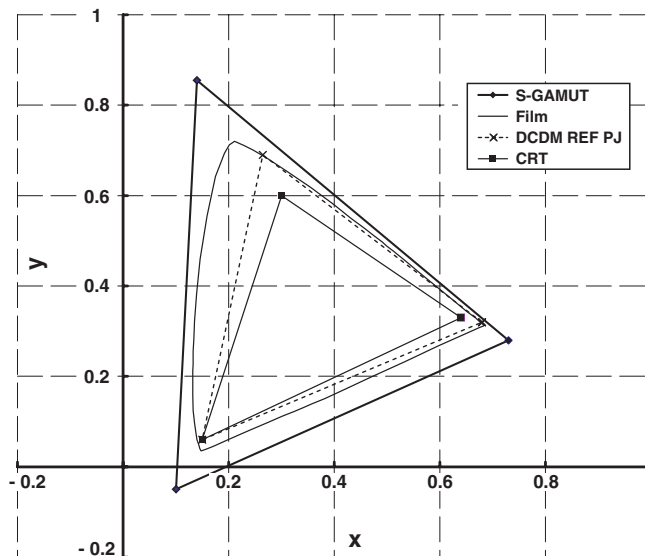

1. Virtual chromaticity points at S-GAMUT

The virtual color space at S-GAMUT is shown in the above chart. The virtual chromaticity points are as follows:

	x	y
R	0.73	0.28
G	0.14	0.855
B	0.1	-0.05

When converting the color space of a video source shot with this camera in S-GAMUT mode, use these virtual chromaticity points.

These chromaticity points are "virtual" because they do not represent the actual, accurate color space but are the calculated values for calculation of color space conversion. These virtual chromaticity points have been introduced because the actual color space cannot be represented as a triangle in this colorimetry.

A simple formula for conversion from the color space for S-GAMUT to that for conventional cameras (HDC-F950, HDW-F900R, etc.) is shown below:

$$\begin{bmatrix} R \\ G \\ B \end{bmatrix} = \begin{bmatrix} 1.306240 & -0.233075 & -0.073165 \\ -0.126851 & 1.178376 & -0.051526 \\ 0.000120 & -0.085649 & 1.085529 \end{bmatrix} \begin{bmatrix} R_w \\ G_w \\ B_w \end{bmatrix}$$

(Rw, Gw, Bw): RGB values for the original color space for S-GAMUT
 (R, G, B): Values after being converted to the color space for conventional cameras

2. Color space for film

The color space for film shown in the above chart represents measurements from VISION Premier Film EK 2393.

3. Color space for F900 mode

The color space for conventional cameras (HDC-F950, HDW-F900R, etc.) is wider than that for DCDM REF PJ but narrower than that for film.

Lip Sync Compensation

Compensation (Lip Sync compensation) for the delay of video relative to audio may be necessary, depending on the video format and system configuration.

Amount of delay of video relative to audio

The amount of delay of video relative to audio depends the video format and the status of the image-inversion (IMAGE INVERT) function (*see page 58*) as follows:

Unit: frames per second

Video format	IMAGE INVERT	
	OFF	ON
59.94i	0.5	1
50i	0.5	1
50P	1	2
29.97PsF	2	3
25PsF	2	3
23.98PsF	2	3

System in which automatic compensation is made

When a microphone(s) connected via the AUDIO IN connector(s) on the interface box mounted on the camera is used, the camera automatically performs the necessary compensation.

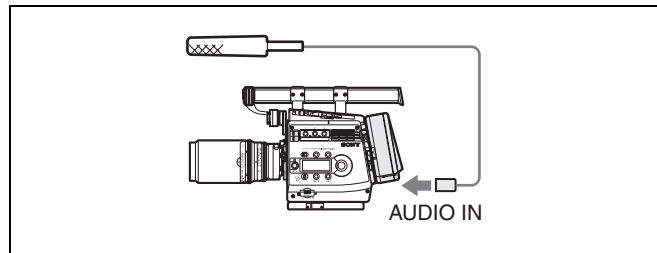

Systems for which manual compensation is required

For the following systems, Lip Sync compensation must be performed manually.

The compensation is to be adjusted according to the amount of delay shown above.

When using a microphone(s) connected via the AUDIO INPUT connector(s) on the SRW-1 mounted on the camera body

Adjust the amount of compensation on the SRW-1.

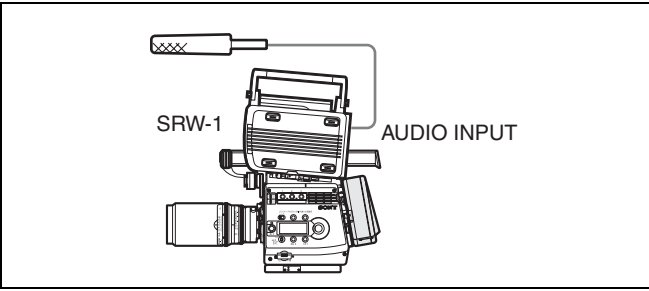

When using a microphone(s) connected via the AUDIO INPUT connector(s) on the SRW-1 with the SRPC-1 connected to the camera body via cables
 Adjust the amount of compensation on the SRW-1.

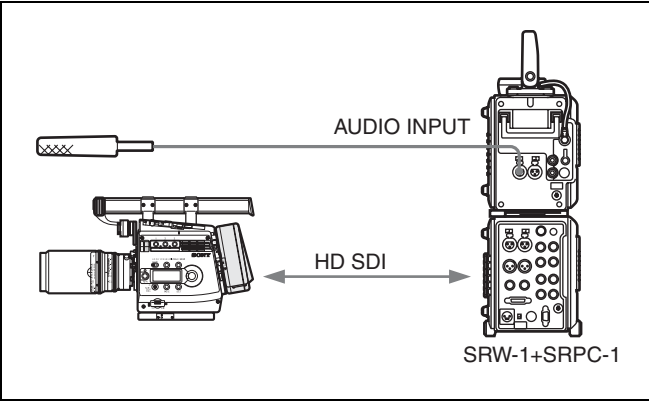

For timecode-synchronized audio recording on a separate digital audio recorder
 Connect a delay box to the digital audio recorder and adjust the amount of compensation on the box.

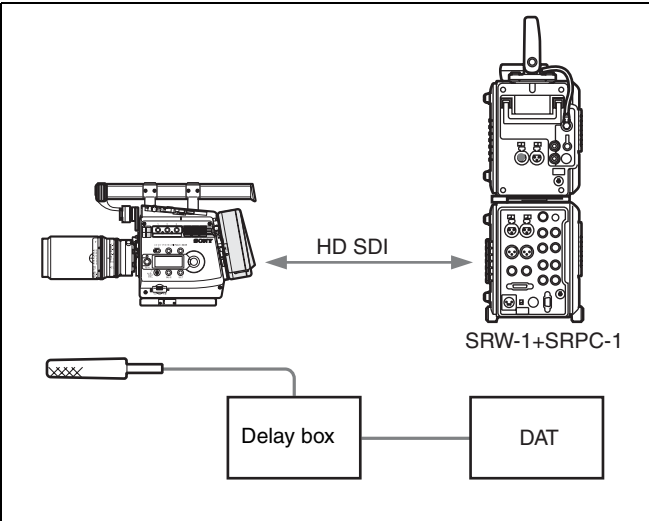

Index

A

ABNORMAL display 48
AC power 27
accessory clamp lever 19
accessory mount lever 19
Accessory pockets 13
Accessory receptacles 12
Aliasing 115
ALL menu 60
ANGLE 55
Angle Compensation mode 34, 55
Assignable buttons 14, 39
Assignable switch 15, 39
AUDIO IN CH-1/CH-2 connectors 17
Audio input selection switches 17
AUTO BLK BAL switch 15, 42
AUTO SETUP 43, 78
AUTO WHITE 43
Automatic black balance 42
Automatic white balance 42
AUX connector 17

B

BASE SETTING 31, 78
Basic Operation Modes 30
BATT ALARM SET 80
BATTERY ALARM 52, 70
battery pack 28
BKP-L551 28
BLACK GAMMA 72
BLACK SHADING 79
BOARD STATUS 89
Box cursor 51
BP-GL95 28
BRIDGE 104
Bridge mode 103
brightness of the subdisplay 40
built-in clock 28

C

CA-F101 22, 27
CAM BARS 46
CAM POWER switch 13
CAMERA connector 17
CANCEL/STATUS button 15, 32
center handle 26
Center marker 49
CHAR/MARK MIX 51, 65
Cine mode 30
COLOR 44
COLOR SPACE 123

COLOR SPACE 31
color temperature 36
COMP MODE 55
Condensation 115
CONTENTS page 62
CONTINUOUS 54
Continuous mode 33, 54
CONTROL PANEL connector 12
Custom mode 30
CvpFileEditor 58

D

Data Change mode (subdisplay) 32
DATE 28, 80
DAYLIGHT 37
DC IN connector 13, 17
DC OUT 12V connector 14
DC OUT 24V connector 14
DETAIL 1 73
DETAIL 2 74
DIAGNOSIS menu 61, 89
DOWN CONVERTER 80
D-RANGE 31

E

EDIT FUNCTION 90
Electrical characteristics 118
electrical gain 37
ETHER I/F CONF 84, 104
EXT I/O connector 14

F

Fan Operation mode 38
FILE menu 61, 85
FILE PRESET 88
flange focal length 23
Flange focal length adjustment screw 12
Focus reference mark 14, 15
FORMAT MEMORY 36
FRAME 59
FRAME RATE 55
frame rate 34
FUNCTION display 49

G

GAIN 55
gain 36
GAIN ASSIGN 54, 69
Gain Compensation mode 34, 55
GAMMA 56, 72
GAMMA MARK 46
GAMMA MARK SETTING 46
GENLOCK IN connector 16

H

HD Portable Digital Recorder 21
HD-BAR (VF MONI) 46
HD-SDI A/B connectors 17
Hyper Gamma 57

I

IMAGE INVERT 58
image-inversion function 58
Imager 118
Interface Box 17
IP ADDR SET 84, 104

K

KNEE 73

L

L handle 13, 26
LEGACY 102
LENS FILE 70, 87, 98
Lens files 93
lens files 37
Lens fixing lever 12
Lens mount cap 12
Level vial 13
Lip Sync compensation 124
LOCK switch 14, 32
lock-release knob 19

M

MAINTENANCE menu 60, 78
MARKER DISPLAY 50
MARKER SETTING 50, 52, 66
MCS 104
Measure hook 14
Memory Stick section 15
MENU SEL/ENTER dial 16, 32
MIX TYPE 45
MIX 45
MONI GAMMA ENABLE 45
MONI HD-SDI 44
monitor gamma 45
MONITOR OUT HD SDI connectors 16
MONITOR OUTPUT 44, 66
MSU-900/950 103
Multi (MCS) mode 103
MULTI MATRIX 75

N

ND offset 100
network connector 14
NETWORK menu 61, 84
NETWORK RESET 84

NOISE SUPPRESS 76
Noise Suppression 77

O

OHB FILE 87, 88, 100
OHB MATRIX 79
OPERATION menu 60, 64
OPERATOR FILE 56, 70, 85, 97
Operator file 93
Optical system specifications 118
OTHERS 1 46, 58, 82
OTHERS 2 83
OUTPUT FORMAT 59, 80

P

PAGE button 15, 32
PAGE SELECT 41, 69
PAINT menu 60, 71
PB MIX SETTING 45, 67
PB MIX 45
PB/MONI GAMMA 44, 67
PB 45
Phenomena Specific to CCD Image
Sensors 115
PLD VERSION 89
Power indicators 13
POWER SAVE 80

R

RAMP 35, 76
REFERENCE 86, 99
Reference file 94
REMOTE connector 16
reset a specific item of the reference file
101
RM VIDEO 44
RM-B150 54
RM-B750 102
ROM VERSION 89
RUN button 14
RUN indicator 16, 114

S

safety release tab 20
Safety zone marker 50
SATURATION 72
SCAN 59
SCENE FILE 77, 86, 98
Scene files 93
SD-BAR 46
SELECT FPS 59
SET button 15, 32
SHOOT MODE 31
SHUTTER ASSIGN 34, 68
Shutter emergency opening screw 12

SHUTTER/FPS 54, 76
SIGNAL 59
SKIN DETAIL 74
S-LOG 57
Smear 115
SRW-1 21
STANDARD 99
Standard Gamma 56
status indications 47
STEP 54
Step mode 33, 54
Subdisplay 15
SUBDISPLAY 1 36, 68
SUBDISPLAY 2 41, 68
SW STATUS 71
SWITCH ASSIGN 53, 69
SYSTEM STATUS 89

T

tape remaining 38
TEST OUT 44
TEST OUT connector 16
time code 38
TOP MENU screen 62
tripod 25
Tripod receptacles 15
TUNGSTEN 37

U

USER GAMMA 58, 86, 100
User Gamma 57
USER MATRIX 75
USER menu 60
USER MENU CUSTOMIZE menu 60,
90
User-Gamma file 94

V

VF DETAIL 51, 66
VF DISPLAY 48, 64
VF MENU/DISPLAY button 15, 32
VF1 connector 12
VF2 connector 12
video format 35, 59
VIDEO LEVEL 71
Viewfinder shoe 12

W

white balance memory 37
WHITE CLIP 73
White flecks 115
WHITE SHADING 79
WIPE 46
Wrench box 16

Z

ZEBRA 51, 66
OHB file 94

Symbols

'!' IND 49, 65

Numerics

5600K 37
700PTP SETTING 84, 104





The material contained in this manual consists of information that is the property of Sony Corporation and is intended solely for use by the purchasers of the equipment described in this manual.

Sony Corporation expressly prohibits the duplication of any portion of this manual or the use thereof for any purpose other than the operation or maintenance of the equipment described in this manual without the express written permission of Sony Corporation.

For Customer in China

根据中华人民共和国信息产业部第39号令《电子信息产品污染控制管理办法》及标准中要求的“有毒有害物质或元素名称及含量”等信息，本产品相关信息请参考以下链接：

<http://pro.sony.com.cn>

制造商：索尼公司

原产地：日本

总经销商：索尼（中国）有限公司

进口商地址：北京市朝阳区东三环北路霞光里18号佳程大厦A座25层

出版日期：2008年11月

Sony Corporation

<http://www.sony.net/>

F35 (SY)
4-000-998-03(1)

Printed on recycled paper.

Printed in Japan
2008.11.13
© 2008