

SONY®

HD PORTABLE DIGITAL RECORDER

SRW-1

HD VIDEO PROCESSOR

SRPC-1

OPTICAL INTERFACE UNIT

HKSR-101

PICTURE CACHE BOARD

HKSR-102

HDCAM SR™

 **Tele-File** 

OPERATION MANUAL
1st Edition (Revised 3)

English

WARNING

To prevent fire or shock hazard, do not expose the unit to rain or moisture.

To avoid electrical shock, do not open the cabinet. Refer servicing to qualified personnel only.

For the customers in the USA

This equipment has been tested and found to comply with the limits for a Class A digital device, pursuant to Part 15 of the FCC Rules. These limits are designed to provide reasonable protection against harmful interference when the equipment is operated in a commercial environment. This equipment generates, uses, and can radiate radio frequency energy and, if not installed and used in accordance with the instruction manual, may cause harmful interference to radio communications. Operation of this equipment in a residential area is likely to cause harmful interference in which case the user will be required to correct the interference at his own expense.

You are cautioned that any changes or modifications not expressly approved in this manual could void your authority to operate this equipment.

The shielded interface cable recommended in this manual must be used with this equipment in order to comply with the limits for a digital device pursuant to Subpart B of Part 15 of FCC Rules.

For the customers in the USA and Canada RECYCLING LITHIUM-ION BATTERIES

Lithium-ion batteries are recyclable. You can help preserve our environment by returning your used rechargeable batteries to the collection and recycling location nearest you.



For more information regarding recycling of rechargeable batteries, call toll free 1-800-822-8837, or visit <http://www.rbc.org/>

Caution: Do not handle damaged or leaking lithium-ion batteries.

For the customers in Europe

This product with the CE marking complies with the EMC Directive (89/336/EEC) issued by the Commission of the European Community.

Compliance with these directives implies conformity to the following European standards:

- EN55103-1: Electromagnetic Interference (Emission)
- EN55103-2: Electromagnetic Susceptibility (Immunity)

This product is intended for use in the following

Electromagnetic Environment(s):

E1 (residential), E2 (commercial and light industrial), E3 (urban outdoors) and E4 (controlled EMC environment, ex. TV studio).

For HKSR-101 only

CLASS 1 LASER PRODUCT
LASER KLASSE 1
LUOKAN 1 LASERLAITE
KLASS 1 LASERAPPARAT

This Optical Interface Unit is classified as a CLASS 1 LASER PRODUCT.

Laser diode properties

Wave length: 1310±20 nm
Emission duration: Continuous
Laser output power: 10 mW (max.)

Laserdiode data

Bølgelængde: 1310±20 nm
Strålingsvarighed: Kontinuerlig
Lasereffekt: 10 mW (max.)

Laserdiodens egenskaper

Våglängd: 1310±20 nm
Strålningsstid: utan avbrott
Laserut effekt: 10 mW (max.)

Laserdiodens egenskaper

Bølgelængde: 1310±20 nm
Emisjonslengde: Kontinuerlig
Laser utgangseffekt: 10 mW (max.)

CAUTION

The use of optical instruments with this product will increase eye hazard.

CAUTION

Use of controls or adjustments or performance of procedures other than those specified herein may result in hazardous radiation exposure.

This device complies with part 15 of the FCC Rules. Operation is subject to the following two conditions: (1) this device may not cause harmful interference, and (2) this device must accept any interference received, including interference that may cause undesired operation.

For customers in Canada

This Class A digital apparatus complies with Canadian ICES-003.

Voor de Klanten in Nederland

Gooi de batterij niet weg maar lever deze in als klein chemisch afval (KCA).



VORSICHT

Um Feuergefahr und die Gefahr eines elektrischen Schlages zu vermeiden, darf das Gerät weder Regen noch Feuchtigkeit ausgesetzt werden.

Um einen elektrischen Schlag zu vermeiden, darf das Gehäuse nicht geöffnet werden. Überlassen Sie Wartungsarbeiten stets nur qualifiziertem Fachpersonal.

Für Kunden in Europa

Dieses Produkt besitzt die CE-Kennzeichnung und erfüllt die EMV-Richtlinie (89/336/EWG) der EG-Kommission.

Angewandte Normen:

- EN55103-1: Elektromagnetische Verträglichkeit (Störaussendung)
- EN55103-2: Elektromagnetische Verträglichkeit (Störfestigkeit),

für die folgenden elektromagnetischen Umgebungen:

E1 (Wohnbereich), E2 (kommerzieller und in beschränktem Maße industrieller Bereich), E3 (Stadtbereich im Freien) und E4 (kontrollierter EMV-Bereich, z.B. Fernsehstudio).

Für Kunden in Deutschland

Entsorgungshinweis: Bitte werfen Sie nur entladene Batterien in die Sammelboxen beim Handel oder den Kommunen.

Entladen sind Batterien in der Regel dann, wenn das Gerät abschaltet und signalisiert "Batterie leer" oder nach längerer Gebrauchsdauer der Batterien "nicht mehr einwandfrei funktioniert". Um sicherzugehen, kleben Sie die Batteriepole z.B. mit einem Klebestreifen ab oder geben Sie die Batterien einzeln in einen Plastikbeutel.

Daten der Laserdiode (Nur für HKSR-101)

Wellenlänge: 1310±20 nm

Emissionsdauer: Kontinuierlich

Laser-Ausgangsleistung: 10 mW (max.)

AVERTISSEMENT

Afin d'éviter tout risque d'incendie ou d'électrocution, ne pas exposer cet appareil à la pluie ou à l'humidité.

Afin d'écartier tout risque d'électrocution, garder le coffret fermé. Ne confier l'entretien de l'appareil qu'à un personnel qualifié.

Pour les utilisateurs aux Etats-Unis et au Canada. RECYCLAGE DES ACCUMULATEURS AUX IONS DE LITHIUM

Les accumulateurs aux ions de lithium sont recyclables.

Vous pouvez contribuer à préserver l'environnement en rapportant les piles usées dans un point de collection et recyclage le plus proche.



Pour plus d'informations sur le recyclage des accumulateurs, téléphonez au numéro gratuit 1-800-822-8837 (Etats-Unis et Canada uniquement), ou visitez <http://www.rbrc.org/>

Avertissement: Ne pas utiliser des accumulateurs aux ions de lithium qui sont endommagés ou qui fuient.

Pour les utilisateurs au Canada (HKSR-101 seulement)

Cet appareil numérique de la classe A est conforme à la norme NMB-003 du Canada.

Pour les clients européens

Ce produit portant la marque CE est conforme à la Directive sur la compatibilité électromagnétique (EMC) (89/336/CEE) émise par la Commission de la Communauté européenne. La conformité à cette directive implique la conformité aux normes européennes suivantes:

- EN55103-1: Interférences électromagnétiques (émission)
- EN55103-2: Sensibilité électromagnétique (immunité)

Ce produit est prévu pour être utilisé dans les environnements électromagnétiques suivants:

E1 (résidentiel), E2 (commercial et industrie légère), E3 (urbain extérieur) et E4 (environnement EMC contrôlé, ex. studio de télévision).

For the customers in Taiwan only



廢電池請回收

Table of Contents

Chapter 1 Overview

1-1 Features	7
1-1-1 Principal Features	7
1-1-2 HDCAM-SR Format.....	8
1-2 System Configuration	10

Chapter 2 Names and Functions of Parts

2-1 SRW-1	11
2-1-1 Principal Sections	11
2-1-2 Control Panel	12
2-1-3 Display	15
2-1-4 Connector Panel.....	17
2-2 SRPC-1	19

Chapter 3 Preparations

3-1 Assembly	23
3-1-1 Joining the SRW-1 and SRPC-1.....	23
3-1-2 Using the Control Panel Extension Cable	25
3-2 Connections	27
3-2-1 Connections for Recording	27
3-2-2 Connections for Playback	29
3-3 About Reference Sync Signals	30
3-3-1 Reference Signals for Video Output Signals.....	30
3-3-2 Connecting Reference Signals (Examples for When External Sync Is Required)	31
3-4 Power Supply Preparations	34
3-4-1 Using a Battery Pack	34
3-4-2 Using AC Power	34
3-4-3 Powering On and Off.....	35
3-4-4 Checking the Power and Voltage	35
3-5 Display Settings	36
3-6 Superimposed Text Information	36
3-7 Handling Cassettes	38
3-7-1 Usable Cassettes	38
3-7-2 Inserting and Ejecting Cassettes	38
3-7-3 Preventing Accidental Erasure	39
3-8 Power Saving Mode	40

Chapter 4 Menu Settings

4-1 Basic Menu Operations	41
4-1-1 Displaying Menus	41
4-1-2 Changing Menu Settings.....	41
4-2 TC Setup Menu	43
4-3 VIDEO Setup Menu	47
4-4 AUDIO Setup Menu	48
4-5 SYSTEM Setup Menu	50

Chapter 5 Recording and Playback

5-1 Signal Format Settings	55
5-1-1 Selecting the System Signal Format	55
5-1-2 TeleFile Recording	57
5-2 Recording Preparations and Operations	58
5-2-1 Selecting the Video Input To Record (When Optional HKSR-101 Is Installed) 58	
5-2-2 Selecting Signals to Output to the HD Monitor	58
5-2-3 Making Audio Signal Settings.....	59
5-2-4 Setting Recording Audio Levels.....	60
5-2-5 Making Timecode and User Bits Settings.....	60
5-2-6 Recording Operations	62
5-3 Playback Preparations and Operations 64	
5-3-1 Selecting the Conversion Mode of the Downconverter.....	64
5-3-2 Making Audio Monitor Signal Settings. 64	
5-3-3 Adjusting Playback Audio Levels	64
5-3-4 Selecting Time Data to Display During Playback	64
5-3-5 Playback Operations	65
5-4 SELECT FPS Function (Selectable Recording Frame Rate) (When Optional HKSR-102 Is Installed)	66
5-4-1 Overview.....	66
5-4-2 Setting the SELECT FPS.....	67

Appendixes

Maintenance and Inspections	69
--	-----------

Head Cleaning	69
Handling the Optical-Fiber Connector (When Optional HKSR-101 Is Installed)	69
Condensation	69
Specifications	70
General	70
Digital Video System	70
Digital Audio System	70
Input Connectors	70
Output Connectors.....	71
Other Connectors.....	71
Supplied Accessories.....	71
Optional Accessories.....	71
Recommended Accessories.....	72
Error Messages and Warning Messages	72
About Error Messages	72
About Warning Messages	75
Warning System	78
Attaching the Shoulder Belt	80
Troubleshooting.....	81
What Is Dual Link?	85
Index.....	86

1-1 Features

The SRW-1 is an HDCAM-SR¹⁾ format high-definition portable digital recorder. It is used together with the SRPC-1 high-definition video processor.

1) HDCAM-SR is a trademark of Sony Corporation.

1-1-1 Principal Features

The SRW-1 and SRPC-1 have the following features.

High-quality digital recording

The SRW-1 uses a Y/Pb/Pr component system and an RGB component system to record video signals. An AES/EBU format with a wide dynamic range is used for 12-channel audio recording. Powerful error correction and error concealment circuits unique to HDCAM-SR are used in digital signal processing. Accurate and stable video signal output can be obtained by adjusting the internal video signal processor.

Recording and playback modes

You can select from the following recording and playback modes.

1080 × 1920 (progressive): 23.98PsF, 24PsF, 25PsF, 29.97PsF, 50P, 59.94P

1080 × 1920 (interlaced): 59.94i / 50i

720 × 1280 (progressive): 50P/59.94P

Double-speed recording

Drum rotation and tape transport can be increased to double speed for high-speed data transfers, allowing twice as much data to be recorded in the same time. 4:4:4 RGB video can be recorded for even higher quality.

The output of two camera systems can be recorded simultaneously on a single tape as 4:2:2 DUAL STREAM. The 1080 50P/59.94P format signal can also be recorded.

Input interface

The input interface is based on the HD SDI (HD Serial Digital Interface) format compliant to BTA S-004B/005B/006B (SMPTE 291M/292M/299M) and ARIB STD B-4. One component video signal, 12 channels of digital audio signals, and a timecode signal are time-division multiplexed and carried along a single (or a couple of) coaxial cable(s) with BNC-type connectors. These signals are separated and converted to parallel data. Audio signals to record can be switched among the following three: signals multiplexed into the HD SDI signals described above, audio signals from the AES/EBU digital interface, and analog audio signals from microphones or other analog audio devices.

Output interface

Component video signals are converted into serial data, multiplexed with audio signals and timecode, and output in the HD SDI format. SD SDI output can also be obtained by using the internal HD/SD downconverter. In addition to digital audio signals multiplexed into the HD SDI signals described above, audio is output from the AES/EBU digital interface, and analog audio is output after D/A conversion.

Transmission over optical-fiber cable (with optional HKSR-101 installed)

When the optional HKSR-101 Optical Interface Unit is installed, this unit can be connected to an HDC-F950 HD Color Video Camera by optical-fiber cable. A single optical-fiber cable can receive HD 4:2:2 component video signals or HD 4:4:4 RGB video signals, while simultaneously transmitting HD 4:2:2 component video return signals to the camera. Audio signals and

control signals are multiplexed into video signals transmitted over optical-fiber cable.

Note

Power cannot be supplied to a camera from this unit by optical-fiber cable.

SELECT FPS function (with optional HKSR-102 installed)

When the optional HKSR-102 picture cache board is installed, you can specify frame rates in units of 1 fps (SELECT FPS) and perform slow or quick shooting. The number of frames can be specified over the ranges 1 to 60 fps (4:2:2 format) or 1 to 30 fps (4:4:4 format).

Format conversion

This unit is capable of the following format conversion for output to monitors.

- Color space conversion (4:4:4 RGB → 4:2:2 YPbPr)
- 2-3 pulldown (4:2:2 23.98PsF → 4:2:2 59.94i)
- Downconverter (1080i → SD 525i/625i)

Removable control panel

The control panel is independent of the SRW-1 (VTR main unit), allowing it to be installed in the most convenient location in your operating environment. It can be held in the hand and operated like a remote controller.

Internal timecode generator and reader

The internal timecode generator allows you to record timecode (LTC¹) and user bit data²) along with the video and audio signals. The internal timecode reader reads the recorded timecode (LTC and user bit data) during playback.

1) LTC (Longitudinal Time Code):

Timecode recorded on longitudinal tracks of the tape. It may not be read correctly when the tape speed is very slow or when the tape speed changes suddenly.

2) User bit data:

Eight-digit hexadecimal numbers which can be recorded as auxiliary information during recording of timecode.

Independent audio level adjustment

You can adjust audio levels independently while checking peaks on all 12 audio channels.

Self diagnostics

When an error occurs, the system performs self diagnostics and displays the cause.

1-1-2 HDCAM-SR Format

The HDCAM-SR format exploits advances in signal processing and magnetic recording technology to enable HD digital recording and playback with high image and sound quality, with functionality comparable to that of the HDCAM format.

- Highly efficient mild data compression based on the new MPEG-4 Studio Profile
- Powerful error correction system
- Highly reliable narrow track recoding and playback through high-performance, high-accuracy, drum-mounted heads.

These technologies allow extended high-definition recording times on HDCAM-SR cassettes of the same size as the HDCAM cassette: 40 minutes or more on S-size HDCAM-SR cassettes.

Digital signal processing

4:2:2 component video signals or 4:4:4 RGB signals obtained by quantization according to ITU-R709, SMPTE 274M, and BTA S-002B (SMPTE 260M) are compressed according to the MPEG-4 Studio Profile. Audio signals are processed uncompressed, according to the AES/EBU format.

Bit rate reduction encoder

Component video signal data is compressed to specified data rates by a process in which it is subjected to frame shuffling, DCT (discrete cosine transform) or DPCM (differential pulse code modulation), quantizing adjustment, and variable length word encoding. This process forms the core of the new MPEG-4 Studio Profile compression strategy. The process uses intra-frame compression for progressive image capture and intra-field compression for interlaced images.

ECC encoder

An outer ECC (error correction code) is interleaved with the compressed data, followed by inner ECC, ID data, and sync data. The error correction system uses standard Reed-Solomon codes.

Channel coding

Video and audio with the addition of ECC data are recorded in the form of serial data. The HDCAM-SR format uses a scrambled NRZI (Non-Return-to-Zero Inverted) channel coding system to ensure superior off-track and noise tolerance characteristics.

Playback signal processing

Digital playback signals are equalized by equalizer circuits and error corrected by powerful inner and outer ECC. This

process corrects most noise and dropout problems in the reproduced signal. Data that cannot be completely corrected in this way is corrected by error concealment circuits.

Tele-File ¹⁾ memory label system

The SRW-1 supports the Tele-File memory label system.

1) Tele-File:

A system in which non-contact memory ICs on the spines of cassettes allow you to record and read data about the material on the cassettes. Tele-File is a trademark of Sony Corporation.

1-2 System Configuration

The following figure shows a system configured around the SRW-1 and SRPC-1.

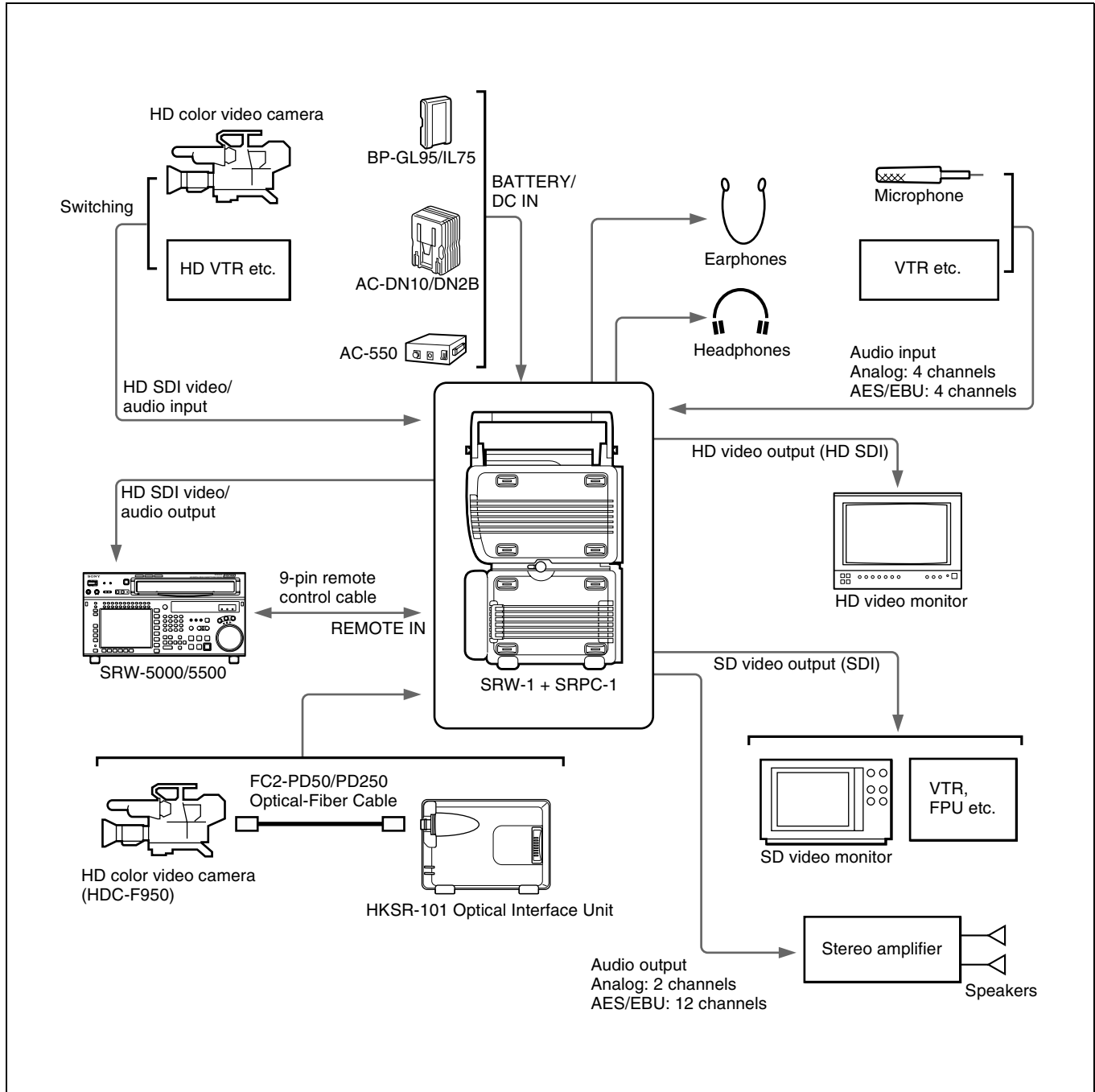

Names and Functions of Parts

Chapter 2

2-1 SRW-1

2-1-1 Principal Sections

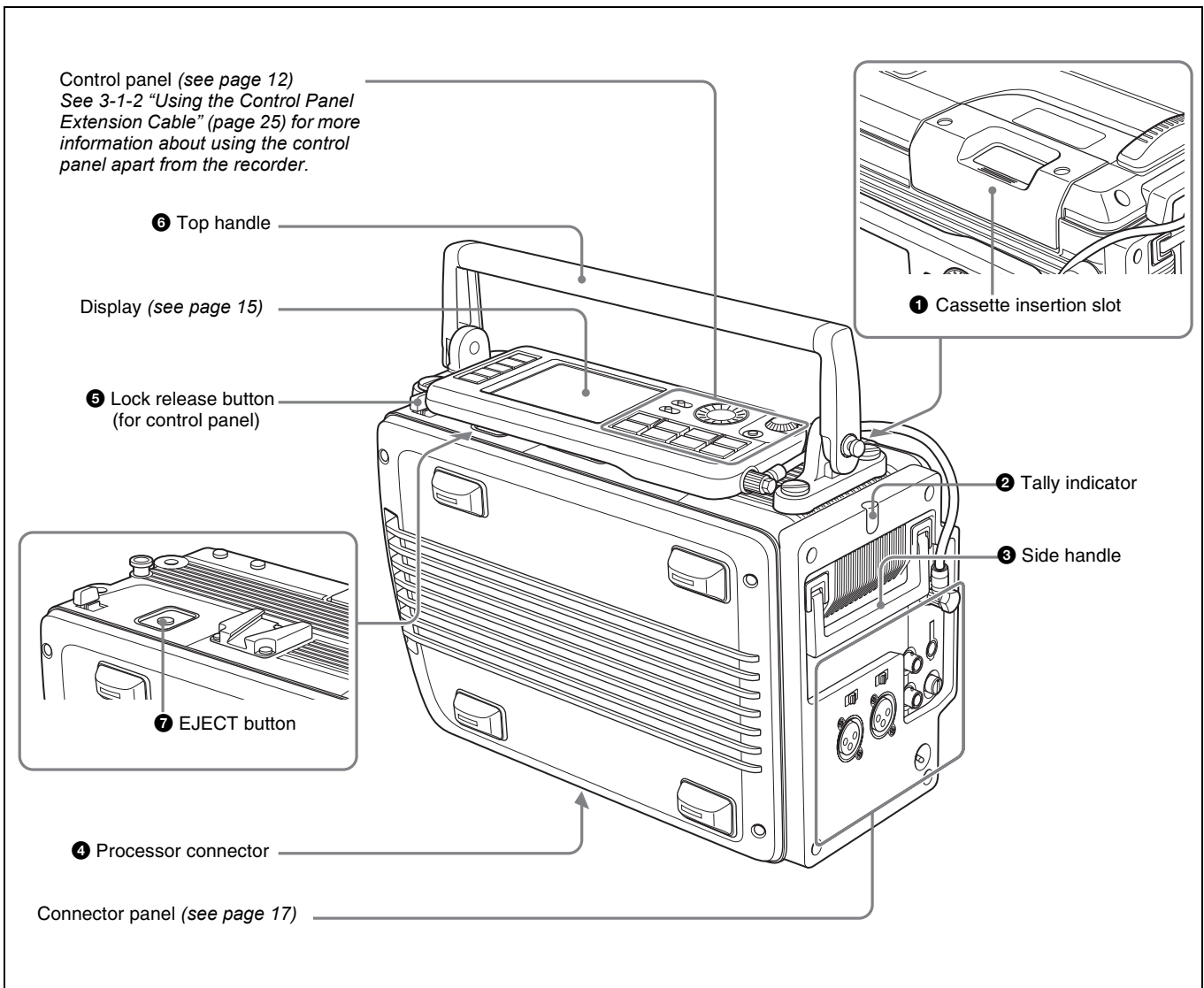

1 Cassette insertion slot

Insert cassettes.

For details, see 3-7-2 “Inserting and Ejecting Cassettes” (page 38).

2 Tally indicator

Lights during recording.

Flashes when errors have occurred (see “About Error Messages” (page 72)) or when warnings have occurred (see “About Warning Messages” (page 75)).

For more information about the tally indicator operation, see “Warning System” (page 78).

3 Side handle

When the top handle is removed, use this handle to join and separate the SRW-1 and SRPC-1.

4 Processor connector

Connect the SRPC-1 HD video processor.

5 Lock release button (for control panel)

When removing the control panel, use this button.

For more information about using this button, see 3-1-2 “Using the Control Panel Extension Cable” (page 25).

6 Top handle

Use to carry the SRW-1 or joined SRW-1/SRPC-1.

If you need to remove the top handle from the SRW-1 body, use a coin driver, etc. to loosen the four screws.

7 EJECT button

Pressing this button opens the lid of the cassette insertion slot, allowing you to take out the inserted cassette.

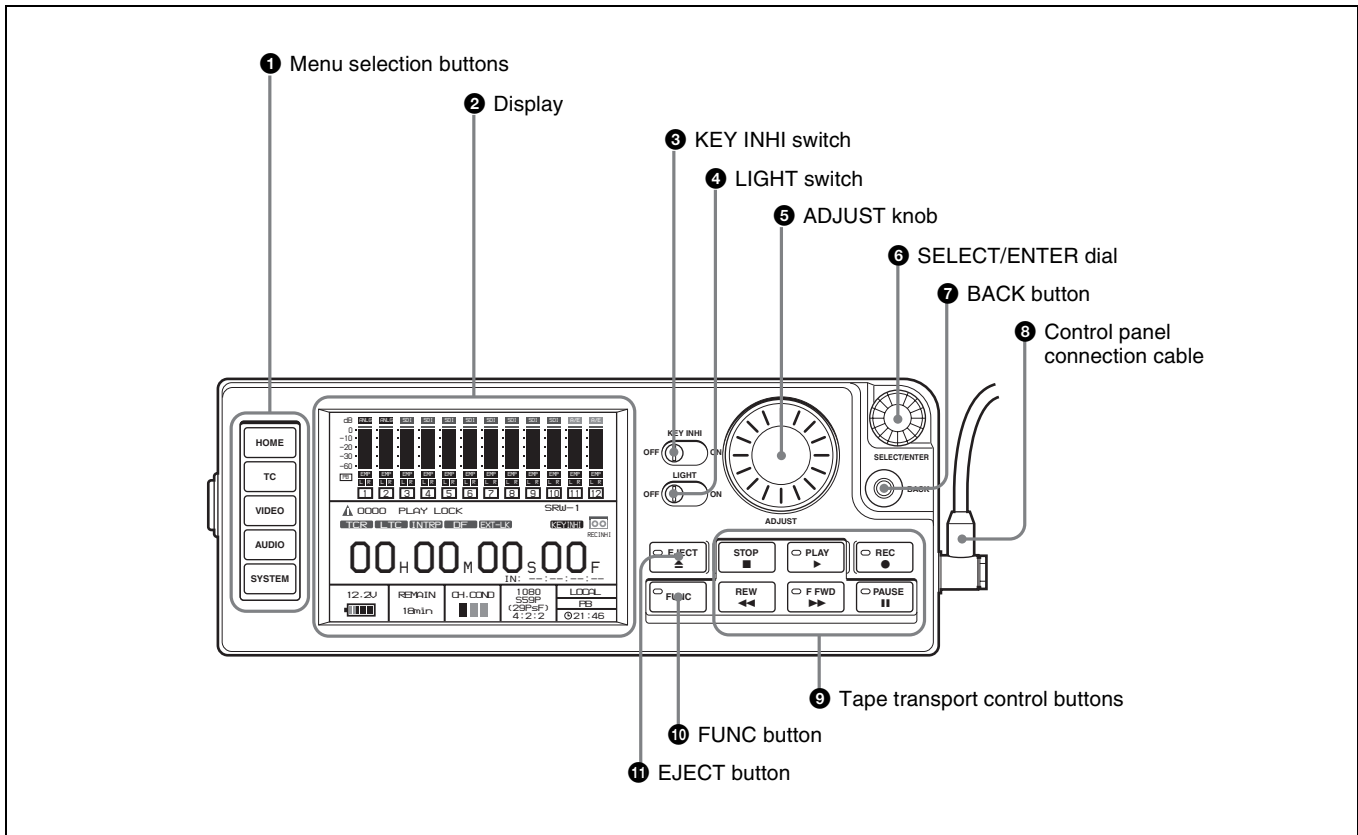
2-1-2 Control Panel**1 Menu selection buttons**

Select the menu shown on the display.

HOME button: Displays the HOME screen. The HOME screen displays audio levels, operating status, warnings, time data, and other information.

TC button: Displays the TC (timecode) Setup menu (see pages 43 to 46). This menu allows you to switch

between LTC and VITC, to switch between DF and NDF, and to display timecode on an external monitor.

VIDEO button: Displays the VIDEO Setup menu (see page 47). This menu allows you to make settings related to video.

AUDIO button: Displays the AUDIO Setup menu (see page 48). This menu allows you to make settings related to audio.

SYSTEM button: Displays the SYSTEM Setup menu (see pages 50 to 53). This menu allows you to make settings related to the entire systems, such as recording format, power, and test signal output.

See Chapter 4 “Menu Settings” (page 41) for more information about menus.

2 Display

Displays menus, audio levels, warning, operating status, time data, remaining tape time, and remaining battery power.

For details, see 2-1-3 “Display” (page 15).

3 KEY INHI (inhibit) switch

When the KEY INHI item (see page 51) in the SYSTEM Setup menu is set to ALL, setting this switch to ON disables operation buttons, to prevent misoperations due to accidental button operations.

ON: All operation buttons are disabled.

OFF: During recording, only the STOP button and PAUSE button are enabled. All buttons are enabled when the system is not recording.

When the KEY INHI item in the SYSTEM Setup menu is set to MAP, the operation buttons follow the settings of the LOCAL KEYMAP item.

4 LIGHT switch

The backlight comes on when this is set to ON.

5 ADJUST knob

Use to adjust audio levels, etc.

6 SELECT/ENTER dial

When a menu is displayed, you can rotate this dial to move the cursor, and press it to change and confirm settings.

7 BACK button

When a menu is displayed, you can press this button to back up one level in the menu structure.

8 Control panel connection cable

Connect to the SRW-1 CTRL PANEL connector.

9 Tape transport control buttons

Use these buttons for tape transport operations.

The functions of the buttons change when they are pressed together with the FUNC button.

Name	Pressed alone	Pressed with FUNC button
STOP button	Stops tape transport. Pressing this button while in standby on mode resets the still timer. Pressing the button while in standby off mode puts the SRW-1 into standby on mode.	Puts the SRW-1 into standby off mode.
PLAY button and indicator	Pressing the button starts playback. (The indicator lights during playback.) To start recording, press the button together with the REC button.	<p>Pressed with tape transport stopped: Searches for the recording end position and stops (end search).</p> <p>Pressed with recording paused: Plays the most recently recorded material, and then returns to recording pause mode (recording review). One press of the button rewinds and plays for about 3 seconds. You can keep the PLAY button pressed together with the FUNC button to rewind and play for as long as the buttons are held down (up to a maximum of 10 seconds). Recording review allows you to check whether the material was recorded correctly.</p> <p><i>You can change the setting of REC REVIEW in the SYSTEM Setup menu (see page 52) so that the SRW-1 starts a recording review from the recording start position.</i></p> <p>Note REC review is not available unless at least 3 seconds have been recorded.</p>

(continued)

Name	Pressed alone	Pressed with FUNC button
REC button and indicator	Pressing the button together with the PLAY button starts recording. (The indicator lights during recording.) If you press this button during stop, fast forward, or rewind or when no cassette is inserted, the SRW-1 enters E-E mode ^{a)} . In this mode you can monitor E-E signals ^{b)} output from the HD SDI OUT A/B connectors or the MONITOR OUT HD SDI/SD SDI connectors of the SRPC-1.	Temporarily memorizes the time data of the current position (Mark IN). Mark IN data is displayed in the format "IN: xx:xx:xx:xx" in the time data field of the display. Note The Mark IN data is memorized in the unit's internal memory only. It is erased when you eject the cassette.
REW (rewind) button and indicator	Rewinds the tape. (The indicator lights during rewinding, and goes out when rewinding completes.)	Executes reverse direction searches. With each press, the search speed changes in the order $\times 2 \rightarrow \times 5 \rightarrow \times 8 \rightarrow \times 2$ normal speed.... If a search is interrupted by another operation, the next search is performed at the speed in effect at the time of the interruption. Note When using the SRW-1 with 880 Mbps recording rate, $\times 8$ normal speed search is disabled. <i>For information about recording rate, see FORMAT >SIGNAL in the SYSTEM Setup menu on page 50.</i>
F FWD (fast forward) button and indicator	Fast forwards the tape. (The indicator lights during fast forwarding, and goes out when fast forwarding completes.)	Executes forward direction searches. With each press, the search speed changes in the order $\times 2 \rightarrow \times 5 \rightarrow \times 8 \rightarrow \times 2$ normal speed.... If a search is interrupted by another operation, the next search is performed at the speed in effect at the time of the interruption. Note When using the SRW-1 with 880 Mbps recording rate, $\times 8$ normal speed search is disabled. <i>For information about recording rate, see FORMAT >SIGNAL in the SYSTEM Setup menu on page 50.</i>
PAUSE button and indicator	Pauses tape transport. (The indicator flashes during pause.) To resume tape transport, press the button again.	Cue up a time data position specified with FUNC+REC button or SYSTEM >EDIT >IN POINT and stops. The specified time data (Mark IN data) is displayed in the format "IN: xx:xx:xx:xx" in the time data field of the display. Note The Mark IN data is memorized in the unit's internal memory only. It is erased when you eject the cassette.

a) E-E mode:

A state in which E-E signals can be monitored. Commonly used to monitor input signals before they are recorded.

b) E-E (electric to electric) signal:

A signal which passes solely through internal circuitry, and not through pathways in which magnetic conversion takes place, such as magnetic heads and tapes.

10 FUNC (function) button

When the tape transport control buttons are pressed with this button held down, the functions of the buttons change.

For details, see "9 Tape transport control buttons" (see page 13).

When the HOME button is pressed with this button held down, switches the display at the bottom of the HOME screen.

For details, see 2-1-3 "Display" (page 15).

11 EJECT button and indicator

Pressing the button opens the cover of the cassette insertion slot so that you can remove a cassette. The indicator lights during removal.

2-1-3 Display

This manual refers to the screen shown below as the HOME screen.

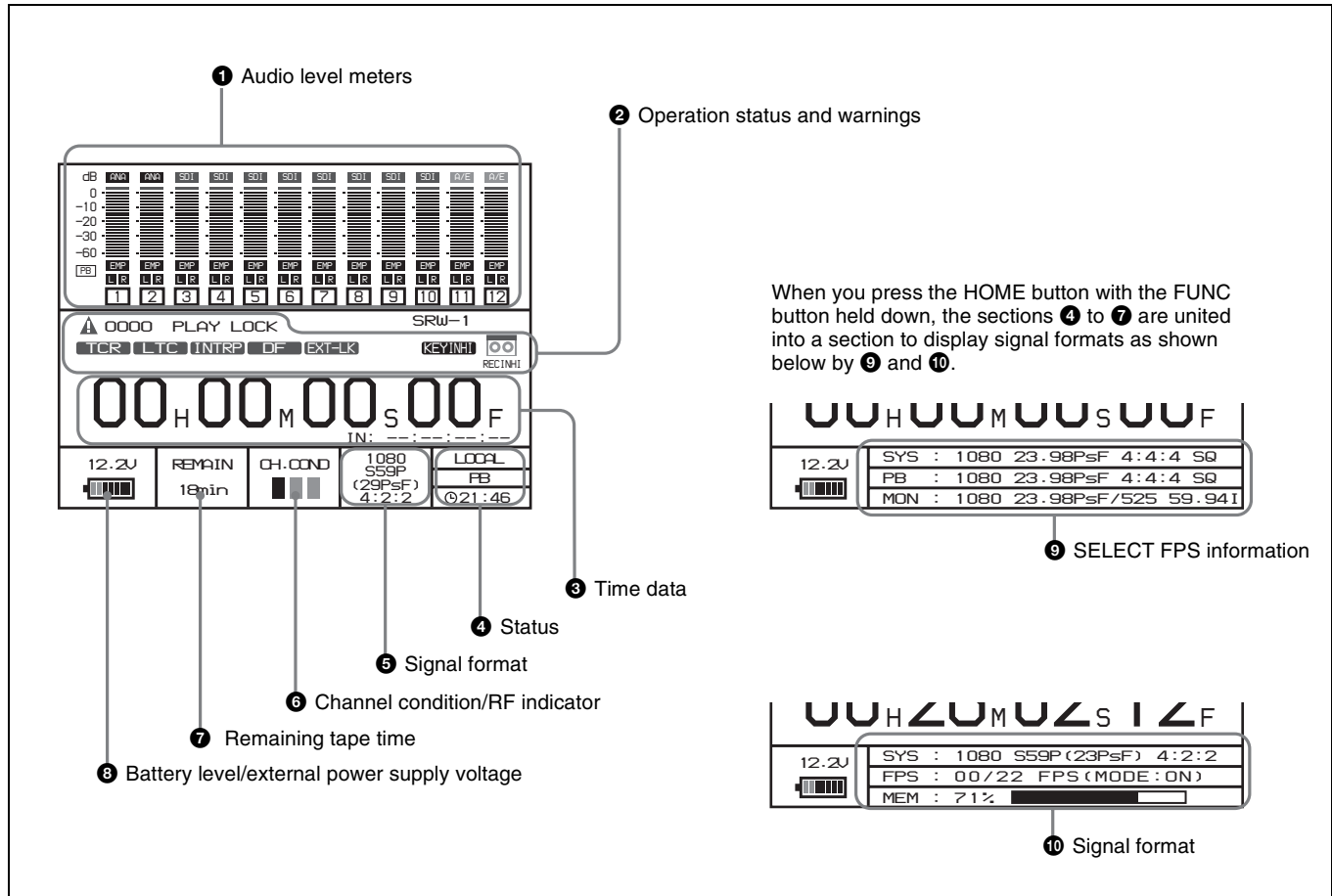

1 Audio level meters

Display recording audio levels in recording and E-E mode. Display playback audio levels during playback. The indications in the top row show the audio input signal type. The numbers 1 to 12 at the bottom are the numbers of audio tracks on the tape.

2 Operation status and warnings

Display the operation status of the system and warnings. The principal information items are as follows.

TCR/TCG/UBR/UBG/CTL: Type of time data being displayed.

LTC/VITC: When timecode is being displayed, whether it is LTC or VITC. ¹⁾

INTRP: Indicates that timecode could not be read accurately, and has been interpolated.

DF/NDF: Whether the system is in DF (drop-frame) or NDF (non-drop frame) mode.

KEY INHI: The KEY INHI switch is set to ON.

REC INHI: The cassette is record inhibited.

1) VITC (Vertical Interval Time Code):

Timecode that is inserted on two lines in the vertical blanking interval.

When you press the HOME button with the FUNC button held down, the sections 4 to 7 are united into a section to display signal formats as shown below by 9 and 10.

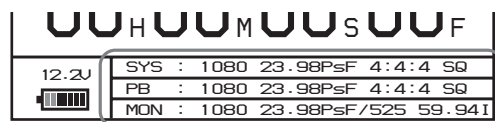

9 SELECT FPS information

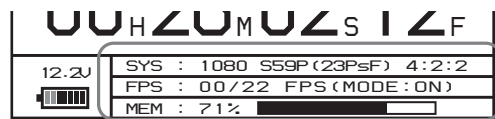

10 Signal format

This type of timecode can be read even during very slow playback or still picture playback.

For more information about warnings, see “About Warning Messages” (page 75).

3 Time data

Displays time data for the current tape position. The type of time data is CTL ¹⁾ (tape running time), timecode, or user bits, as selected in the menu system.

When Mark In data has been set by the FUNC + REC buttons or SYSTEM >EDIT >IN POINT, it is displayed in the format “IN: xx:xx:xx:xx” beneath the time data for the current tape position. When no Mark In data has been set, “IN: --:--:--:--” appears.

1) CTL signal:

This is a control signal consisting of a pulse signal recorded longitudinally on the tape for every frame of video.

4 Status

Displays the following status.

Upper row: Displays the setting of REMOTE/LOCAL in the SYSTEM Setup menu (see page 51). If REMOTE

appears, the unit can be controlled from the device connected to the REMOTE IN connector (see page 20).

Middle row: Displays the setting of POWER >MODE in the SYSTEM Setup menu (see page 52).

Lower row: Displays the real time.

5 Signal format

Displays the format of recording signals.

6 Channel condition/RF indicator

During playback, the letters “CH.COND” appear and one of the three bars (green, yellow, and red) lights to indicate the playback signal condition.

Green bar: Playback signal quality is good.

Yellow bar: Playback signal quality is degraded, but playback is possible.

Red bar: Playback signal quality is degraded. If this continues, head cleaning or internal inspection is needed.

During playback with tracking control, the “CH.COND” indication in the HOME screen flashes in yellow (see page 65).

During recording, the letters “RF” appear and a green bar or a red bar lights to indicate the recording signal condition. Normally the green bar lights. If a recording problem occurs, the red bar lights.

Green bar: Recording signal quality is good.

Red bar: Recording signal quality is degraded. If this continues, head cleaning or internal inspection is needed.

7 Remaining tape time

Displays the time remaining on the tape. “Top” is displayed at the start of the tape, and “End” is displayed at the end. The time display flashes when the tape is within three minutes of the end.

8 Battery level/external power supply voltage

Displays the current power level of the battery pack. When the battery pack is fully charged, all seven segments light up. As the battery pack discharges, the segments go out from left to right. When the battery pack is almost exhausted, the voltage indication and the tally indicator flash, and a warning tone sounds intermittently. When the battery pack is completely exhausted, the tally indicator flashes at a higher rate and the warning tone sounds continuously.

For more information, see “Warning System” (page 78).

When an external power supply is connected, the voltage of the external power supply is shown. However, the input voltage to the DC IN connector is not shown in itself. Rather the voltage actually used by the system is shown (lower than the input voltage).

For more information about the relation between segments and battery voltage, see 3-4-4 “Checking the Power and Voltage” (page 35).

9 Signal formats

When you press the HOME button with the FUNC button held down, displays the signal formats of system, playback, and monitor output, in that order from the top row.

10 SELECT FPS information

When the SELECT FPS function is on, press the HOME button with the FUNC button held down while signal formats are already displayed, the middle row changes to the FPS setting, and the bottom row changes to the memory usage ratio.

See 5-4 “SELECT FPS Function (Selectable Recording Frame Rate) (When Optional HKSR-102 Is Installed)” (page 66) for more information about the SELECT FPS function.

2-1-4 Connector Panel

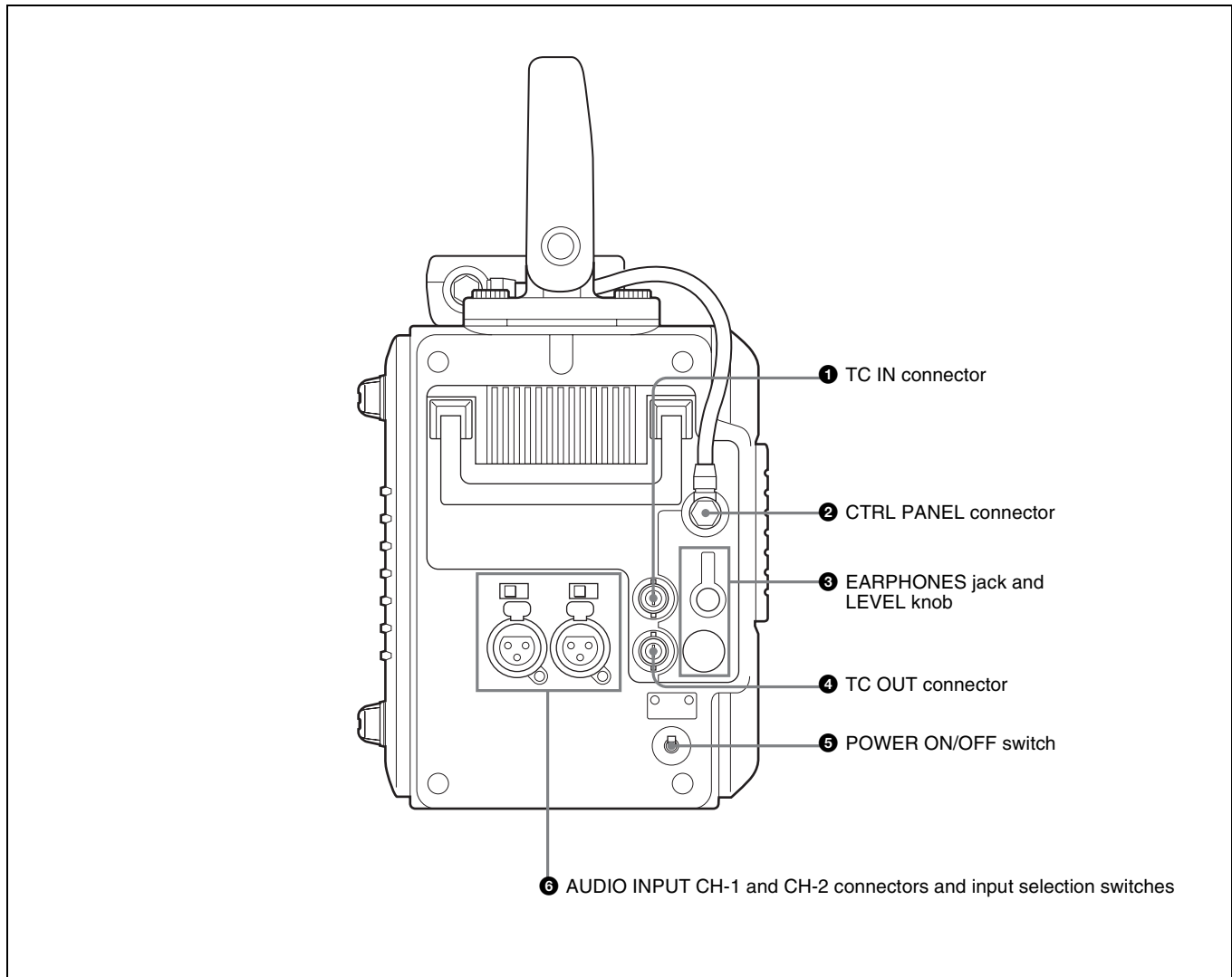

1 TC IN (timecode input) connector (BNC type)
Connect to the timecode output connector of an external device such as a timecode generator or VTR. Use this connector when locking the internal timecode generator to external timecode.

2 CTRL (control) PANEL connector
Connect the control panel. You can remove the short cable connected when the SRW-1 is shipped from the factory and replace it with the supplied extension cable.

For details, see 3-1-2 “Using the Control Panel Extension Cable” (page 25).

3 EARPHONES jack (stereo minijack) and LEVEL knob
Use this connector to attach earphones or stereo headphones equipped with a stereo miniplug, for use in monitoring audio during recording and playback. Adjust the audio level with the LEVEL knob.

A warning tone is output to the earphones/headphones when a warning is lit on the control panel display.

4 TC OUT (timecode output) connector (BNC type)
Connect to the timecode input connector of an external device such as a timecode reader or VTR. The timecode output is determined by the setting of OTHERS (MAIN) >TC OUT in the TC Setup menu as follows.

TCG (timecode generator): Timecode generated by the timecode generator is output, delayed by 1 frame. (This maintains synchronization with the output video).

AUTO: During recording (including E-E mode), timecode generated by the timecode generator is output, delayed by 1 frame. (This maintains synchronization with the output video).

During playback, the LTC signal read from the tape is output.

THRU: Timecode input to the TC IN connector is through output.

TCG (No Delay): Timecode generated by the timecode generator is output, with no delay. (The timecode is out of synchronization with the output video, being 1 frame in advance of the video.) Select this setting when you want to synchronize other devices, using the timecode generator of this unit as the master.

5 POWER ON/OFF switch

When the SRPC-1 power is on, push this switch up to the ON side to power the SRW-1 on. To power the SRW-1 off, push the switch down to the OFF side.

Normally leave this switch on the ON side since the SRW-1 is powered on and off automatically by the SRPC-1 POWER ON/OFF switch.

6 AUDIO INPUT CH-1 and CH-2 (analog audio input channels 1 and 2) connectors (XLR 3-pin, female) and input selection switches

These connectors allow up to two analog audio signals to be input from microphones and other external audio devices.

Set the input selection switches as follows, depending on the type and level of the input audio.

LINE: For line input

MIC: For microphone input

+48V ON: For input from microphones with external power supply

2-2 SRPC-1

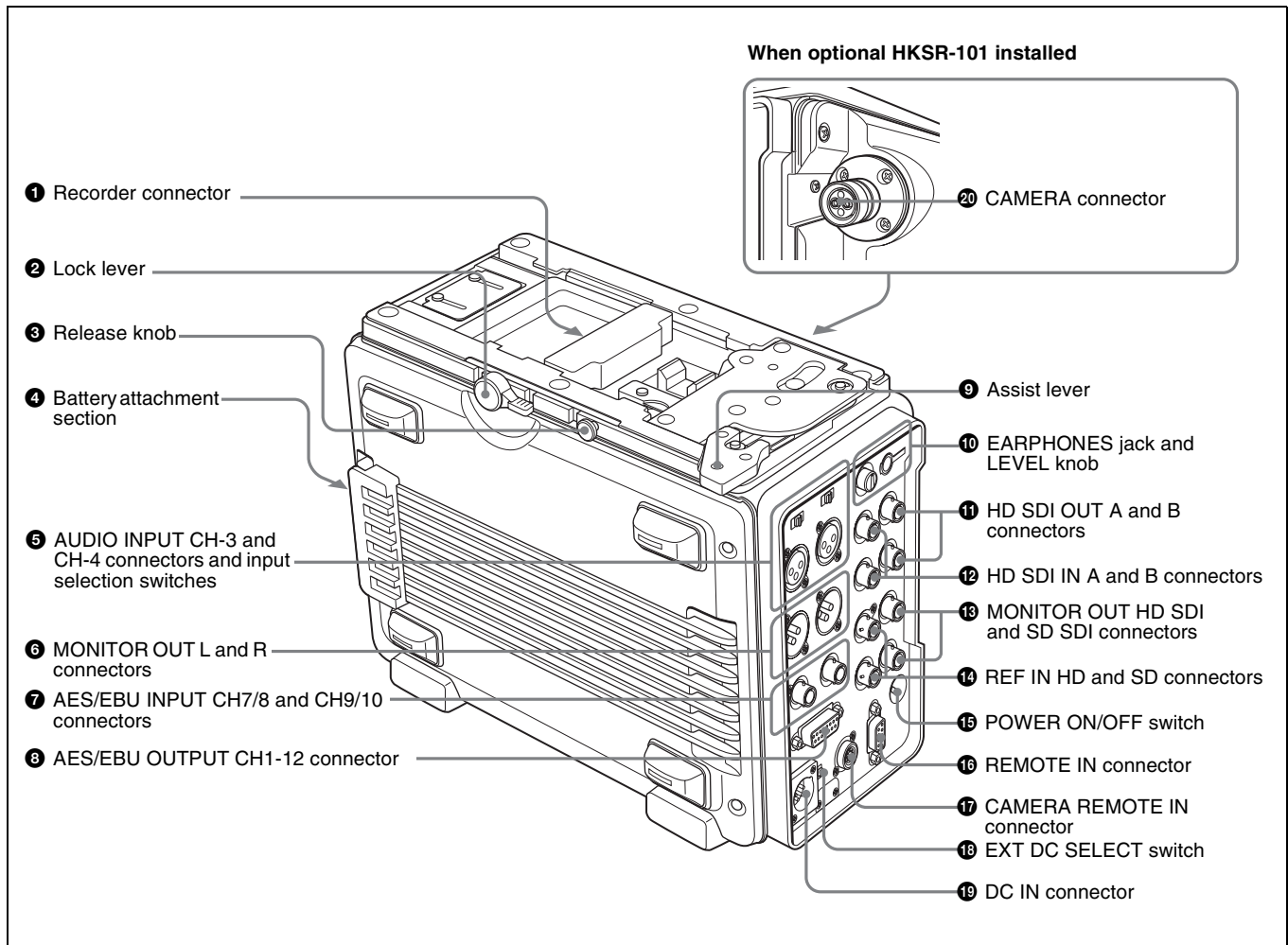

1 Recorder connector

Connect the SRW-1 HD Portable Digital Recorder.

2 Lock lever

After joining the SRW-1 and SRPC-1, rotate this lever to lock the joint.

3 Release knob

When separating the joined SRW-1 and SRPC-1, rotate the assist lever while pulling out this knob.

Note

Once you have joined the SRW-1 and SRPC-1, do not pull out the release knob except when you want to detach the SRW-1 from the SRPC-1 because doing so results in separation of these units.

4 Battery attachment section

Attach a BP-GL95/IL75 Battery Pack or AC-DN10/DN2B AC Adaptor.

For details, see 3-4 “Power Supply Preparations” (page 34).

5 AUDIO INPUT CH-3 and CH-4 (analog audio input channels 3 and 4) connectors (XLR 3-pin, female) and input selection switches

These connectors allow up to two analog audio signals to be input.

Set the input selection switches as follows, depending on the type and level of the input audio.

LINE: For line input

MIC: For microphone input

+48V ON: For input from microphones with external power supply

6 MONITOR OUT (audio monitor output) L and R connectors (XLR 3-pin, male)

Output audio monitor signals.

7 AES/EBU INPUT CH7/8 and CH9/10 (digital audio input channels 7/8 and 9/10) connectors (BNC type)

These connectors allow up to four AES/EBU format digital audio signals to be input.

Note

The AES/EBU signals must be locked to the video signal.

8 AES/EBU OUTPUT CH1-12 (digital audio output channels 1 to 12) connector (D-sub 15-pin)

Outputs up to 12 channels of AES/EBU format digital audio signals.

This connector is specially designed for this system. For details, refer to the Maintenance Manual Volume 1.

9 Assist lever

Use this lever when joining or separating the SRW-1 and SRPC-1.

10 EARPHONES jack (stereo minijack) and LEVEL knob

Use this connector to attach earphones or stereo headphones equipped with a stereo miniplug, for use in monitoring audio during recording and playback. Adjust the audio level with the LEVEL knob.

A warning tone is output to the earphones/headphones when a warning is lit on the control panel display.

11 HD SDI OUT A and B connectors (BNC type)

Output HD SDI video and audio signals.

When the signal format is 4:2:2, the signals are output from the "A" connector.

12 HD SDI IN A and B connectors (BNC type)

Input HD SDI video and audio signals.

When the signal format is 4:2:2, input the signals to the "A" connector.

13 MONITOR OUT (video monitor output) HD SDI and SD SDI connectors (BNC type)

Output SDI video and audio signals for monitoring.

HD SDI connector: Outputs HD SDI video and audio signals for monitoring.

The PD(MON) item in the VIDEO Setup menu (*see page 47*) allows you to select whether pull-down conversion of this output is performed or not.

SD SDI connector: Outputs SD SDI video and audio signals for monitoring.

Regardless of signal format settings, these connectors always output signals in 4:2:2 format.

VTR operating status and timecode can be superimposed on the output (*see the CHAR(MON) item in the TC Setup menu (page 45)*).

14 REF IN (reference signal input) HD and SD connectors (BNC type)

Input a reference video signal with the correct frame frequency.

HD connector: As an HD reference video signal, input a tri-level bipolar sync signal.

SD connector: As an SD reference video signal, input a video signal with a chroma burst signal (VBS) or black and white video signal (VS).

When carrying out recording, set REFERENCE >MODE in the SYSTEM Setup menu to "Input" so that the system is synchronized with the input video signal.

To record the input video signal in synchronization with an HD reference video signal, input an HD reference video signal of the same phase as the input video signal.

Note

When using a reference video signal, its field frequency must correspond to the system frame frequency set with FORMAT >FRAME in the SYSTEM Setup menu.

15 POWER ON/OFF switch

Powers the SRPC-1 on when pushed up to the ON side. To power the SRPC-1 off, push the switch down to the OFF side.

When the SRW-1 is joined to the SRPC-1, this switch powers both the SRW-1 and SRPC-1 on and off.

16 REMOTE IN (remote control input) connector (9-pin)

To use this unit as a playback-side VTR to perform editing in combination with another HD VTR (e.g. SRW-5500, etc.) and an editor such as a BVE-700/9100, use a 9-pin remote control cable (optional) to connect this unit to the controlling device.

Note

To control this unit from the device connected to this connector, set REMOTE/LOCAL in the SYSTEM Setup menu (*see page 51*) to RMT.

17 CAMERA REMOTE IN (remote control input) connector (8-pin)

When the optional HKS-101 Optical Interface Unit is installed, you can connect an RM-B750/B150 Remote Control Unit to this connector.

18 EXT DC SELECT (external power selection) switch

Select the operating mode when an external power supply is connected.

AUTO: Normally use the external power supply connected to the DC IN connector, but when its voltage declines, automatically switch to the power supply attached to the battery attachment section.

EXT (external): Always use only the external power supply connected to the DC IN connector.

19 DC IN connector (XLR 4-pin, male)

When using the optional AC-550/DN2B/DN10 AC Adaptor to connect to an AC power source, connect the DC power cord of the adaptor to this connector. Use only the DC power cord supplied with the AC adapter.

**20 CAMERA connector (optical-fiber connector)
(when HKSR-101 installed)**

Connect the HDC-F950 HD Color Video Camera by FC2-PD50/PD250 Optical-Fiber Cable (optional). A single optical-fiber cable can send and receive audio and control signals multiplexed into video signals.

Refer to the HKSR-101 Installation Manual for information about installing the HKSR-101.

Notes

- Power cannot be supplied from this unit to a camera over optical-fiber cable.
- Communications errors can occur if dust accumulates on the surface of the connector of the optical-fiber cable. Always clean the CAMERA connector before use. Whenever the CAMERA connector is not in use, always cover it with the cap supplied with the HKSR-101.

Refer to the HKSR-101 Installation Manual for information about cleaning the optical-fiber connector.



3-1 Assembly

3-1-1 Joining the SRW-1 and SRPC-1

When using the optional HKSR-101 Optical Interface Unit, refer to the HKSR-101 Installation Manual.

To mount the SRW-1 on the SRPC-1, proceed as follows.

- 1 Place the SRPC-1 on a flat, stable surface of a bench, table or the like.
- 2 Rotate the lock lever counterclockwise (*see the figure for step 3*) until it is almost horizontal.
- 3 Move the assist lever to the unlock position (rotate it in the direction of the arrow as far as it will go).

Note

If the top handle is detached from the SRW-1, grasp the side handle with one hand and mount the SRW-1 while supporting it with your other hand.

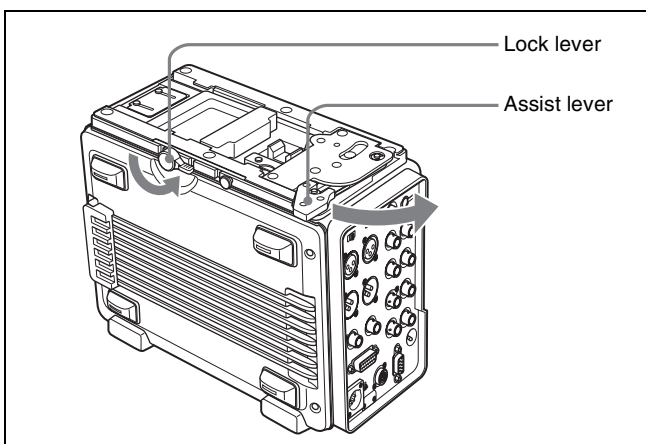

- 4 Grasp the top handle of the SRW-1, align the I mark on the SRW-1 with the ▲ mark on the SRPC-1 (*see "To release" in the following figure*), and then place the SRW-1 on the top of the SRPC-1.

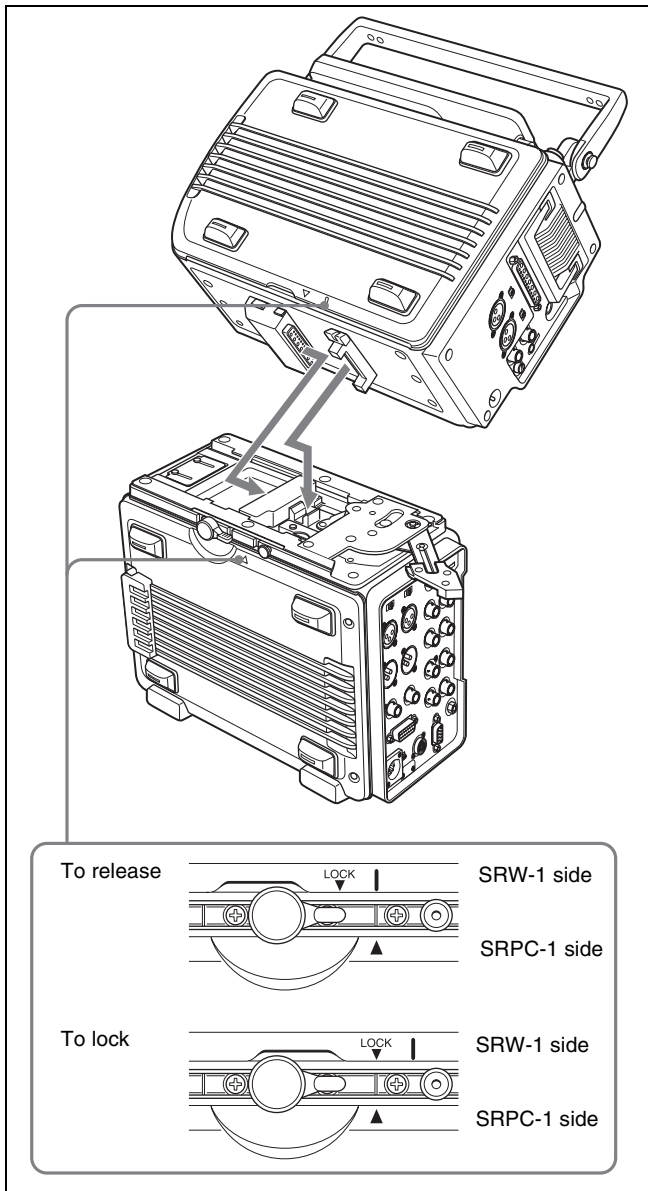

- 5** Rotate the assist lever back to its original (lock) position to align the LOCK ▼ mark on the SRW-1 with the ▲ mark on the SRPC-1. (See “To lock” in the previous figure.)

When you do this, check to be sure that the release knob (see the following figure) is all the way in.

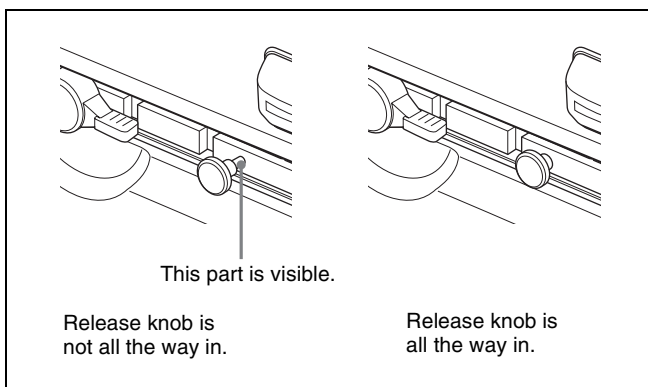

Next, by attempting to rotate the assist lever again to the lock position, check to be sure that now the assist lever will not go beyond half the way and that the SRW-1 keeps joined to the SRPC-1.

Caution

The SRW-1 and SRPC-1 are not properly joined unless the release knob is all the way in. They may come apart, or the SRW-1 may fall off.

- 6** Rotate the lock lever on the side panel of the SRPC-1 in the direction of the arrow to lock the joint between the SRPC-1 and SRW-1.

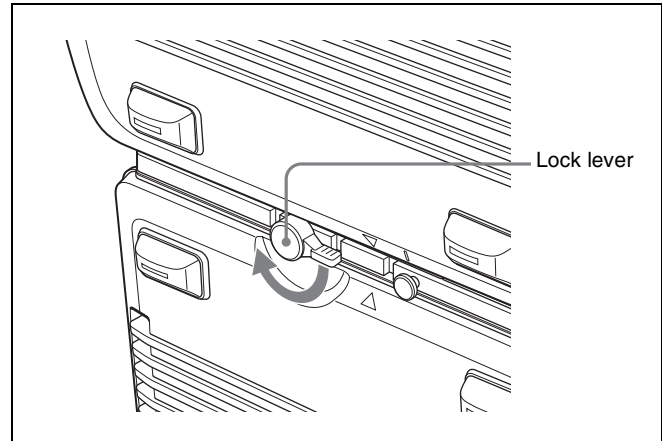

- 7** Remove the two screws from the holes on the SRW-1, and use these two screws to mount the supplied assist lever holding bracket on the SRW-1.

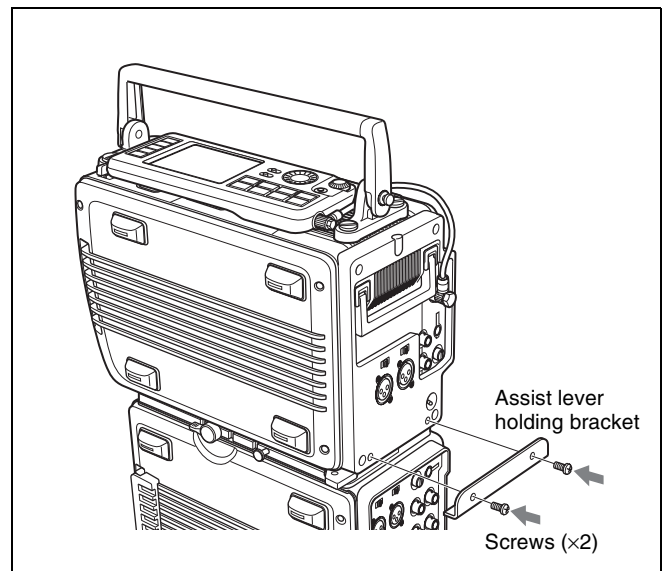

To detach the SRW-1 from the SRPC-1

- 1** Place the joined SRPC-1 and SRW-1 on a flat, stable surface of a bench, table or the like.

- 2 Unscrew the assist lever holding bracket from the body of the SRW-1.
- 3 Rotate the lock lever on the side panel of the SRPC-1 in the direction of the arrow to unlock the joint between the SRPC-1 and SRW-1.

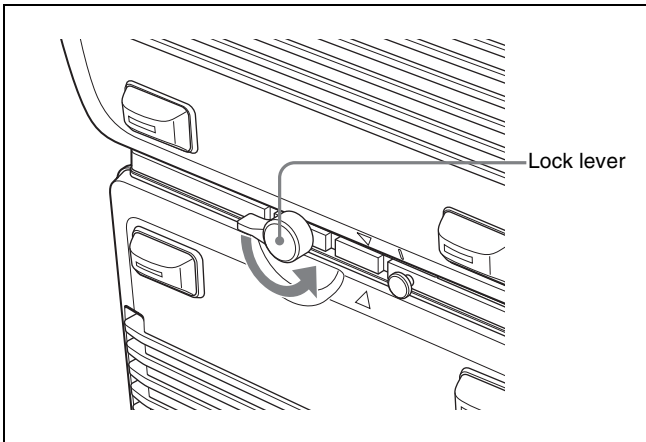

- 4 While pulling out the release knob on the side panel of the SRPC-1, rotate the assist lever in the direction of arrow and then slide the SRW-1.

The I mark on the SRW-1 is aligned with the ▲ mark on the SRPC-1. (See “To release” in the figure on page 24.)

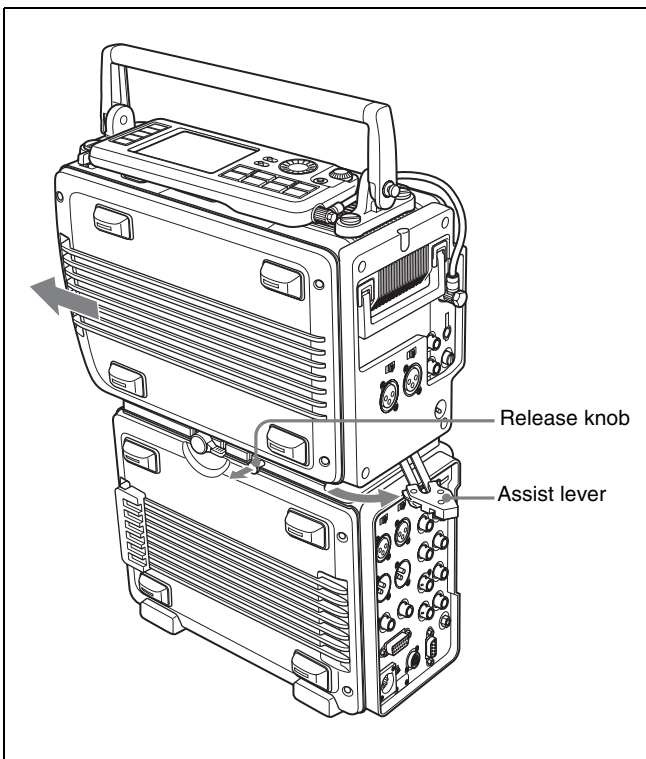

- 5 Lift the SRW-1 off the SRPC-1.
- 6 Move the assist lever to the lock position.

3-1-2 Using the Control Panel Extension Cable

When they are shipped from the factory, the control panel and SRW-1 are connected by a short cable. You can replace this cable with the supplied extension cable, which allows you to use the control panel apart from the SRW-1. Proceed as follows.

- 1 Disconnect the short cable from the CTRL PANEL connector on the SRW-1. (See the following figure.)
- 2 While pressing the lock release button next to the control panel, slide the control panel in the direction of the arrow in the figure to separate the control panel from the SRW-1 body.

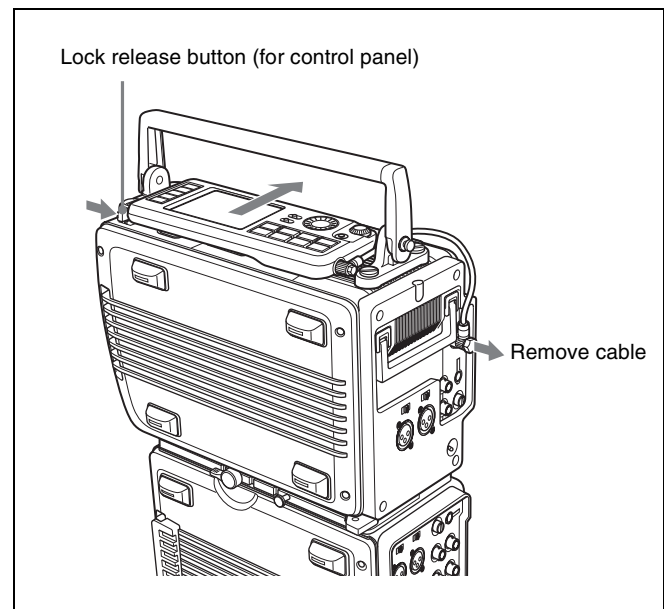

- 3 Remove the cable from the control panel and replace it with the extension cable.
- 4 Connect the extension cable to the CTRL PANEL connector on the SRW-1.

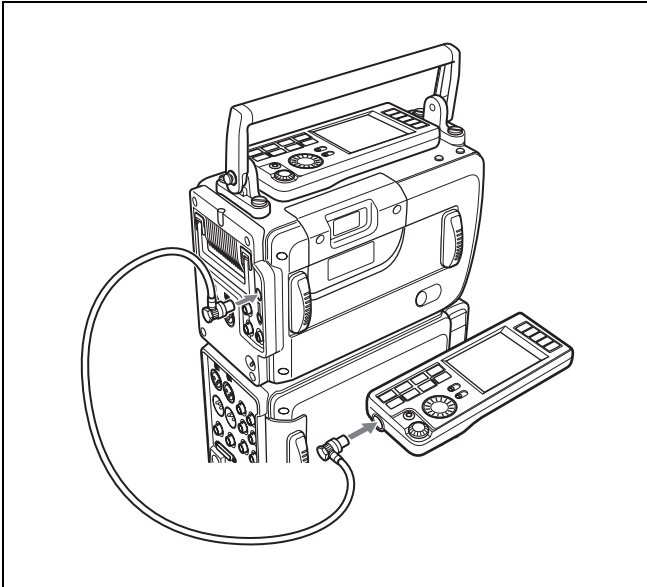

To secure the extension cable with the cable clamp

You can attach the cable clamp supplied with the SRW-1 to secure part of the extension cable. Proceed as follows.

- 1 Remove the two screws from the SRW-1. (See following figure.)
- 2 Attach the supplied cable clamp to the SRW-1 using the screws removed in step 1.

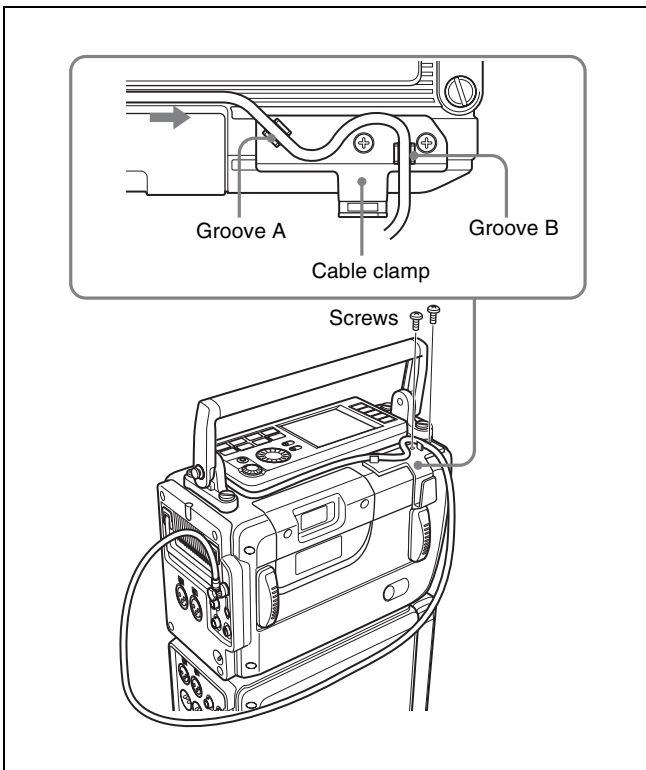

- 3 Gently pull the part of the cable closest to the control panel in the direction of the arrow so that there is

almost no slack, then fix the cable in groove A and groove B. (See figure in step 2.)

- 4 While avoiding the cassette insertion slot, fix the slack part of the rest of the cable in the clamp.

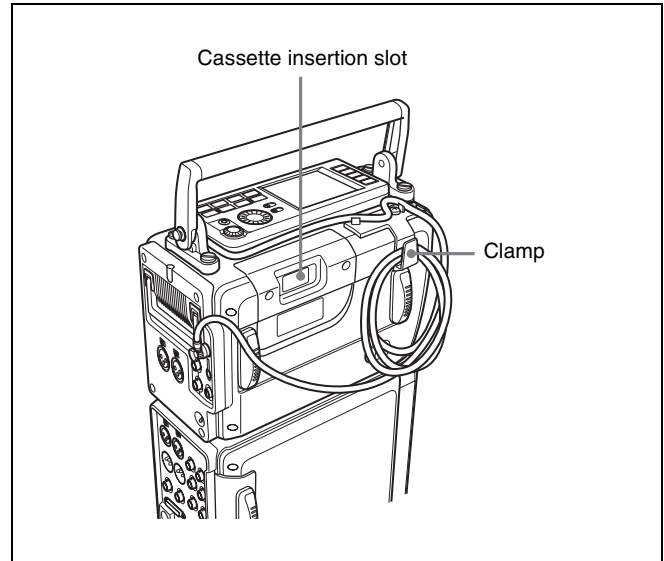

3-2 Connections

This section explains how to make connections for recording and playback.

3-2-1 Connections for Recording

The following figures show connections between this unit and a camera or camcorder.

About monitor connections, see the figures in 3-2-2 “Connections for Playback” (page 29).

To connect the HDW-F900 to record 4:2:2 signals

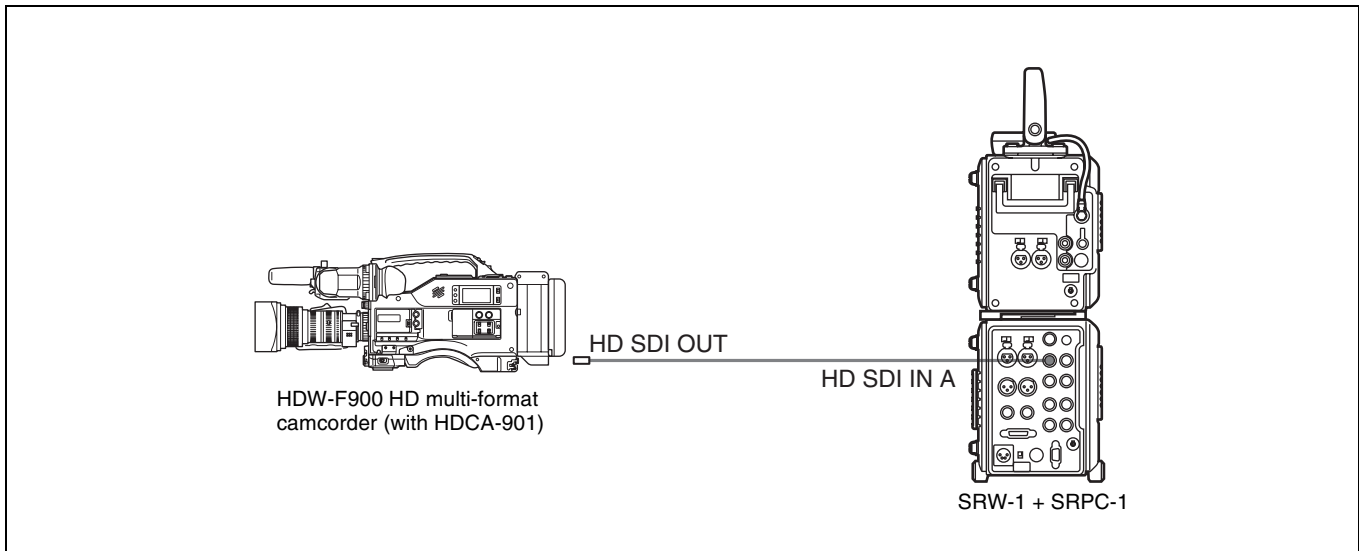

To connect the HDC-F950 to record RGB 4:4:4 signals

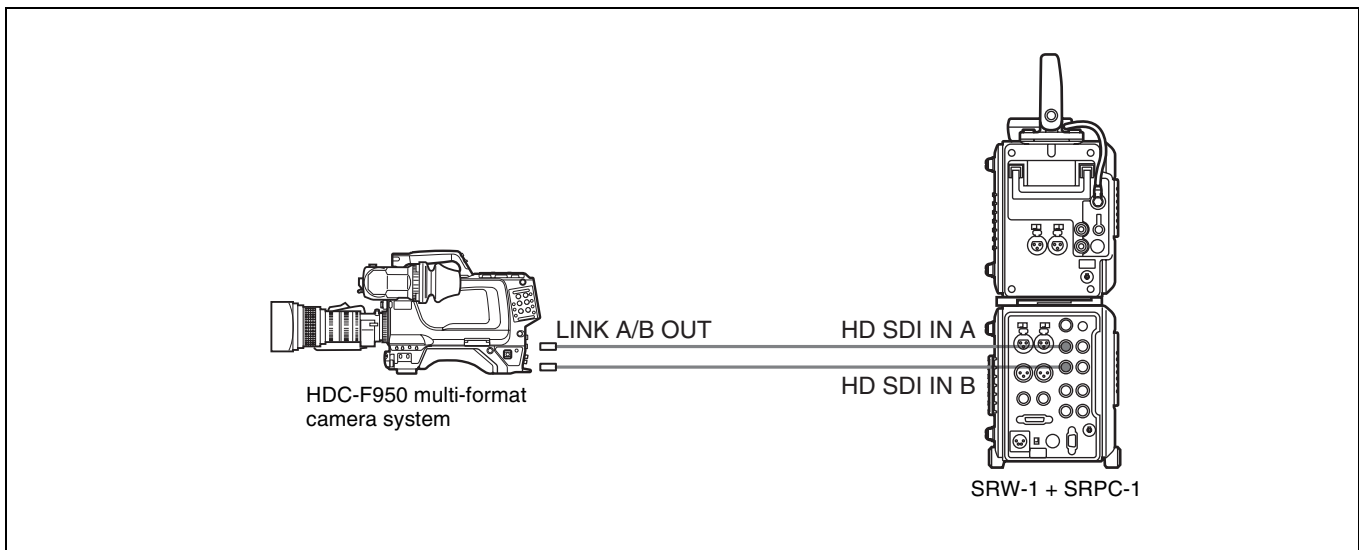

To record the output of 2 camera systems as 4:2:2 DUAL STREAM

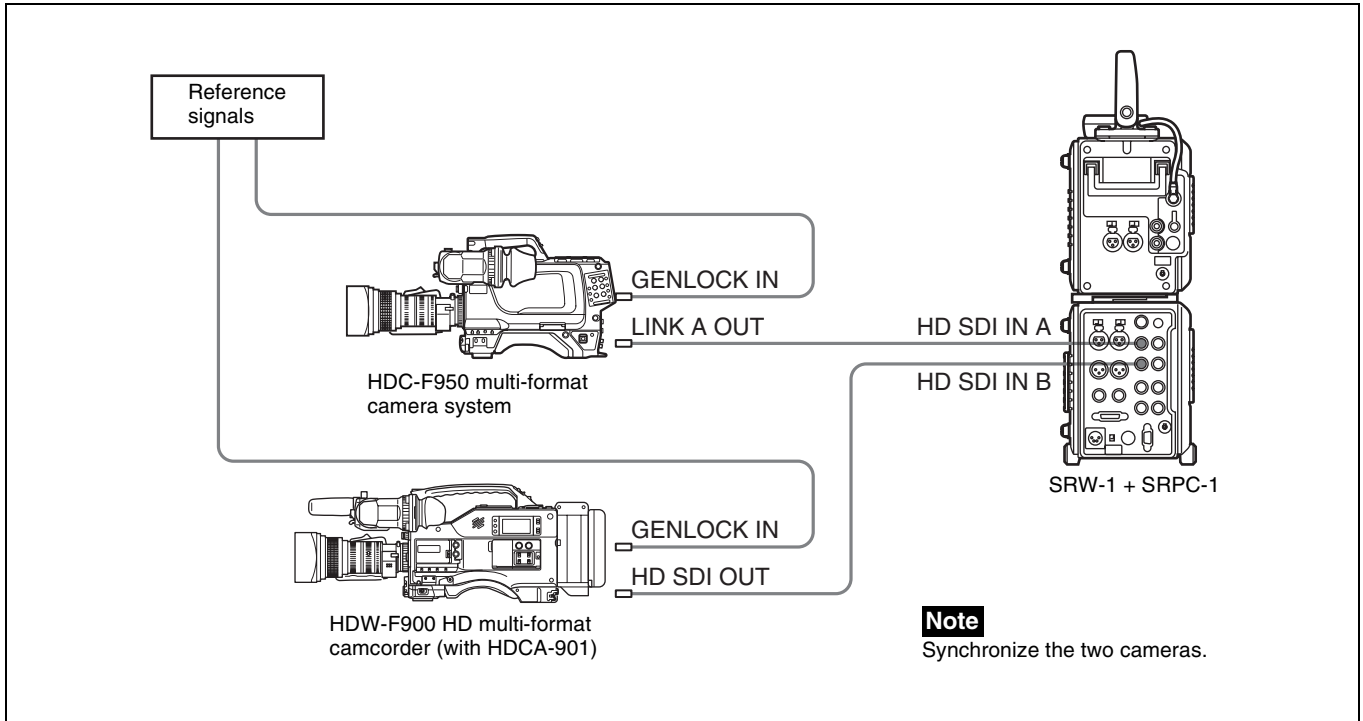

To record 4:2:2 or 4:4:4 signals using optical-fiber cable

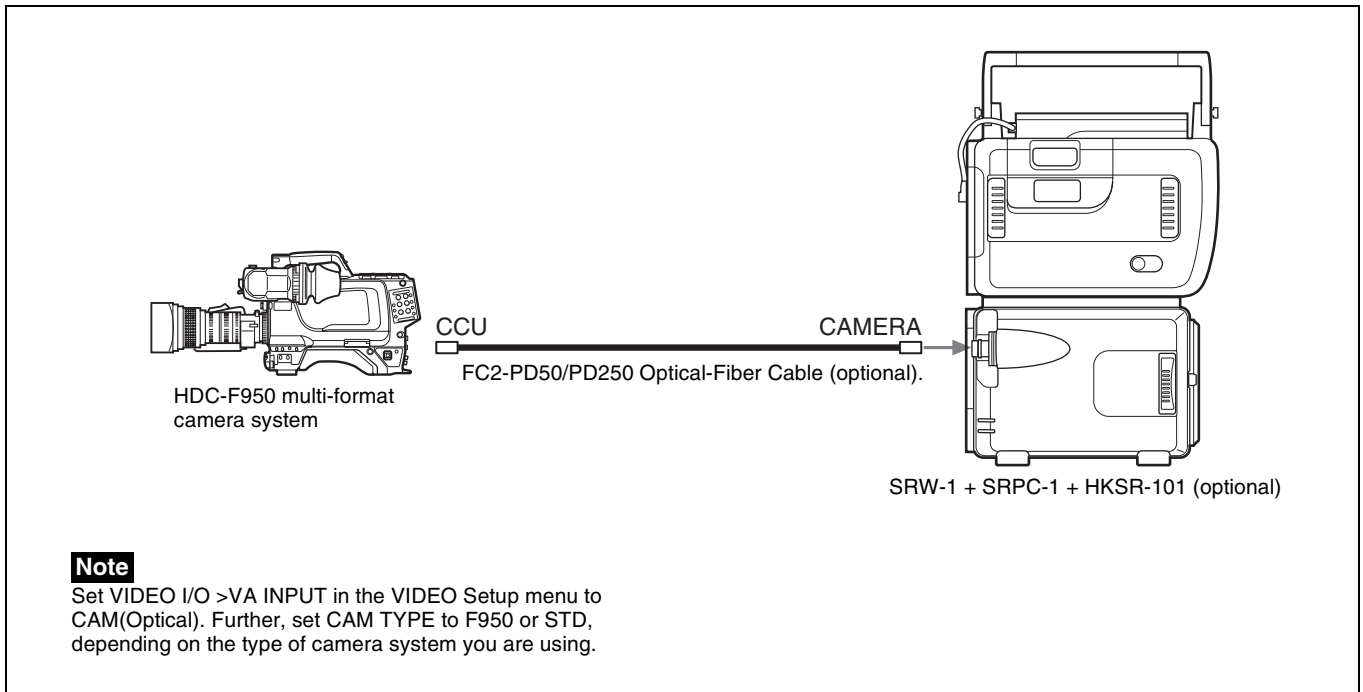

3-2-2 Connections for Playback

To connect an HD monitor

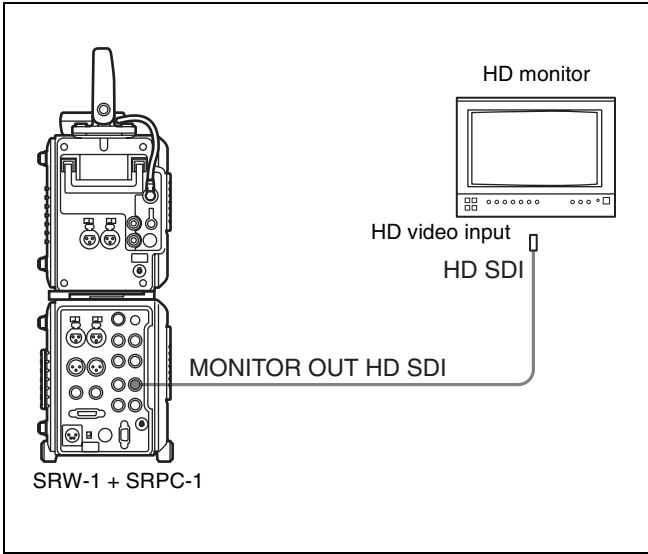

To connect an HD monitor supporting RGB 4:4:4 (Dual Link)

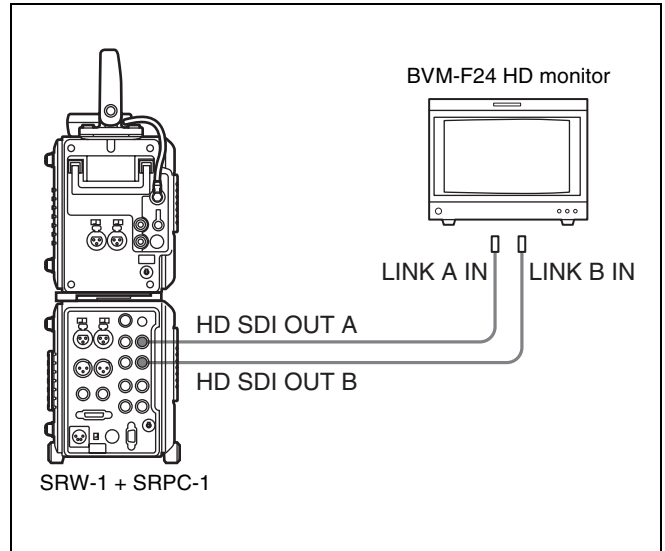

To connect an NTSC monitor

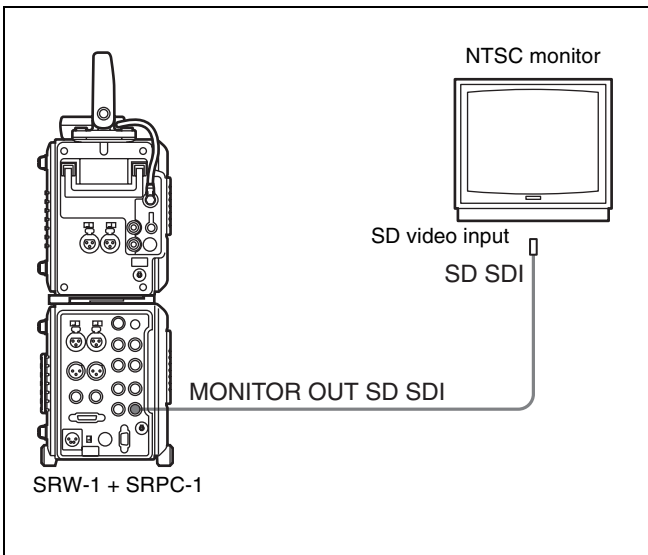

3-3 About Reference Sync Signals

This section explains how to select reference signals for video output signals.

3-3-1 Reference Signals for Video Output Signals

The video signals output from this system are synchronized as shown below, depending on the operating state of the system, SYSTEM Setup menu settings (see page 50), and input signals.

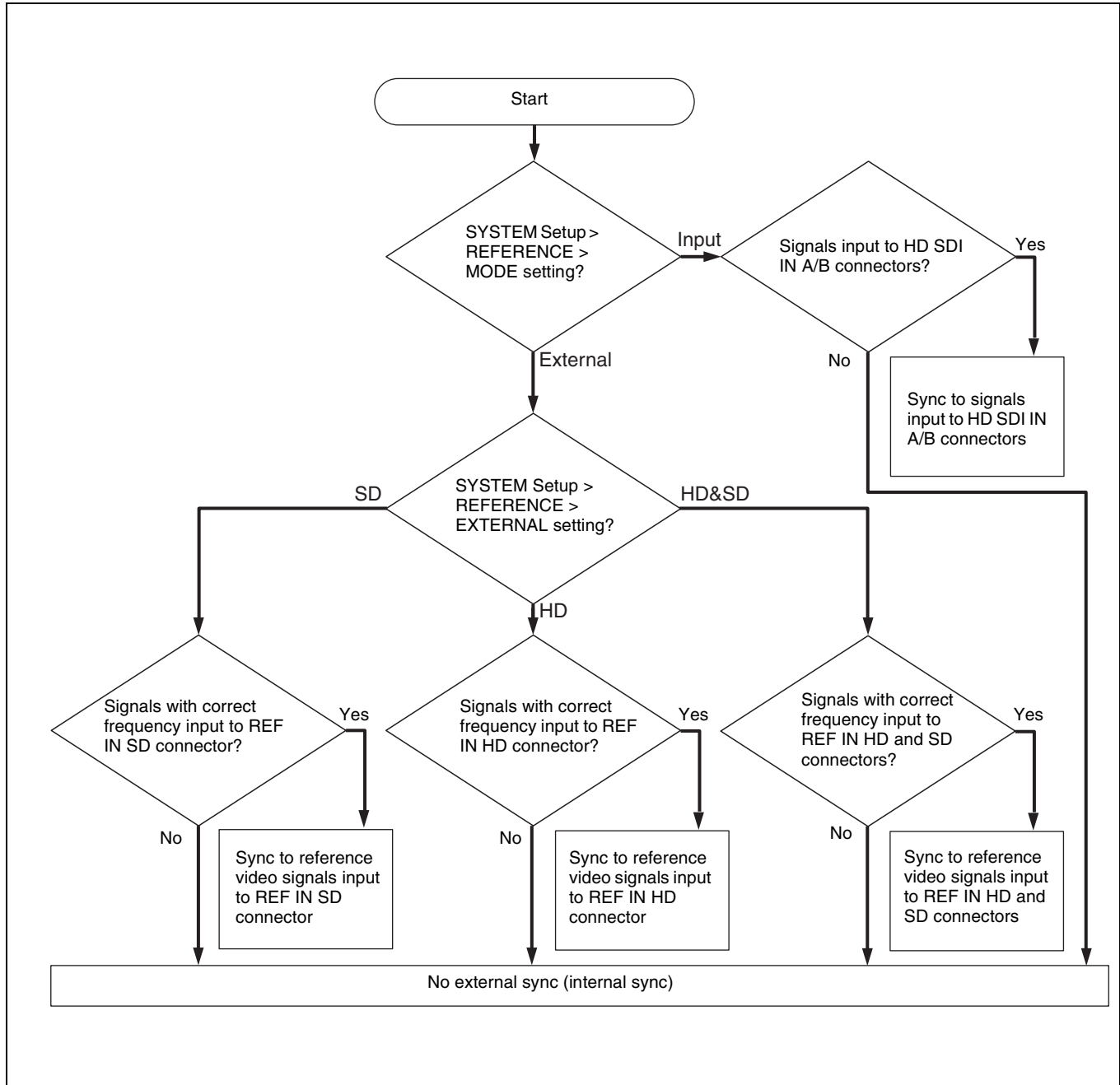

3-3-2 Connecting Reference Signals (Examples for When External Sync Is Required)

Connect reference signals as explained below, depending on how you want to use the system.

Connections to record signals from cameras, switchers, signal generators, etc.

In the SYSTEM Setup menu, set REFERENCE >MODE to “Input” (see page 50), and then connect as shown below.

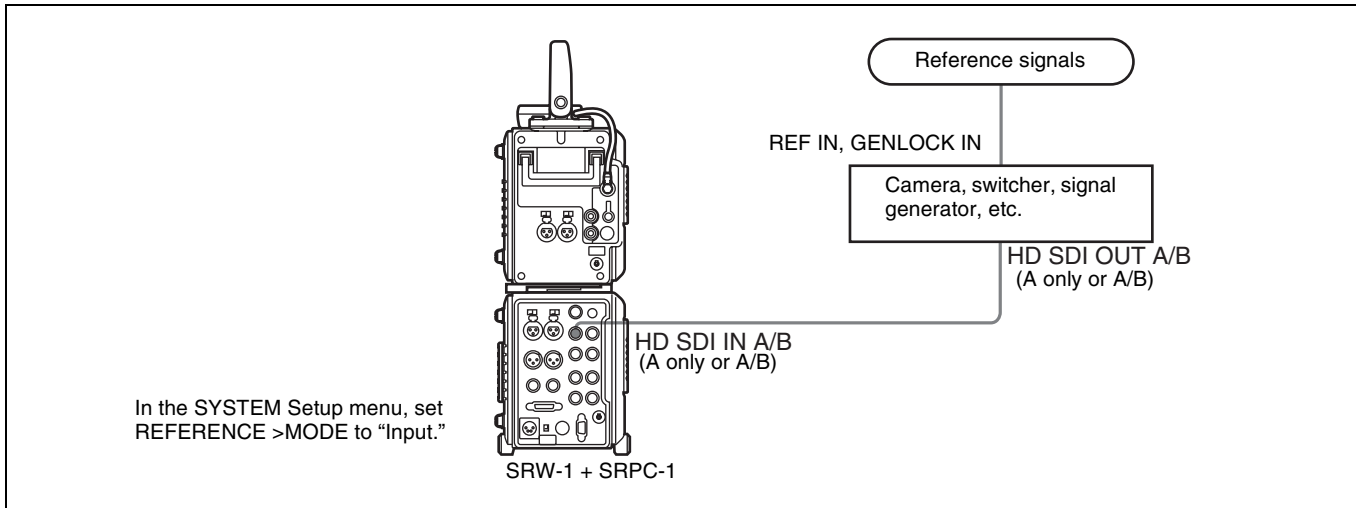

Connections to record using optical-fiber cable

To record using an optical-fiber connection between this unit and the HDC-F950 camera, with the optional HKSR-101 installed in the SRPC-1, the first step is to synchronize by supplying reference signals from this unit to the HDC-F950 over the optical-fiber cable. Next, output signals from the synchronized HDC-F950 are input to this unit, replacing the reference signals of this unit.

If you do not want to input external reference signals to this unit, set REFERENCE >MODE (see page 50) in the SYSTEM Setup menu to “Input”.

When you need to input external reference signals to this unit

Set REFERENCE >MODE in the SYSTEM Setup menu to “External”, and set REFERENCE >EXTERNAL to the appropriate value for the reference signals that you are using (see page 50).

If you want to input an HD tri-level sync signal to the REF IN HD connector, set REFERENCE >EXTERNAL to “HD” and make the connections shown below.

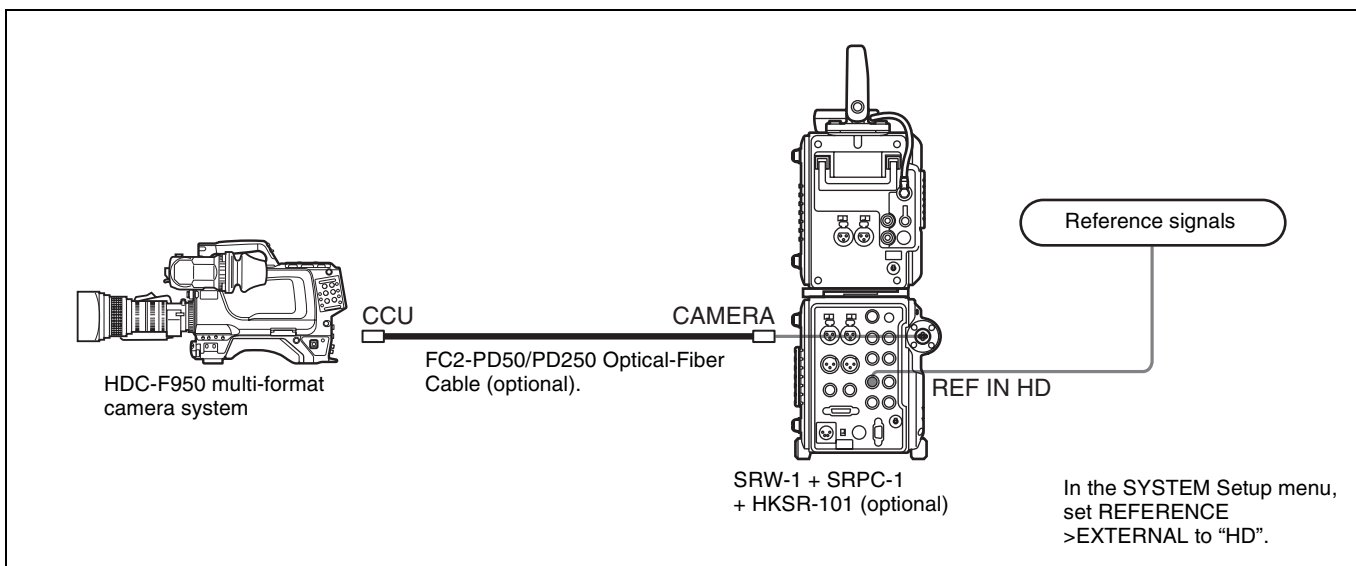

Connections to input playback signals to an external HD VTR

In the SYSTEM Setup menu, set REFERENCE >MODE to “External,” set REFERENCE >EXTERNAL to “HD” (see page 50), and then connect as shown below.

Note

When you make the menu settings described at left, always input an HD tri-level sync signal to the REF IN HD connector.

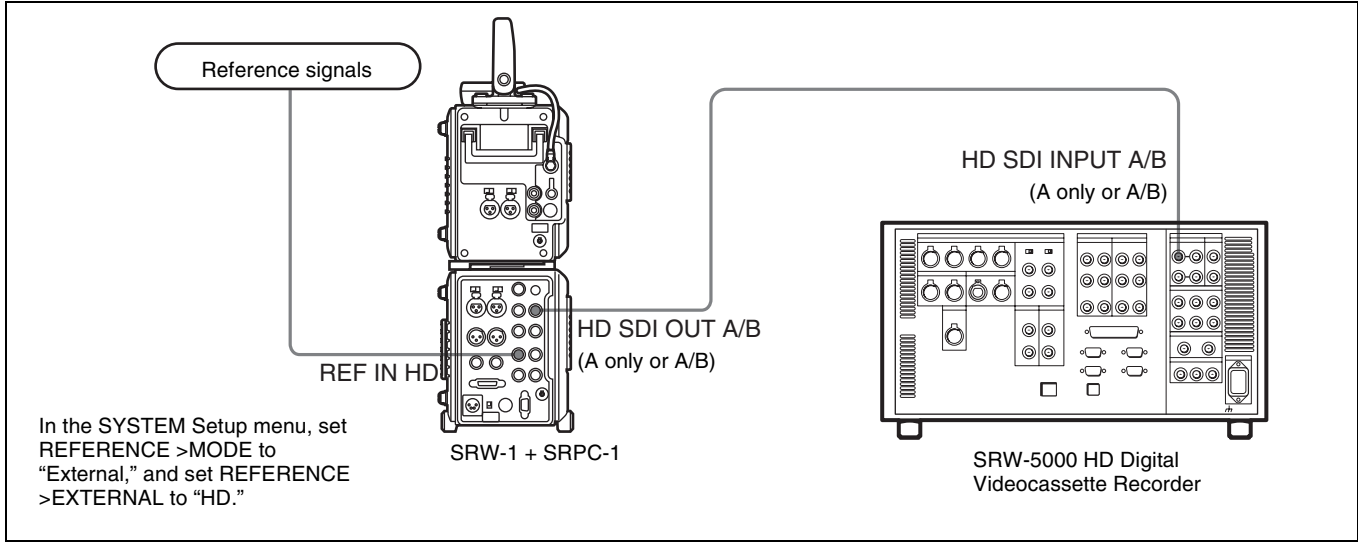

Connections to output playback signals from this system (synchronized with both 23.98PsF and 59.94i)

When the frame frequency is 23.98PsF, you can synchronize pulldown output signals and downconvert output signals to a 59.94i reference signal input to the REF IN SD connector.

In the SYSTEM Setup menu, set REFERENCE >MODE to “External,” set REFERENCE >EXTERNAL to “HD&SD” (see page 50), and then connect as shown below.

Notes

- These settings are valid only when the frame frequency of this system is 23.98PsF.
- When you make the settings described at left, always input the appropriate reference signals to the REF IN HD and REF IN SD connectors. These reference signals must be synchronized. A warning message appears if they are not synchronized.

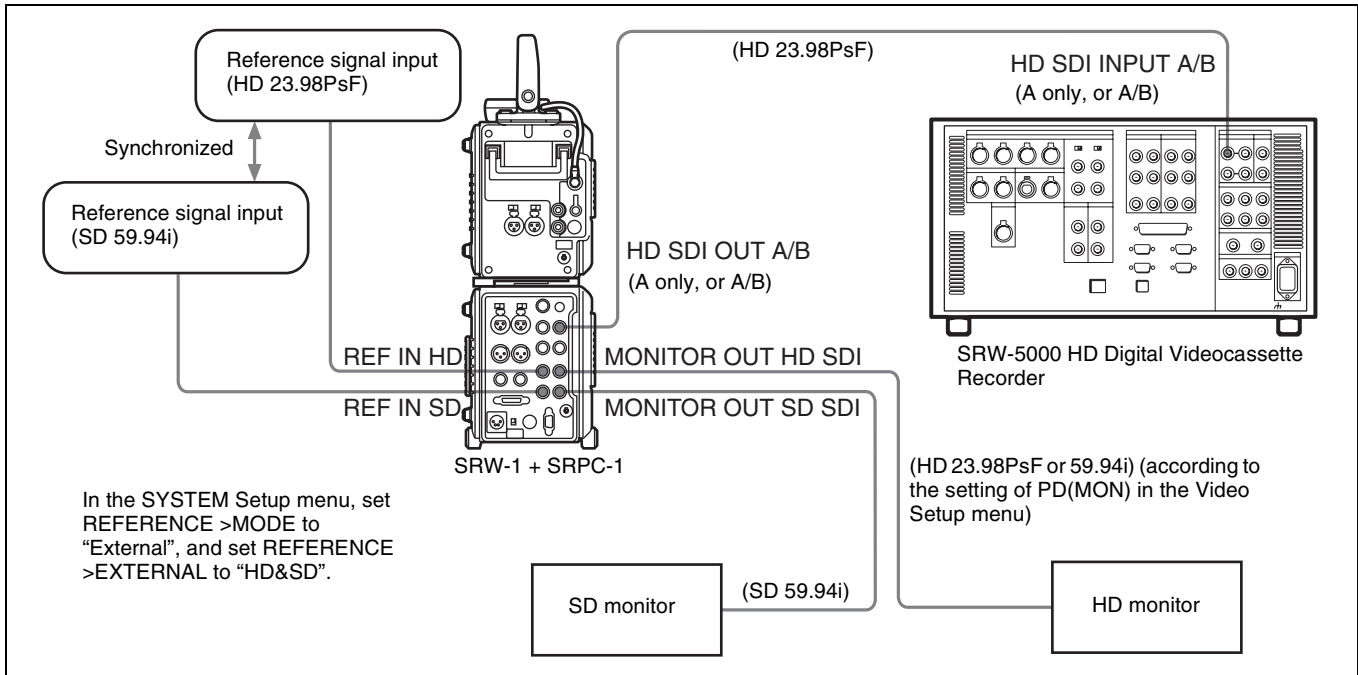

Connections to output playback signals from this system (synchronized with SD59.94i or SD50i)

When the frame frequency is 29.97 Hz/25 Hz, you can use a VBS reference signal input to the REF IN SD connector as the playback reference signal.

In the SYSTEM Setup menu, set REFERENCE >MODE to “External,” set REFERENCE >EXTERNAL to “SD” (see page 50), and then connect as shown below.

Notes

- These settings are valid only when the frame frequency of this system is 29.97 Hz/25 Hz.
- Do not connect a reference signal to the REF IN HD connector.
- Input a VBS signal conforming to the operating frame frequency to the REF IN SD connector.

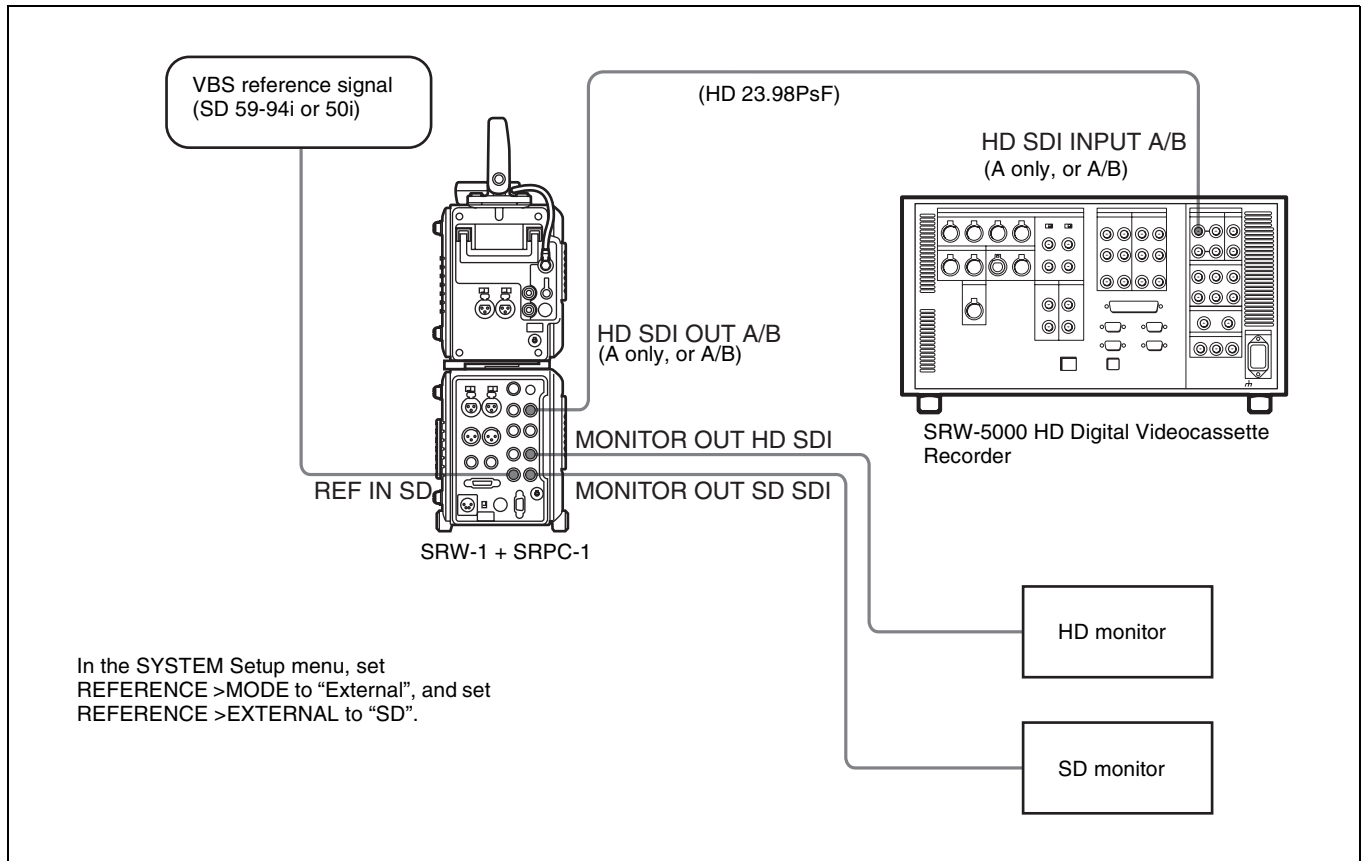

3-4 Power Supply Preparations

This system can be used with a battery pack or AC power.

3-4-1 Using a Battery Pack

The battery pack usable with this system is the BP-GL95/IL75.

Before use, charge the battery pack with the special battery charger.

Detach the battery pack if you will not be using the system for an extended period of time.

Refer to the operation manual of the battery charger for more information about how to charge battery packs.

To attach a battery pack

- 1 While pressing in the lock release button on the battery attachment section of SRPC-1, slide the battery connector cover to remove it. (See the figure in the next item, "To detach a battery pack".)
- 2 Align the line on the battery attachment section of the SRPC-1 with the line on the side of the battery pack.

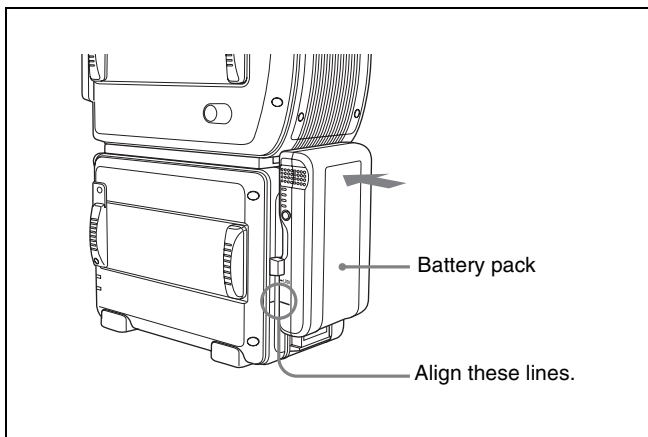

- 3 Slide the battery pack down until its LOCK arrow points at the matching line on the SRPC-1.

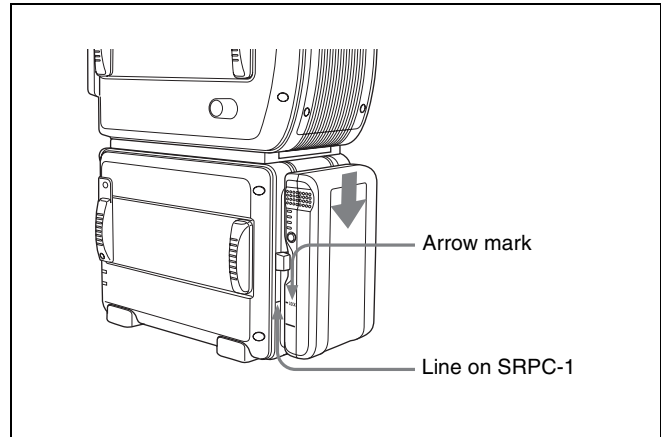

To detach a battery pack

While pressing the lock release button on the battery attachment section, slide the battery pack in the direction opposite to the direction in which you attached it.

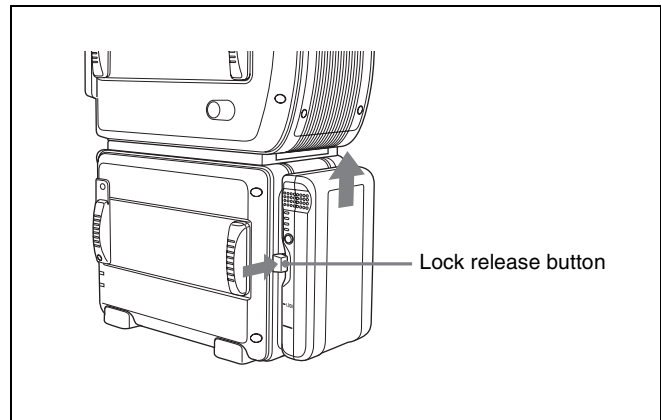

Note

Compared to equipment such as the HDW-F900 camcorder, the battery attachment section of the SRPC-1 is closer to the ground.

For this reason, you should be careful when moving the system with a battery pack attached as shown in the above figure, to prevent the bottom of the battery pack from striking the ground, which may cause it to come off.

3-4-2 Using AC Power

The AC adaptors usable with this system are the AC-550 and the AC-DN10/DN2B.

Both adaptors are supplied with DC power cords, which are connected to the DC IN connector on the rear panel of the SRPC-1.

The AC-DN10/DN2B can also be attached to the battery attachment section of the SRPC-1.

To attach the AC-DN10/DN2B

Refer to "To attach a battery pack" (page 34) and attach in the same way.

Note

If you are attaching an AC adaptor to the battery attachment section, set BATTERY >BATT TYPE in the SYSTEM Setup menu to “AC Adapter” (see page 53). If you are connecting an AC adaptor to the DC IN connector, set BATTERY >DC IN TYPE in the SYSTEM Setup menu to “AC Adapter”.

3-4-3 Powering On and Off

To power on

To power the SRW-1 and SRPC-1 on, proceed as follows.

- 1 If you are using an AC adaptor, turn the AC adaptor on.
- 2 Turn the SRPC-1 POWER ON/OFF switch to ON.
The SRW-1 is powered on automatically when its POWER ON/OFF switch is set to ON.

Powering on when the optional HKSR-101 is installed

If you have installed the optional HKSR-101 in SRPC-1 to connect this unit to a HDC-F950 camera via optical-fiber cable, power on in the order this unit on → HDC-F950 on. Signal transmission may not be conducted properly if this power-on order is not observed.

To power off

Note

To protect tapes, do not power the SRW-1 off with a cassette loaded. Always eject the cassette first, and then use the following procedure to power the system off.

- 1 Turn the SRPC-1 POWER ON/OFF switch to OFF.
If the SRW-1 POWER ON/OFF switch is set to ON, the SRW-1 is also powered off automatically.
- 2 If you are using an AC adaptor, turn the AC adaptor off.

If you should ever power off with a cassette still loaded in the SRW-1, the unit does not power off immediately. To protect the tape, the unit powers off after first returning the tape to the unthread position.

3-4-4 Checking the Power and Voltage

To check the type of power being used

A battery mark appears in the lower left of the control panel display when power is being supplied from the battery attachment section.

A power plug mark appears when an AC adaptor is selected as power supply.



Note that this mark does not reflect the actual type of power being used, but reflects the settings of the following menu items.

- SYSTEM Setup >BATTERY >BATT TYPE
- SYSTEM Setup >BATTERY >DCIN TYPE

To check the remaining battery power

You can check the remaining battery power with the battery level display.

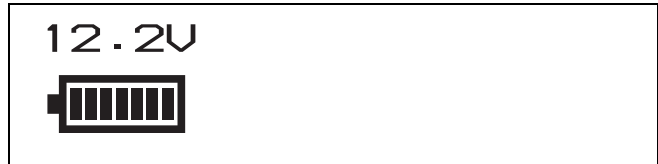

As the battery pack discharges, the segments go out from left to right. When the battery pack is almost exhausted (NEAR END), the voltage indication and the tally indicator start to flash, and an intermittent warning tone sounds in the headphones. When the battery pack is completely exhausted (END), the corresponding warning indication lights, the tally indicator starts to flash at a higher rate, and the headphones warning tone sounds continuously.

The BATTERY item in the SYSTEM Setup menu (see page 53) allows you to set the battery voltages for which NEAR END and END warnings are issued.

3-5 Display Settings

If the display is hard to see because of low light conditions, you can set the LIGHT switch to ON to turn on the backlight.

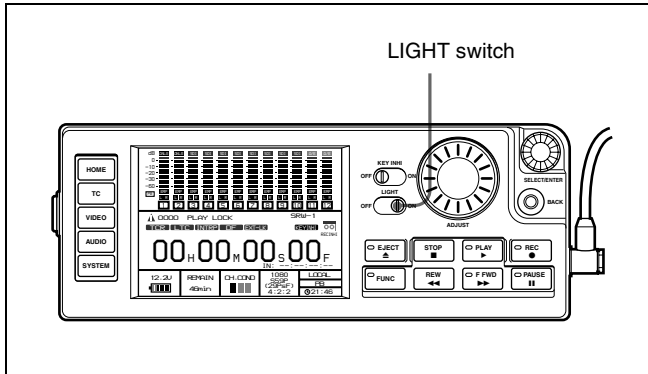

To make the backlight brighter

Select LCD >BRIGHT in the SYSTEM Setup menu (see page 51) and adjust the brightness (0 to 31) in the Backlight Brightness window.

To turn the backlight off after a specified interval

Select LCD >LIGHT OFF in the SYSTEM Setup menu (see page 51) and select the time that the backlight should remain on (5 seconds to 5 minutes) in the Backlight Off Timer window.

To keep the backlight on, select “Disable.”

To display a screen saver after a specified interval

Select LCD >SAVER in the SYSTEM Setup menu (see page 51) and select the time after which the screen saver should appear (1 minute to 1 hour) in the Screen Saver window.

Select “Disable” if you do not want to display a screen saver.

See 4-1 “Basic Menu Operations” (page 41) for more information about menu operations.

3-6 Superimposed Text Information

Timecode, operating modes, warning/error messages, and other text information can be superimposed on the video signals output from the MONITOR OUT HD SDI and SD SDI connectors of the SRPC-1.

Use the TC Setup menu to specify whether to superimpose this information, and to select the position and type of the superimposed text. Select the menu item CHAR(MON) (see page 45) to make settings for text information output from the MONITOR OUT HD SDI connector, and select the menu item CHAR(SD) (see page 46) to make settings for text information output from the MONITOR OUT SD SDI connector.

Information displayed

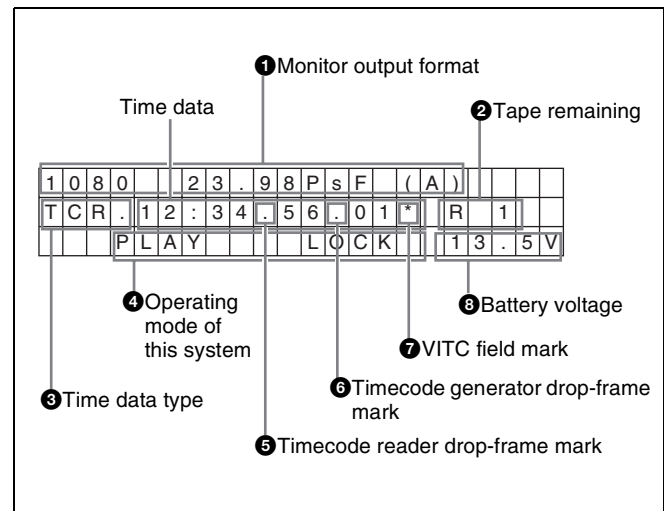

1 Monitor output format

Displays the format of each video signal output from the MON OUT HD SDI connector and the MON OUT SD SDI connector. (This is not the system format.)

The display disappears after a few seconds whenever the unit is in any of the following states.

- When the unit is powered on after changing the system format
- Immediately after pressing the REC button to enter E-E mode
- Immediately after changing the VIDEO >MON SEL(x2) >TYPE setting to “Link A” or “Link B”
- Immediately after setting VIDEO >DC >PD(MON) to “AUTO” or “THRU” (only when the operating frame frequency is 23.98PsF)

2 Tape remaining

The remaining tape capacity is displayed as follows.

Display of remaining tape time when it is 23 minutes or less

```
T C R . 2 3 : 5 9 : 4 0 : 1 8 R 2 3
```

Display of remaining tape time when it is 5 minutes or less

```
T C R . 2 3 : 5 9 : 4 0 : 1 8 R 5
```

3 Time data type

Display	Meaning
CTL	CTL counter data
TCR	LTC reader timecode data
UBR	LTC reader user bit data
TCR.	VITC reader timecode data
UBR.	VITC reader user bit data
TCG	Timecode generator timecode data
UBG	Timecode generator user bit data

When timecode and user bit data cannot be read correctly, asterisks (*) are displayed in these blocks, for example as “T*R”, “U*R”, “T*R.”, and “U*R.”.

4 Operating mode

The information displayed is divided as shown in the following figure into blocks A and B.

Block A: Operating mode

Block B: Servo lock state or tape speed

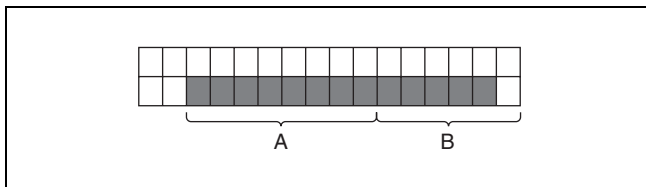

The following modes are shown in the operating mode display.

“SYSTEM READY”
 “CASSETTE OUT”
 “STANDBY OFF”
 “REC”
 “REC LOCK”
 “REC PAUSE”
 “PLAY”
 “PLAY LOCK”
 “PLAY PAUSE”
 “F.FWD”
 “REW”
 “TAPE UNTHREAD”
 “STOP”
 “STANDBY ON”

5 Timecode reader drop-frame mark (525-line mode only)

“.”: Drop-frame mode

“:”: Non-drop frame mode

6 Timecode generator drop-frame mark (525-line mode only)

“.”: Drop-frame mode

“:”: Non-drop frame mode

7 VITC field mark

“ ” (blank): Displaying odd field

“*”: Displaying even field

8 Battery voltage

Displays the battery or AC power voltage.

To display warning/error messages

Set TC Setup menu items CHAR(MON) > MODE and CHAR(SD) > MODE to something other than “TIME”. Next, to display both warnings and error messages, set WARN to “W+E”. To display error messages only set WARN to “ERR”.

The first 16 characters of messages are displayed as flashing characters on the second line.

```
T C R . 2 3 : 5 9 : 4 0 : 1 8
N O E X T E R N A L R E F E
```

The first 16 characters of a warning/error message

See page 75 for more information about warning messages, and see page 72 for more information about error messages.

When two or more warnings or error messages are issued at the same time, each message is repeated twice in flashing characters.

When there are no warnings or error messages, the information selected with the CHAR(MON) > MODE and CHAR(SD) > MODE menu items is displayed as flashing characters on the second line.

To change the position of superimposed text

You can move the position of superimposed text in 16 steps horizontally (0 to 15) and 24 steps vertically (0 to 23).

To set the values, use CHAR(MON) > HPOS/VPOS or CHAR(SD) > HPOS/VPOS in the TC Setup menu.

3-7 Handling Cassettes

3-7-1 Usable Cassettes

This system uses 1/2-inch width HDCAM-SR S-size cassettes.

The maximum recording times are as follows.

System frequency	Maximum recording time
29.97 Hz	40 minutes (20 minutes for double-speed recording)
25 Hz	48 minutes (24 minutes for double-speed recording)
23.98 Hz/24Hz	50 minutes (25 minutes for double-speed recording)

Note

Use this unit (SRW-1) or a SRW-5000/5500 unit to rewind tapes. Do not use cassettes which have been rewound by other units or by rewinders.

Storage of cassettes

Store your cassettes at room temperature and normal humidity.

3-7-2 Inserting and Ejecting Cassettes

Check to be sure that the system is powered on before inserting and ejecting cassettes.

Note

To protect tapes, do not power the SRW-1 off with a cassette loaded. Always eject the cassette first, and then use the following procedure to power the system off.

To insert cassettes

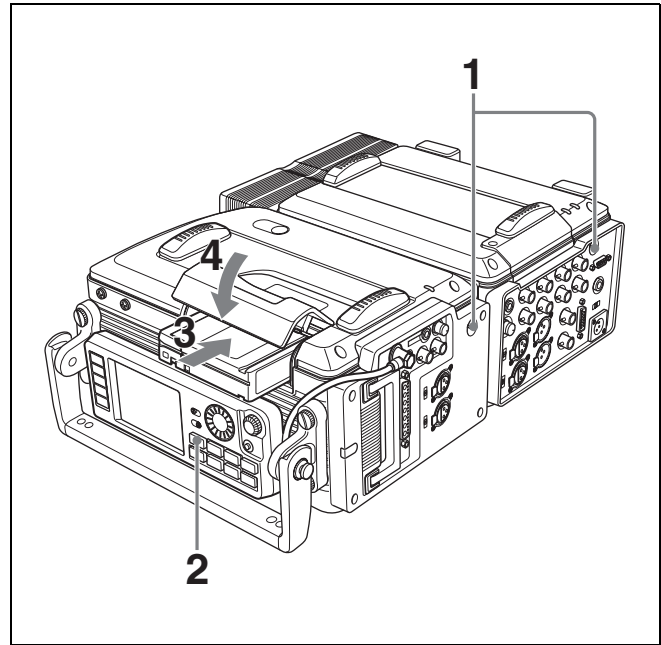

1 Set the SRW-1 and SRPC-1 POWER ON/OFF switches to ON.

2 Press the EJECT button.

The cover of the cassette insertion slot opens.

3 Check the following, and then insert the cassette.

- There is no slack in the tape. (If there is slack in the tape, see “Removing slack in the tape”.)
- There is no error message in the display (see page 72).

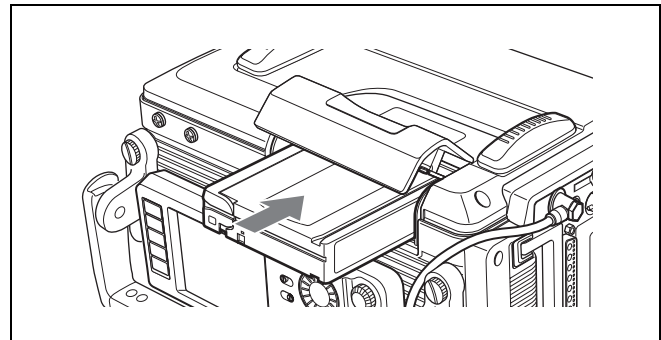

4 Press the cover of the cassette insertion slot to close it.

The tape is wound on the drum.

If “VTR 007F: HUMID ERROR” appears in the display

Condensation was detected.

See “Condensation” (page 69) for the steps to take.

Removing slack in the tape

Carefully rotate one of the reels in the direction of the arrow until it stops.

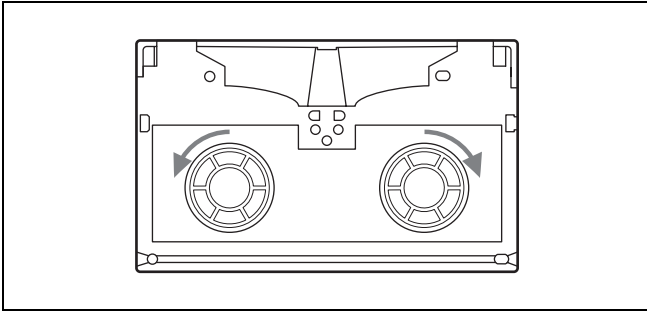

To eject cassettes

With the system powered on, press the EJECT button on the control panel.

The tape is unthreaded and the cassette is automatically ejected. This operation takes a few seconds.

To cancel the ejection before it is finished, press any of the other operation buttons before the cassette is completely ejected. The cassette ejection operation is canceled and the operation corresponding to the button you pressed starts.

To remove a cassette with the system powered off

Proceed as follows if you need to remove a cassette with the SRW-1 powered off, because the battery pack is exhausted or for some other reason.

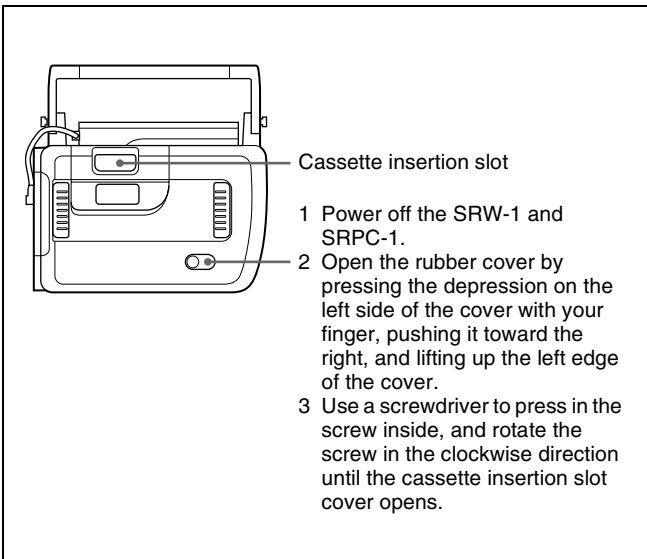

There is no need to return the screw to its original position after you remove the cassette. Normal operation resumes again the next time you power the system on.

For the method of ejecting the cassette after a slack error (forcible eject), refer to the Maintenance Manual.

3-7-3 Preventing Accidental Erasure

To prevent accidental erasure of material recorded on a tape, push in the record-protect plug.

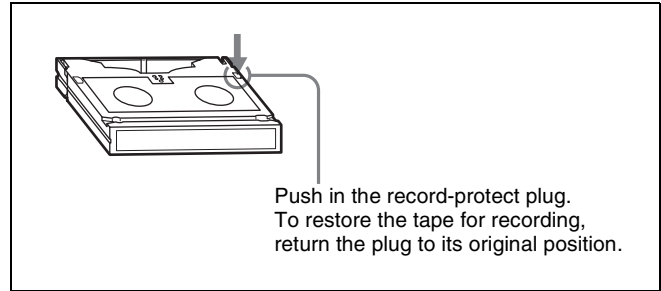

When a cassette with the plug in this position is inserted into the recorder, the REC INHI indicator lights up on the control panel display and recording will not start, even if you press the REC and PLAY buttons.

To restore the tape for recording, return the plug to its original position.

3-8 Power Saving Mode

You can extend the battery operation time by turning off unused output signals to reduce recording and playback power consumption.

To do this, set the MODE, SDI OUT, MON, SD items under POWER in the SYSTEM Setup menu (*see page 52*).

4-1 Basic Menu Operations

4-1-1 Displaying Menus

The menu system of the joined SRW-1/SRPC-1 consists of four setup menus.

- TC Setup menu (see page 43)
- VIDEO Setup menu (see page 47)
- AUDIO Setup menu (see page 48)
- SYSTEM Setup menu (see page 50)

To display menus

Press the menu button (TC, VIDEO, AUDIO, or SYSTEM) corresponding to the menu that you want to display.

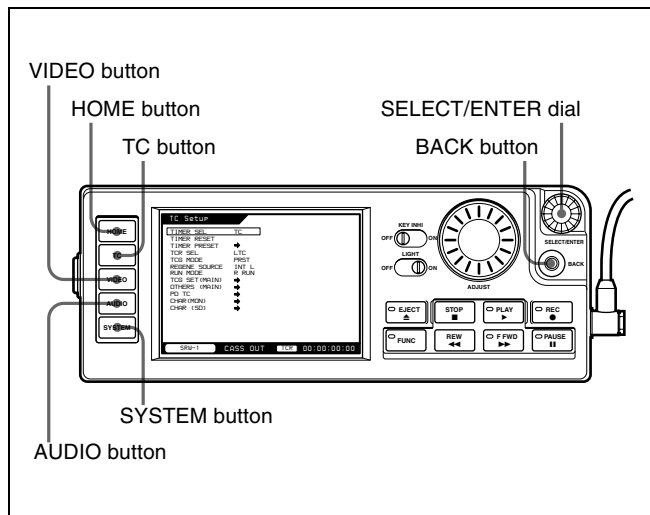

To return to the HOME screen

Press the HOME button or repeatedly press the BACK button. (See the previous figure.)

4-1-2 Changing Menu Settings

- 1 Rotate the SELECT/ENTER dial to move the cursor to the target item.

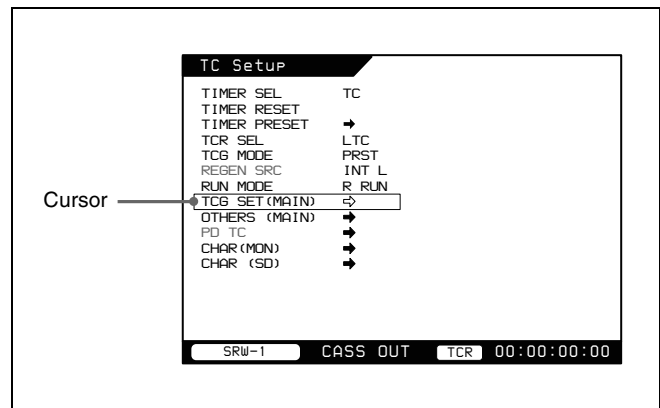

- 2 Press the SELECT/ENTER dial.

A submenu window opens for the selected item. If the selected item is a command, the command is executed.

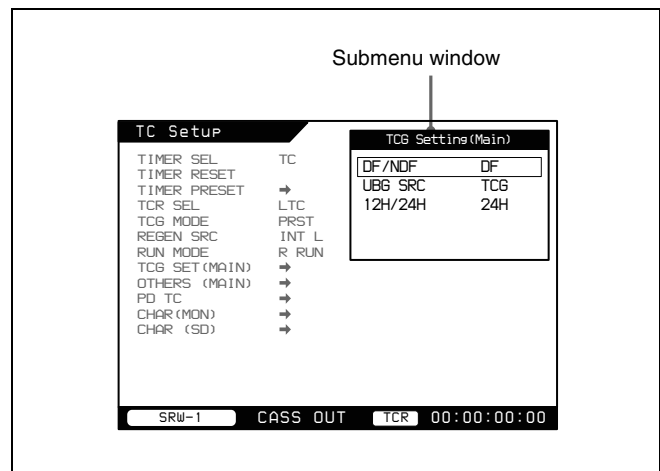

- 3 Rotate the SELECT/ENTER dial to select the desired setting in the submenu window.

A setting window opens.

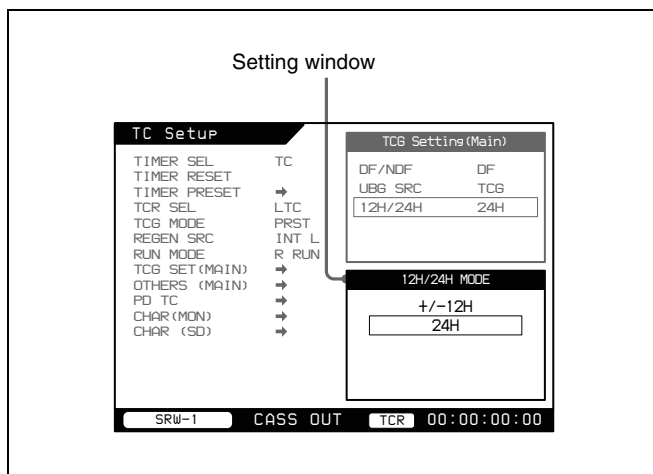

- 4 Rotate or press the SELECT/ENTER dial to select the desired setting.

To return to an upper level

Press the BACK button.

4-2 TC Setup Menu

The TC (timecode) Setup menu allows you to make settings related to timecode.

In the Settings column of the following table:

- Default settings are underlined.
- Square brackets indicate settings as displayed in setting windows (see the figure for step **3** on page 55).

Item	Settings
TIMER SEL	Selects the type of time data to use. CTL [CTL]: Display the tape running time in Hours:Minutes:Seconds format. <u>TC [TC]</u> : Display timecode. UBIT [UBIT]: Display user bits.
TIMER RESET	Resets the internal timecode generator. Time data is displayed as 00:00:00:00 (timecode) or 00 00 00 00 (user bits). Notes <ul style="list-style-type: none"> • The values read by the timecode reader cannot be reset. • The timecode generator cannot be reset when it is locked to external timecode or to the values read by the internal timecode reader.
TIMER PRESET	Selects the type of time data to preset to an arbitrary value. TCG TC: Timecode generated by the timecode generator TCG UBIT: User bits generated by the timecode generator CTL: CTL signal count
TCR SEL	Selects the type of timecode which you want the internal timecode reader to read during playback. AUTO [Auto]: Read VITC when the playback speed is less than $\pm 1/2$ times normal speed, and LTC when the playback speed is more than $\pm 1/2$ times normal speed. <u>LTC [LTC]</u> : Read LTC. VITC [VITC]: Read VITC.
TCG MODE	Selects the type of timecode to which the internal timecode generator synchronizes. <u>PRST [Preset]</u> : Synchronizes to a preset value. You can use the TIMER PRESET item to preset the initial value of the timecode generated by the internal timecode generator. RGN [Regen]: Synchronizes to the timecode selected in the following item REGENE SOURCE (regenerate).
REGENE SOURCE	Selects the timecode to be regenerated by the internal timecode generator. <u>INT L [Internal LTC]</u> : Timecode recorded in the longitudinal direction on the tape EXT L [External LTC]: Timecode input to the TC IN connector SDI-L [SDI LTC]: Video signal LTC time data input to the HD SDI IN A/B connectors SDI V [SDI VITC]: Video signal VITC input to the HD SDI IN A/B connectors
RUN MODE	Selects the timecode generator run mode. F RUN [Free Run]: Timecode advances without pause from the time that the system is powered on. <u>R RUN [Rec Run]</u> : Timecode advances only during recording.

Item		Settings
TCG SET(MAIN) Timecode generator settings for the main timecode Note These settings are valid only when the TCG MODE item is set to PRST.	DF/NDF (Valid only when the frame frequency of this system is 29.97 Hz)	Selects the frame count mode. <u>DF [Drop Frame]</u> : Drop-frame mode NDF [Non Drop Frame]: Non-drop frame mode
	UBG SOURCE	Selects the source timecode of user bits. <u>TCG [TCG Source]</u> : The same source as the source of the internal timecode generator INT [Internal]: Timecode generated by the timecode generator. Arbitrary user bits settings (see page 62) are possible, regardless of the “TCG” setting.
	12H/24H	Selects the CTL display mode. 12H [+/-12H]: 12-hour display mode 24H [24H]: 24-hour display mode Note When +/-12H display is selected, the tens digit of the hours value is dropped for values less than 10.
OTHERS(MAIN) Other settings related to main timecode	TC OUT	Selects the timecode output from the TC OUT connector. <u>AUTO [Auto]</u> : During playback, timecode read by the internal timecode reader. During recording (including E-E mode), timecode generated by the timecode generator is output, delayed by 1 frame. (This maintains synchronization with the output video). TCG [TCG]: Timecode generated by the timecode generator is output, delayed by 1 frame. (This maintains synchronization with the output video). THRU [Through]: Through output of timecode input to the TC IN connector TCG (No Delay): Timecode generated by the timecode generator is output, with no delay. (The timecode is out of synchronization with the output video, being 1 frame in advance of the video.) Select this setting when you want to synchronize other devices, using the timecode generator of this unit as the master.
	RT REC	Selects whether or not to record the real time in user bits (see page 62). <u>OFF [Off]</u> : Do not record. VITC [VITC UB]: Record in VITC. V+L [VITC UB+LTC UB]: Record in VITC and LTC. LTC [LTC UB]: Record in LTC.
	RT SET	Sets the real time.
	LTC Delay	Sets the phase difference between the timecode generator and the LTC input from the TC IN connector. <u>0 [NO Delay]</u> : Same timing +1F [+1F Delay]: The generator is delayed by 1 frame
	VITC Delay	Sets the phase difference between the timecode generator and the LTC/VITC timecode of the video signal input from the HD SDI IN A/B connectors. <u>0 [NO Delay]</u> : Same timing +1F [+1F Delay]: The generator is delayed by 1 frame
PD TC Settings related to pulldown timecode	TC PRESET	Presets pulldown timecode.
	DF/NDF	Selects the frame count mode for pulldown timecode to preset. <u>DF [Drop Frm]</u> : Drop-frame mode NDF [Non Drop Frm]: Non-drop frame mode

Item		Settings
CHAR(MON) The style of text information superimposed on the output of the MONITOR OUT HD SDI connector	ON/OFF	Selects whether to output text information. <u>ON</u> [On]: Output. <u>OFF</u> [Off]: Do not output.
	HPOS	Sets the horizontal display position of text information. 0 to 15 (<u>8</u>)
	VPOS	Sets the vertical display position of text information. 0 to 23 (<u>21</u>)
	TYPE	Selects the character type. W/O [Without BG]: White characters with no background OUTL [Outline]: White characters outlined in black TRNS [Translucent]: White characters on a gray screen background BG [With BG]: White characters on a black background
	SIZE	Set the size of characters. ×1 [×1]: Normal size ×2 [×2]: Twice normal size
	MODE	Selects the content of text information. +STAT [Time + Status]: Timecounter display information and status information +UB [Time + User Bits]: Timecounter display information and user bit data +CTL [Time + CTL]: Timecounter display information and CTL +VITC [Time + VITC]: Timecounter display information and VITC TIME [Time only]: Timecounter display information only
	WARN	When the MODE item is set to other than TIME, selects whether to display warning/error messages as flashing characters on the second line. <u>OFF</u> [Off]: Do not display. <u>ERR</u> [Error]: Display error messages. <u>W+E</u> [Warn + Error]: Display warning and error messages.
	TAPE	Selects whether to display tape remaining time. <u>OFF</u> [Off]: Do not display. <u>ON</u> [On]: Display.
	BATT	Selects whether to display remaining battery power. <u>OFF</u> [Off]: Do not display. <u>ON</u> [On]: Display.

Item		Settings
CHAR(SD) The style of text information superimposed on the output of the MONITOR OUT SD SDI connector	ON/OFF	Selects whether to output text information. ON [On]: Output. OFF [Off]: Do not output.
	HPOS	Sets the horizontal display position of text information. 0 to 15 (g)
	VPOS	Sets the vertical display position of text information. 0 to 23 (21)
	TYPE	Selects the character type. W/O [Without BG]: White characters with no background OUTL [Outline]: White characters outlined in black TRNS [Translucent]: White characters on a gray screen background BG [With BG]: White characters on a black background
	SIZE	Set the size of characters. ×1 [×1]: Normal size ×2 [×2]: Twice normal size
	MODE	Selects the content of text information. +STAT [Time + Status]: Timecounter display information and status information +UB [Time + User Bits]: Timecounter display information and user bit data +CTL [Time + CTL]: Timecounter display information and CTL +VITC [Time + VITC]: Timecounter display information and VITC TIME [Time only]: Timecounter display information only
	WARN	When the MODE item is set to other than TIME, selects whether to display warning/error messages as flashing characters on the second line. OFF [Off]: Do not display. ERR [Error]: Display error messages. W+E [Warn + Error]: Display warning and error messages.
	TAPE	Selects whether to display tape remaining time OFF [Off]: Do not display. ON [On]: Display.
	BATT	Selects whether to display remaining battery power. OFF [Off]: Do not display. ON [On]: Display.

4-3 VIDEO Setup Menu

The VIDEO Setup menu allows you to make settings related to video signals.

In the Settings column of the following table:

- Default settings are underlined.
- Square brackets indicate settings as displayed in setting windows (see the figure for step **3** on page 55).

Item		Settings
PD(MON)	OUTPUT	Selects whether to perform pulldown conversion of output to the MONITOR OUT HD SDI connector <u>AUTO</u> [Auto]: Convert when the frame frequency is 23.98 Hz. Otherwise, do not convert. THRU [Through]: Do not convert.
DC	TYPE	Selects the downconvert mode. <u>LB</u> [Letter Box]: Letter Box mode EC [Edge Crop]: Edge Crop mode SQ [Squeeze]: Squeeze mode
	POS(EC)	When TYPE is set to EC, adjusts the H crop (horizontal width of extracted sections in Edge Crop mode) of downconverter output. -120 to 120 (Q)
MON SEL(x2)	TYPE	When 4:2:2 DUAL STREAM is selected, selects the signal output from the MON OUT HD SDI connector. <u>LINKA</u> [Link-A]: E-E output of the signal input from the HD SDI IN A connector, or playback output of the recorded signal LINKB [Link-B]: E-E output of the signal input from the HD SDI IN B connector, or playback output of the recorded signal
VIDEO I/O	VA INPUT	Selects the input interface. CAM [CAM(Optical)]: CAMERA connector (only when optional HKSR-101 is installed) SDI [SDI Input]: HD SDI IN A/B connectors
	CAM TYPE	Selects the type of connected camera, when CAM is selected under VA INPUT. <u>F950</u> [F950]: When using the HDC-F950. STD [Standard]: When using a recommended optically-connectable camera. <i>Contact your Sony service representative for details about optically-connectable cameras.</i>

4-4 AUDIO Setup Menu

The AUDIO Setup menu allows you to make settings related to audio signals.

In the Settings column of the following table:

- Default settings are underlined.
- Square brackets indicate settings as displayed in setting windows (see the figure for step **3** on page 55).

Item	Settings
INPUT SEL Input signal selection	TRACK1 Selects the signal to assign to track 1. <u>SDI1</u> [<u>SDI CH1</u>] to SDI12 [<u>SDI CH12</u>], ANA1 [Analog CH1] to ANA4 [Analog CH4], A/E7 [AES/EBU 7] to A/E10 [AES/EBU 10]
	TRACK2 Selects the signal to assign to track 2. Same settings as TRACK1 (<u>SDI2</u>)
	TRACK3 Selects the signal to assign to track 3. Same settings as TRACK1 (<u>SDI3</u>)
	TRACK4 Selects the signal to assign to track 4. Same settings as TRACK1 (<u>SDI4</u>)
	TRACK5 Selects the signal to assign to track 5. Same settings as TRACK1 (<u>SDI5</u>)
	TRACK6 Selects the signal to assign to track 6. Same settings as TRACK1 (<u>SDI6</u>)
	TRACK7 Selects the signal to assign to track 7. Same settings as TRACK1 (<u>SDI7</u>)
	TRACK8 Selects the signal to assign to track 8. Same settings as TRACK1 (<u>SDI8</u>)
	TRACK9 Selects the signal to assign to track 9. Same settings as TRACK1 (<u>SDI9</u>)
	TRACK10 Selects the signal to assign to track 10. Same settings as TRACK1 (<u>SDI10</u>)
	TRACK11 Selects the signal to assign to track 11. Same settings as TRACK1 (<u>SDI11</u>)
	TRACK12 Selects the signal to assign to track 12. Same settings as TRACK1 (<u>SDI12</u>)
PHONE SEL	Selects the audio signals output to the EARPHONES jack and MONITOR OUT L and R connectors.
MIX MODE	Selects the method of mixing audio signals output to the EARPHONES jack and the MONITOR OUT L/R connectors. ADD [Adj]: Simple addition <u>RMS</u> [<u>RMS</u>]: Multiplied average (root mean square) AVG [Average]: Simple average
REC LEVEL	Adjusts the audio recording level. (This adjustment is impossible during playback.)
PB LEVEL	Adjusts the audio playback level. (This adjustment is impossible during recording.)
METER TYPE	Sets the audio level meter display range. <u>PEAK</u> [<u>Full Peak</u>]: Display 0 dBFS as the peak value. REF [Full Ref]: Display the reference level (+4 dBu) as 0 dB. FINE [Fine]: Display a scale with 0.25 dB steps centered around -20 dB.
PEAK HOLD	Selects whether to use the peak hold function. <u>ON</u> [<u>On</u>]: Use. OFF [Off]: Do not use.

Item		Settings
BEEP(PHONE) Level of beep tones	ALARM	Determines whether to generate alarm tones. OFF [Off]: Do not generate alarm tones. HIGH [High]: Generate high-level alarm tones. <u>LOW [Low]</u> : Generate low-level alarm tones.
	WARN	Determines whether to generate warning tones. OFF [Off]: Do not generate warning tones. HIGH [High]: Generate high-level warning tones. <u>LOW [Low]</u> : Generate low-level warning tones.
INPUT DELAY		Sets the audio signal phase recorded on the tape (the target is all audio signal input). <u>0 [NO Delay]</u> : No audio signal delay (use when the phase of the audio signals is the same as the phase of the video signals). +1F [+1F Delay]: Record audio signal with a delay of 1 frame (use when the video signals of external cameras and so on are input with a delay of 1 frame versus audio signals).

4-5 SYSTEM Setup Menu

The SYSTEM Setup menu allows you to make system settings.

In the Settings column of the following table:

- Default settings are underlined.
- Square brackets indicate settings as displayed in setting windows (see the figure for step 3 on page 55).

Item	Settings
FORMAT Signal format settings	LINE Sets the number of effective lines and the scanning system. <u>1080I</u> [1080I] <u>1080P</u> [1080PsF/P] 720P [720P]
	FRAME Sets the frame frequency. <u>23.98</u> [23.98]: Frame frequency 23.976 Hz 24 [24]: Frame frequency 24 Hz 25 [25]: Frame frequency 25 Hz (field frequency 50 Hz) 29.97 [29.97]: Frame frequency 29.97 Hz (field frequency 59.94 Hz) 50 [50]: Frame frequency 50Hz 59.94 [59.94]: Frame frequency 59.94Hz
	SIGNAL Sets the sampling method and video signal recording rate. <u>422</u> [4:2:2]: 4:2:2 (Y/Pb/Pr), 440 Mbps 422x2 [4:2:2 Dual]: 4:2:2 (Y/Pb/Pr) DUAL STREAM, 880 Mbps 444SQ [4:4:4 SQ]: 4:4:4 (R/G/B), SQ mode, 440 Mbps 444HQ [4:4:4 HQ]: 4:4:4 (R/G/B), HQ mode, 880 Mbps Note Tapes recorded with the 444HQ setting cannot be played back on the SRW-5000/5500.
	SELECT FPS When the HKSR-102 is installed, selects whether to use the SELECT FPS function, and the operating mode of the function. OFF [Off]: Do not use the SELECT FPS function. ON [On]: Enables SELECT FPS function with frame rate (FPS) set on camera. DUB [dub(bypass MY)]: Record without using the HKSR-102. (Select this to dub a tape recorded with the SELECT FPS function.) VTR [VTR]: Enables SELECT FPS function with frame rate (FPS) set on the SRW-1. Note When the HKSR-102 is not installed in this unit, the ON and DUB settings have the same effect.
	FPS FORMAT Selects the system format when the SELECT FPS function is enabled. <u>DEF</u> [Default]: Use the default settings. 25 [25] 29/30 [29.97/30] 50 [50] 59/60 [59.94/60] <i>For details, see 5-4 "SELECT FPS Function (Selectable Recording Frame Rate) (When Optional HKSR-102 Is Installed)" (page 66).</i>
REFERENCE Reference signal selection	MODE Selects the input signals to use as reference signal. <u>INP</u> [Input]: Video signals input to the HD SDI IN A/B connectors. EXT [External]: Signals selected with the next item EXTERNAL.
	EXTERNAL When the previous item MODE is set to EXT, selects the signals to use as reference signal. <u>HD</u> [HD]: During playback and audio signal recording, use an HD tri-level sync signal input to the REF IN HD connector. SD [SD]: When the frame frequency is 29.97 Hz or 25 Hz, use a VBS signal input to the REF IN SD connector. HD&SD [HD&SD]: When the frame frequency is 23.98 Hz, use an HD tri-level sync signal input to the REF IN HD connector, and a VBS signal input to the REF IN SD connector.



Item	Settings	
TEST SG Test signal output settings Note Both VIDEO and AUDIO settings return to the default OFF when you power the system off.	VIDEO	Determines whether to make the internal video signal generator generate a test signal. <u>OFF [Off]</u> : Generate no test signal. CB [Color Bar]: Generate a color bar signal. BLK [Black]: Generate a black signal.
	AUDIO	Determines whether to make the internal audio signal generator generate a test signal. Settings for internal audio signal generator <u>OFF [Off]</u> : Generate no test signal. 1KHz [1KHz]: Generate a sine wave signal of 1 kHz. NONE [Silence]: Generate a muted signal.
LCD Display backlight settings	LIGHT OFF	Determines whether to turn the backlight off after a specified interval. <u>DIS [Disable]</u> : Do not turn off. 5sec [5sec]: Turn off after 5 seconds. 10sec [10sec]: Turn off after 10 seconds. 30sec [30sec]: Turn off after 30 seconds. 1min [1min]: Turn off after 1 minute. 3min [3min]: Turn off after 3 minutes. 5min [5min]: Turn off after 5 minutes.
	BRIGHT	Sets the brightness of backlight. 0 to 31 (<u>20</u>)
	SAVER	Determines whether to display a screen saver after a specified interval. <u>DIS [Disable]</u> : Do not display. 1min [1min]: Display after 1 minute. 3min [3min]: Display after 3 minutes. 5min [5min]: Display after 5 minutes. 10min [10min]: Display after 10 minutes. 20min [20min]: Display after 20 minutes. 30min [30min]: Display after 30 minutes. 1hour [1hour]: Display after 1 hour.
	SAVER MSG	Sets a screen saver message.
KEYMAP Key map settings	EJECT EJECT button function	<u>DIS [Disable]</u> : Disable the button. <u>ENA [Enable]</u> : Enable the button.
	STOP STOP button function	
	PLAY PLAY button function	
	REC REC button function	
	REW REW button function	
	FFWD F FWD button function	
	PAUSE PAUSE button function	
KEY INHI Button inhibit settings	ALL [ALL]: Lock all buttons. MAP [MAP]: Lock only buttons which have been disabled with KEYMAP settings.	
REMOTE/LOCAL	Specifies whether the unit is controlled locally or remotely. <u>LCL [Local]</u> : Operate the unit locally from the control panel. RMT [Remote]: Control the unit remotely from the external device connected to the REMOTE IN connector. In this case, the tape transport, EJECT, and FUNC buttons on the unit's control panel follow the KEY MAP settings. (The EJECT button on the top panel of the SRW-1 functions normally.)	

Item		Settings
SERVO	STBY OFF	Sets the time after the tape stops until the system enters tape protect mode. 1sec [1sec]: After 1 second 5sec [5sec]: After 5 seconds 10sec [10sec]: After 10 seconds 20sec [20sec]: After 20 seconds <u>30sec [30sec]</u> : After 30 seconds 40sec [40sec]: After 40 seconds 50sec [50sec]: After 50 seconds 1min [1min]: After 1 minute 2min [2min]: After 2 minutes 3min [3min]: After 3 minutes 4min [4min]: After 4 minutes 5min [5min]: After 5 minutes 6min [6min]: After 6 minutes 7min [7min]: After 7 minutes 8min [8min]: After 8 minutes 30min [30min]: After 30 minutes
	TRACKING	<u>Unity [Unity]</u> : Tracking control does not function during playback. VARI [Variable]: Tracking control functions during playback.
	REC REVIEW	Specifies how the unit performs recording review. <u>NORM [Normal]</u> : Rewind the tape, normally 3 seconds and up to a maximum of 10 seconds, and then play it back. ALL [All]: Rewind the tape to the recording start position, and then play it back.
REC INHI Record inhibit settings		<u>OFF [Off]</u> : Do not inhibit recording. ON [On]: Inhibit recording
EDIT	IN POINT	Set time data to cue up (Mark IN data). (The time data set is displayed in the format "IN: xx:xx:xx:xx" in the time data field of the display.)
POWER Settings to reduce power consumption by limiting output signals or restricting use of output connectors	MODE	Selects output signal mode. <u>EE [EE]</u> : This mode selects EE signals (input signals) for video, audio, and timecode output during tape stop and standby. Select this to record a program or to reduce power consumption. (Usually use this mode.) PB [PB]: This mode selects playback signals for video, audio, and timecode output during tape stop and standby. Select this only to use the SRW-1 as a player under remote control via the RNOTE IN connector.
	SDI OUT	Selects whether to output signals from the HD SDI OUT A/B connectors. <u>ON [On]</u> : Output signals. OFF[Off]: Do not output signals.
	MON	Selects whether to output signals from the MONITOR OUT HD SDI connector. <u>ON [On]</u> : Output signals. OFF[Off]: Do not output signals.
	SD	Selects whether to output signals from the MONITOR OUT SD SDI connector. <u>ON [On]</u> : Output signals. OFF[Off]: Do not output signals.

Item	Settings	
BATTERY Settings relating to remaining battery power display	BATT TYPE	Selects the type of battery to attach to the battery attachment section. AC [AC Adapter] Li-ion [Li-ion Battery] BP-GL [BP-GL Battery]: BP-GL95 OTH1 [Other 1] OTH2 [Other 2]
	N-END(BATT)	For the battery type selected with the previous item BATT TYPE, sets the threshold voltage to issue a “near-end (almost exhausted)” warning. 11.0 to 15.0 (13.0V)
	END(BATT)	For the battery type selected with the previous item BATT TYPE, sets the threshold voltage to issue an “end (exhausted)” warning. 11.0 to 12.0 (11.0V)
	DCIN TYPE	Selects the type of battery to connect to the DC IN connector. AC [AC Adapter] Li-ion [Li-ion Battery] BP-GL [BP-GL Battery]: BP-GL95 OTH1 [Other 1] OTH2 [Other 2]
	N-END(DCIN)	For the battery type selected with the previous item DCIN TYPE, sets the threshold voltage to issue a “near-end (almost exhausted)” warning. 11.0 to 15.0 (11.9V)
	END(DCIN)	For the battery type selected with the previous item DCIN TYPE, sets the threshold voltage to issue an “end (exhausted)” warning. 11.0 to 12.0 (11.0V)
OTHERS	SOFT VERSION	Displays the software version installed in the SRW-1 and SRPC-1. SY CP SV EQ AU
	HOURS METER	Display count values of the digital hours meter (totals since the start of use, or totals during a certain period). SYSTEM: Total system operation time DRUM: Total drum revolution time TAPE: Total tape running time THREAD: Total number of threadings and unthreadings
	FORMAT LIST	Displays a list of supported formats and the currently selected format. You can also change the format.
	OPTION LIST	Displays a list of the installed options.



5-1 Signal Format Settings

5-1-1 Selecting the System Signal Format

Use FORMAT or OTHERS in the SYSTEM Setup menu to select the system signal format.

Note

If a cassette is loaded in the SRW-1, be sure to eject it before starting the following procedure.

To set with FORMAT

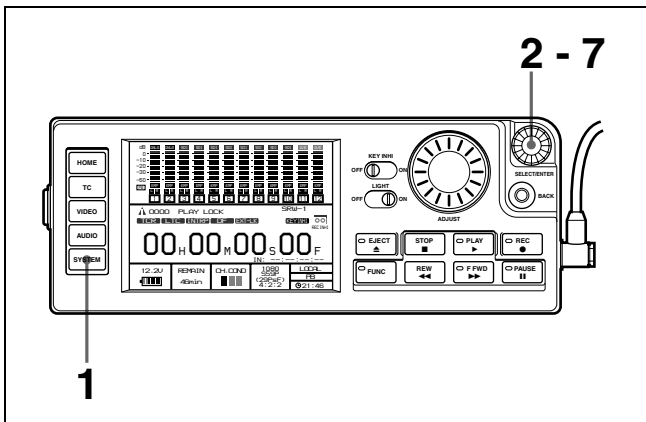

- 1 Press the menu selection button “SYSTEM” on the control panel.
The SYSTEM Setup menu appears.
- 2 Rotate the SELECT/ENTER dial to move the cursor to FORMAT, and then press the dial.
A submenu window appears.

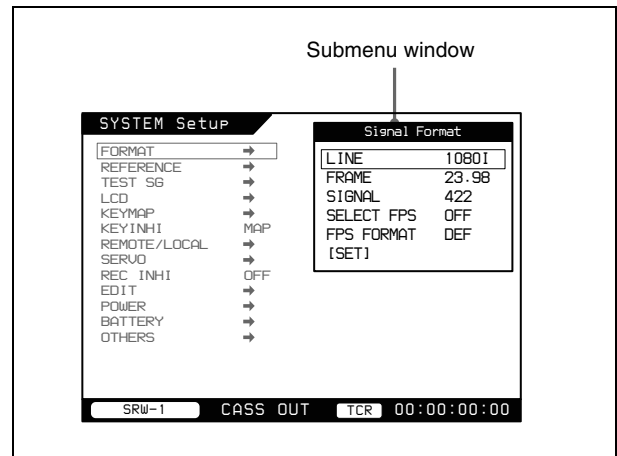

- 3 Rotate the SELECT/ENTER dial to select LINE in the submenu window.

A setting window appears.

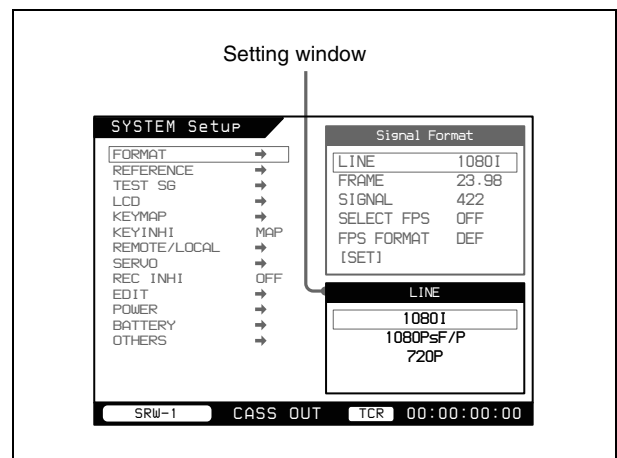

- 4 Select the desired value by rotating and pressing the SELECT/ENTER dial.
This returns you to the submenu window, which is activated again.
- 5 Repeat steps 3 and 4 to set the FRAME and SIGNAL items.

- 6 In the submenu window, select [SET].
- 7 Make sure of the format, and then select [OK].

To set with OTHERS

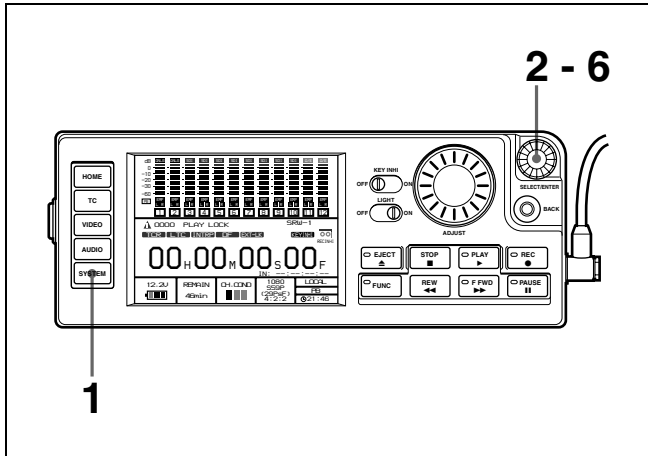

- 1 Press the menu selection button “SYSTEM” on the control panel.
The SYSTEM Setup menu appears.
- 2 Rotate the SELECT/ENTER dial to move the cursor to OTHERS, and then press the dial.
A submenu window appears.

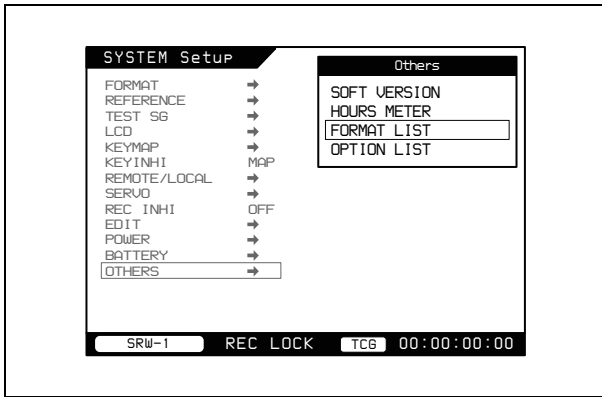

- 3 Rotate the SELECT/ENTER dial and select FORMAT LIST in the submenu window.
The format list screen appears.

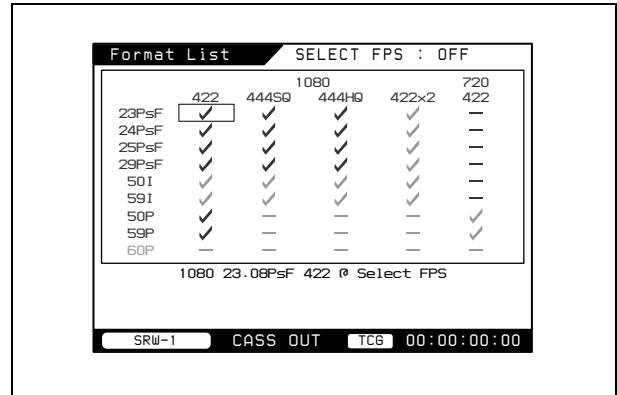

A bar appears for formats that cannot be used. A yellow or green check mark appears for formats that can be used. The check mark is green for formats that can be used when the SELECT FPS function is enabled.

See 5-4 “SELECT FPS Function (Selectable Recording Frame Rate) (When Optional HKSR-102 Is Installed)” (page 66) for more information about the SELECT FPS function.

- 4 Move the cursor to the format you want to use.

To move the cursor left and right
Rotate the SELECT/ENTER dial.

To move the cursor up and down
Rotate the SELECT/ENTER dial while holding down the FUNC button.

- 5 Press the SELECT/ENTER dial.
“CANCEL” and “OK” appear at the bottom of the screen.
- 6 Move the cursor to “OK”, and then press the SELECT/ENTER dial.

A message appears to inform you that the format has been selected, and you return to the HOME screen.

Relation between recording and playback signals and output signals to video monitors

Signals in the formats shown in the following table are output to the HD video monitor connected to the MONITOR OUT HD SDI connector and to the SD monitor connected to the MONITOR OUT SD SDI connector.

Recording/playback signal		HD monitor Output		SD monitor Output
1080/4:2:2	23.98PsF	1080/4:2:2	23.98PsF ^{c)}	525/59.94i
			59.94i ^{d)}	
	24PsF		24PsF ^{e)}	–
	25PsF		25PsF	625/50i
	29.97PsF		29.97PsF	525/59.94i
	50i		50i	625/50i
	59.94i		59.94i	525/59.94i
	50P		50P	625/50i
59.94P	59.94P	525/59.94i		
1080/4:4:4SQ 1080/4:4:4HQ 1080/4:2:2DUAL ^{a)}	23.98PsF	1080/4:2:2	23.98PsF ^{c)}	525/59.94i
			59.94i ^{d)}	
	24PsF		24PsF ^{e)}	–
	25PsF		25PsF	625/50i
	29.97PsF		29.97PsF	525/59.94i
	50i		50i	625/50i
59.94i	59.94i	525/59.94i		
720/4:2:2 ^{b)}	50P	720/4:2:2	50P	–
	59.94P		59.94P	–

a) 1080/4:2:2 DUAL STREAM HD monitor output and SD monitor output can be switched by selected “Link-A” or “Link-B” under MON SEL(x2) in the VIDEO Setup menu.

b) No SD monitor output.

c) When PD(MON) > OUTPUT is set to THRU in the VIDEO Setup menu.

d) When PD(MON) > OUTPUT is set to AUTO in the VIDEO Setup menu.

e) Pulldown is not supported.

To check the signals output to the video monitors

With the FUNC button on the control panel held down, press the HOME button.

The display at the bottom of the HOME screen changes to show the formats of the signals currently being output to the HD and SD video monitors.

When superimposed text is displayed on the video monitors, the signal formats are also displayed on the video monitors for a few seconds after the REC button on the control panel is pressed to output an E-E picture (*see page 36*).

5-1-2 TeleFile Recording

This system records the following TeleFile data to cassette labels with each recording operation.

- IN (recording start point)
- OUT (recording end point)

- Tape format
- Duration (time from In point to Out point)
- File name (automatically assigned file name in the format HDCAMSR_00X)

Note

TeleFile data may not be saved correctly if the POWER ON/OFF switch is set to the OFF position within one second after the end of recording.

When the number of files exceeds 70

Old files are deleted before new files are added.

To delete all or selected files, use the SRW-5000/5500 to format the memory label or carry out a file deleting operation.

5-2 Recording Preparations and Operations

Before recording, make the following preparations.

About connections for recording, see page 27.

Operation	Menu item or control	Reference
Select the recording source input to the SRPC-1 (when the optional HKSR-101 is installed).	VIDEO I/O in the VIDEO Setup menu	Page 58
Select whether or not to perform pull-down conversion for the output to the HD monitor. ^{a)}	PD(MON) in the VIDEO Setup menu	Page 58
Select the audio signals to record.	INPUT SEL in the AUDIO Setup menu	Page 59
Make settings for audio signals to monitor.	PHONE SEL in the AUDIO Setup menu	Page 59
Set the audio level meter display range.	METER TYPE in the AUDIO Setup menu	Page 60
Set the recording audio level.	REC LEVEL in the AUDIO Setup menu	Page 60
Adjust the level of audio signals output to the EARPHONES jack.	Rotate the LEVEL knob of the EARPHONES jack.	Page 17 Page 20
Cancel record inhibit if the system is set to record inhibit mode.	REC INHI in the SYSTEM Setup menu	Page 63
Select the type of time data to display.	TIMER SEL in the TC Setup menu	Page 61
Make settings for the timecode generator depending on timecode and user bit data to record.	RUN MODE, TCG MODE, REGENE SOURCE in the TC Setup menu	Page 61

a) This selection is possible only when the frame frequency is 23.98PsF.

5-2-1 Selecting the Video Input To Record (When Optional HKSR-101 Is Installed)

When the optional HKSR-101 is installed in this unit, select the input from the CAMERA connector (optical-

fiber connector) or the input from the HD SDI IN A/B connectors.

- 1 Press the menu selection button “VIDEO”.
The VIDEO Setup menu appears.
- 2 Rotate the SELECT/ENTER dial to select “VIDEO I/O”, and press the dial.
A settings window appears.
- 3 Rotate the SELECT/ENTER dial to select one of the following, and press the dial.

CAM(Optical): Use the input signal from the CAMERA connector.

SDI Input: Use the input signal from the HD SDI IN A/B connectors.

5-2-2 Selecting Signals to Output to the HD Monitor

Before recording video, first check it on the monitor. When the frame frequency is 23.98PsF, in the VIDEO Setup menu, select whether or not to perform pulldown conversion for the output to the MONITOR OUT HD SDI connector.

- 1 Press the menu selection button “VIDEO.”
The VIDEO Setup menu appears.

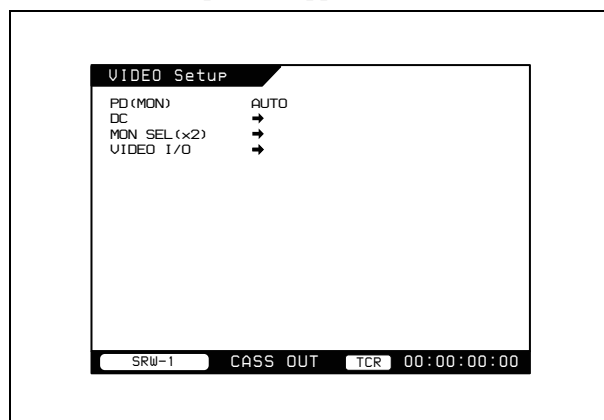

- 2 Rotate the SELECT/ENTER dial to select PD(MON), then press the dial.
A setting window appears.
- 3 Rotate the SELECT/ENTER dial to select one of the following, then press the dial.

AUTO: Pulldown conversion is performed if the frame frequency is 23.98 Hz. Otherwise pulldown conversion is not performed.

THRU: Pulldown conversion is not performed.

5-2-3 Making Audio Signal Settings

Use the AUDIO Setup menu to make settings related to audio signals.

To display the AUDIO Setup menu

Press the menu selection button “AUDIO.”

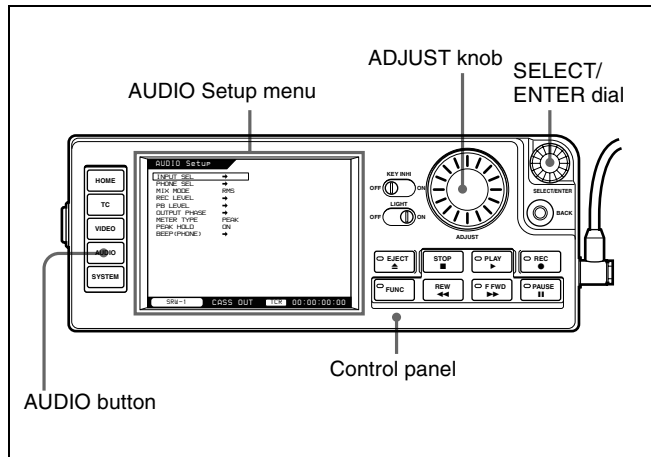

To select audio signals to record

The INPUT SEL item allows you to select the audio signals to record on each track.

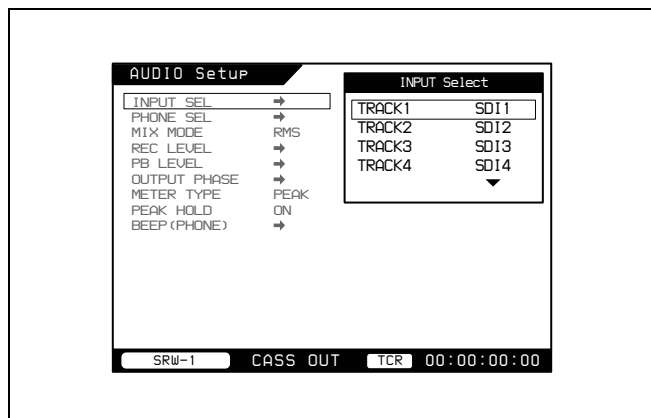

- 1 Rotate the SELECT/ENTER dial to select a track (TRACK1 to TRACK12).
- 2 Press the SELECT/ENTER dial.
- 3 Rotate the SELECT/ENTER dial to select the signal to record on the track selected in steps 1 and 2.

SDI1 to SDI12: SDI signal input to the HD SDI IN A connector

ANA1 to ANA4: Analog audio signal input to the AUDIO INPUT CH-1 and CH-2 connectors on the SRW-1 or the AUDIO INPUT CH-3 and CH-4 connectors on the SRPC-1

A/E7 to A/E10: Digital audio signal input to the AES/EBU INPUT CH7/8 and CH9/10 connectors

- 4 Press the SELECT/ENTER dial.
- 5 Repeat steps 1 and 2 to select other tracks and steps 3 and 4 to select other signals.

To select audio signals to monitor

The PHONE SEL item allows you to select the audio signals to output to the MONITOR OUT L/R connectors and the EARPHONES jacks for the individual channels.

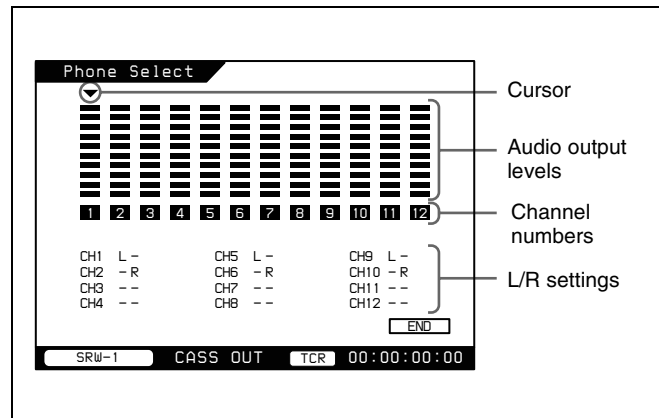

- 1 Rotate the SELECT/ENTER dial to select a channel (1 to 12).
- 2 Press the SELECT/ENTER dial.

The L/R setting of the selected channel changes in the order L → R → LR → none.

Select “none” if you do not want to output the selected channel to the EARPHONES jack. Select LR if you want to output the channel from both sides.

- 3 Repeat steps 1 and 2 to select other channels and steps 3 and 4 to make L/R settings for those channels.
- 4 When you are finished, rotate the SELECT/ENTER dial to select END, and press the dial.

To select the digital audio signal mixing method

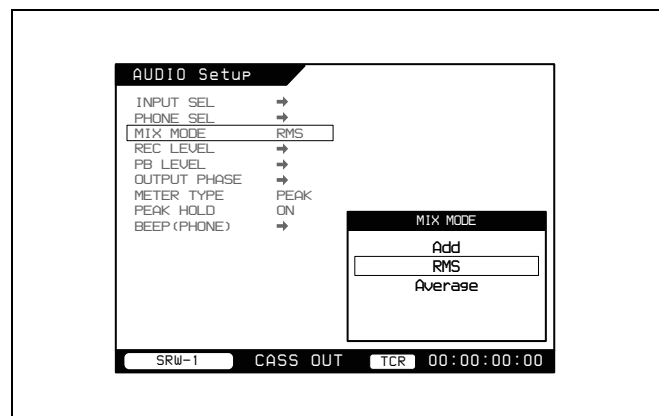

- 1 Rotate the SELECT/ENTER dial to select the mixing method.

ADD: Simple addition

RMS: Multiplied average (room mean square)

Average: Simple average

- 2 Press the SELECT/ENTER dial.

5-2-4 Setting Recording Audio Levels

To check recording audio levels, use the audio level meters in the control panel display. The display switches automatically between recording audio levels during recording and playback audio levels during playback.

To set the display range of the audio level meters

The METER TYPE item allows you to set the display range of the audio level meters.

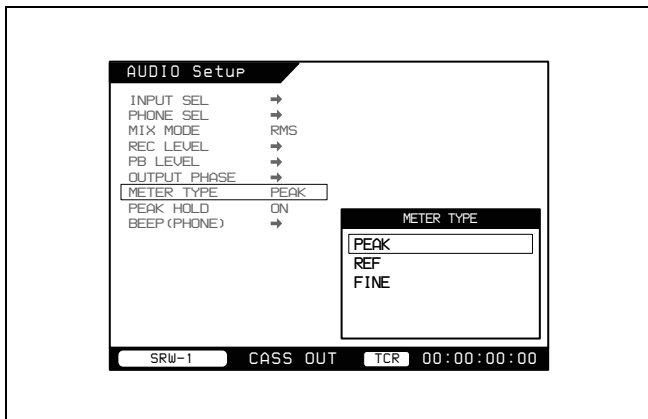

- 1 Rotate the SELECT/ENTER dial to select the scale to display.

Full Peak: Display 0 dBFS as the peak value.

Full Ref: Display the reference level (+4 dBu) as 0 dB.

Fine: Display a scale with steps of 0.25 dB centered around -20 dB.

- 2 Press the SELECT/ENTER dial.

To set recording audio levels

The REC LEVEL setting window allows you to set recording audio levels for the individual channels.

Note

Recording levels cannot be set during playback.

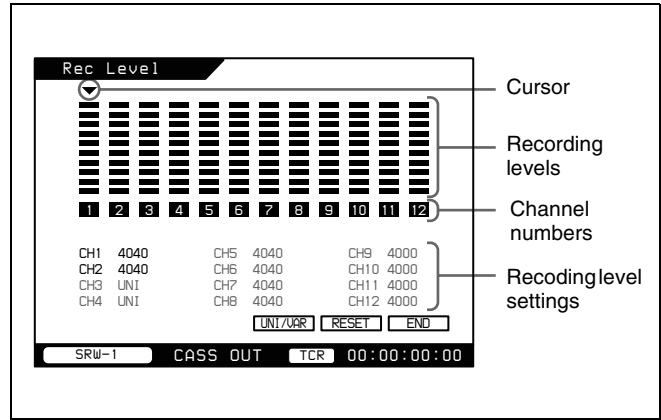

- 1 Rotate the SELECT/ENTER dial to select a channel (1 to 12).

- 2 Press the SELECT/ENTER dial.

The current recording level of the selected channel is shown as a hexadecimal number. UNI is shown for channels whose recording levels have not been changed.

- 3 Rotate the SELECT/ENTER dial to select UNI/VAL, and press the dial.

If you do not need to change the recording level, set the recording level of the channel selected in steps 1 and 2 to UNI and proceed to step 5. If you do need to change the recording level, set the recording level of the channel selected in steps 1 and 2 to VAR and proceed to step 4.

- 4 Rotate the ADJUST knob to set the recording level.

Rotate clockwise to raise the level and rotate counterclockwise to lower it.

To reset the setting

Rotate the SELECT/ENTER dial to move the cursor to RESET, and press the dial.

- 5 Press the SELECT/ENTER dial.
- 6 Repeat steps 1 and 2 to select other channels and steps 3 and 4 to set the recording levels of those channels.
- 7 When you are finished, rotate the SELECT/ENTER dial to select END, and press the dial.

5-2-5 Making Timecode and User Bits Settings

Use the TC Setup menu to make timecode and user bits settings.

To display the TC Setup menu
Press the menu selection button “TC.”

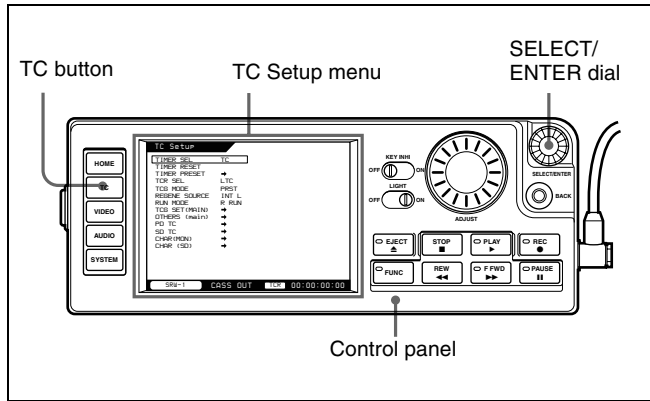

To select the type of time data to display
Use the TIMER SEL item.

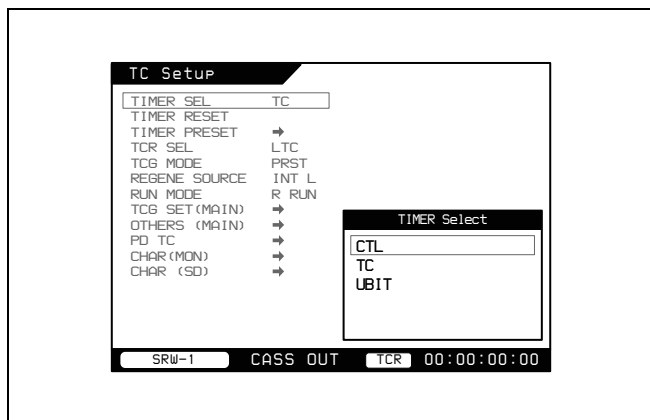

1 Rotate the SELECT/ENTER dial to select CTL, TC (timecode), or UBIT (user bits).

- CTL:** Display CTL signals.
- TC:** Display timecode.
- UBIT:** Display user bit data.

2 Press the SELECT/ENTER dial.

To select timecode to record

You can select the following types of timecode.

Menu item		Timecode
TCG MODE	REGENE SOURCE	
PRST	—	An arbitrary initial timecode value can be preset (R RUN/F RUN and DF/NDF menu items can be set to any values).

Menu item		Timecode
TCG MODE	REGENE SOURCE	
RGN	INT L	Timecode in synchronization with the timecode recorded in the longitudinal direction on the tape.
	EXT L	Timecode in synchronization with the timecode input to the TC IN connector.
	SDI L	Timecode in synchronization with the LTC timecode of the video signal input to the HDI SDI IN A/B connectors.
	SDI V	Timecode in synchronization with the VITC timecode of the video signal input to the HDI SDI IN A/B connectors.

To select user bits to record

You can select the following types of user bits.

Menu item			User bits
Other (MAIN) > RT REC	TCG SET (Main) > UGB SOURCE	TCG MODE	
OFF	TCG	PRST	Arbitrary user bits can be preset (TIMER PRESET > TCG UBIT).
		RGN	Regenerate the user bits of the timecode selected with REGEN SOURCE.
	INT	—	Arbitrary user bits can be preset, regardless of the setting of TCG MODE (TIMER PRESET > TCG UBIT).
VITC	—	—	Record real time in the user bits of VITC only (LTC user bits follow the setting of UGB SOURCE).
V+L	—	—	Record real time in the user bits of both VITC and LTC.
LTC	—	—	Record real time in the user bits of LTC only (VITC user bits follow the setting of UGB SOURCE).

To record timecode

You can use either of the following methods to record timecode.

- Initialize the internal timecode generator with an arbitrary initial value, and record the output of the timecode generator.

- Record the output of the timecode generator synchronized with external timecode or timecode recorded in the longitudinal direction on the tape.

To preset an arbitrary initial timecode value

Set the TCG MODE menu item to PRST, then proceed as follows.

- 1 Select TIMER PRESET > TCG TC.

A preset value setting screen appears.

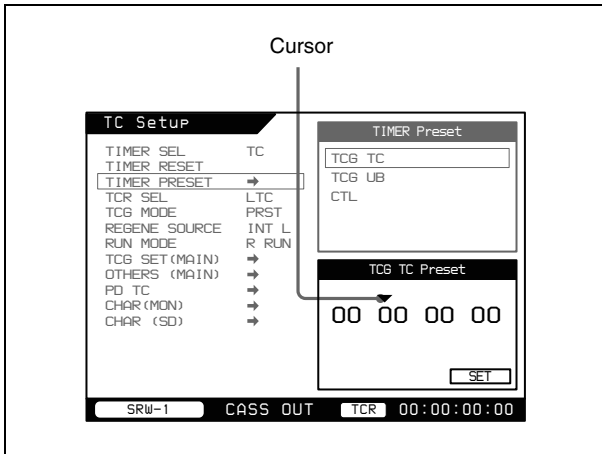

- 2 Rotate the SELECT/ENTER dial to select the digit that you want to modify, then press the dial.
- 3 Rotate the SELECT/ENTER dial to modify the value of the selected digit, then press the dial.

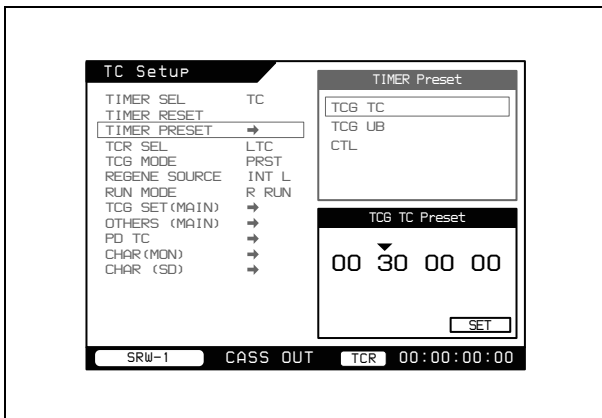

- 4 Repeat steps 2 and 3 to set the values of all digits.
- 5 Rotate the SELECT/ENTER dial to move the cursor to SET, then press the dial.

If RUN MODE is set to F RUN, the timecode starts advancing immediately.

To set all digits to 0

Reset the timecode value with the TIMER RESET menu item. Rotate the SELECT/ENTER dial to select TIMER RESET, then press the dial.

To synchronize the internal timecode generator to external timecode

Use the following method to synchronize the timecode generators of multiple VTRs.

Set the TCG MODE menu item to RGN, then use REGENE SOURCE to select the signal which the timecode generator should regenerate.

To record user bits

By setting user bits, you can record up to eight hexadecimal digits of information (date, time, etc.) in timecode tracks.

To record user bits after setting an arbitrary value

Set Others (MAIN) > RT REC to OFF.

To initialize user bits to an arbitrary value, set the TCG SET (MAIN) > UBG SOURCE menu item to INT. (The TCG MODE menu item can be set to any value.)

Alternatively, set the TCG MODE menu item to PRSET. (The TCG SET (MAIN) > UBG SOURCE menu item can be set to any value.) (See the table in “To select user bits to record” (page 61).)

To set the user bit value, proceed as described in “To preset an arbitrary initial timecode value”. As with timecode, all digits in user bit values can be set to 0 by using the TIMER RESET menu item.

To record real time in user bits

Select the recording method with Others (MAIN) > RT REC (VITC only, both VITC and LTC, or LTC only). Regardless of the setting of TCG SET (MAIN) > UBG SOURCE, real time is recorded in the specified location.

To set the real time to record, proceed as follows.

- 1 Rotate the SELECT/ENTER dial to select RT SET, and press the SELECT/ENTER dial.
The real time setting window appears.
- 2 Rotate the SELECT/ENTER dial to move the cursor to the digit you want to change, and press the dial.
- 3 Rotate the SELECT/ENTER dial to change the value of the selected digit, and press the dial.
- 4 Repeat steps 2 and 3 until the desired value is displayed.
- 5 Rotate the SELECT/ENTER dial to move the cursor to SET, and press the SELECT/ENTER dial.

5-2-6 Recording Operations

Proceed as follows.

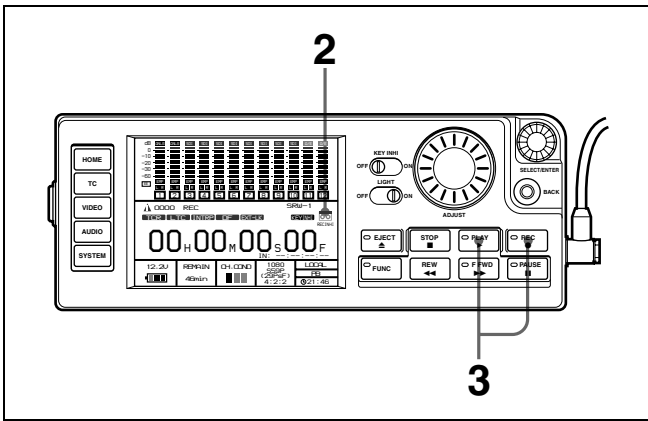

- 1 With the REC button held down, press the PLAY button to start recording.
- 2 Press the PAUSE button at the position where you want to pause.
- 3 To restart the recording, press the PAUSE button again.
- 4 Repeat steps 2 and 3.

- 1 Check that the record-protect plug on the cassette is in the position to enable recording.

For details, see 3-7-3 “Preventing Accidental Erasure” (page 39).

- 2 Check that the REC INHI indicator is not lit, then insert the cassette.

For details, see 3-7-2 “Inserting and Ejecting Cassettes” (page 38).

If the REC INHI indicator is lit

It indicates that the cassette is record-protected. Set the REC INHI item in the SYSTEM Setup menu (see page 52) to OFF.

- 3 With the REC button held down, press the PLAY button.

Recording starts, and REC LOCK appears when the servos lock.

Press the STOP button to stop recording.

Sequential Recording

The system is capable of frame-accurate sequential recording, which allows you to maintain continuity in the recording across pause points.

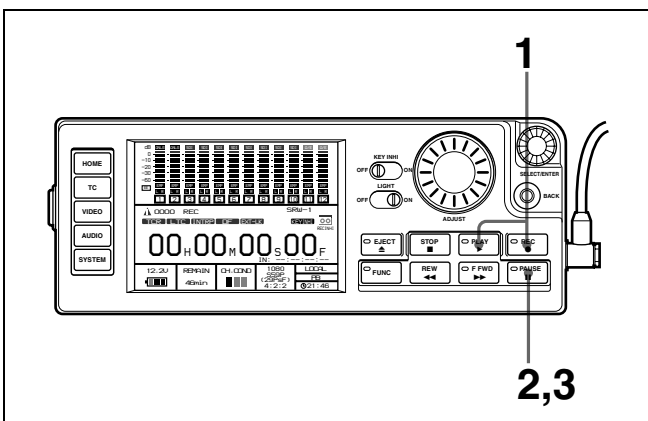

5-3 Playback Preparations and Operations

This section describes preparations for playback.

About connections for playback, see page 29.

5-3-1 Selecting the Conversion Mode of the Downconverter

The following three modes are available for the internal HD-SD downconverter.

- **Letterbox mode**

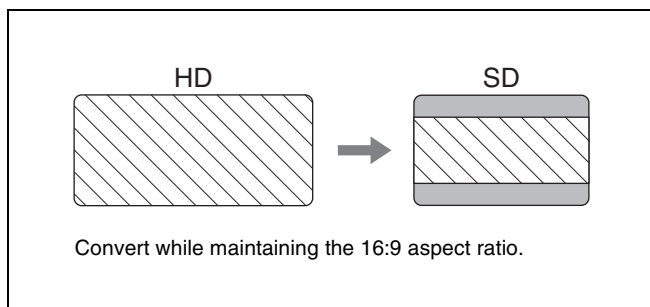

- **Edge crop mode**

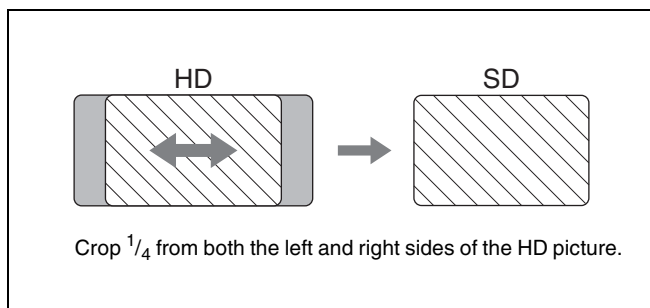

- **Squeeze mode**

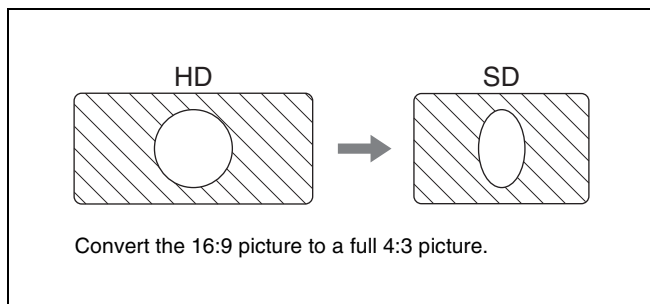

To select the conversion mode

In the VIDEO Setup menu (see page 47), set DC >TYPE to one of the following.

LB: Letterbox mode

EC: Edge crop mode

When this is selected, you can use DC > POS(EC) to adjust the H crop (horizontal position of the cropped sections).

SQ: Squeeze mode

5-3-2 Making Audio Monitor Signal Settings

The AUDIO Setup menu (see page 48) allows you to make various settings related to audio monitor signals for playback.

The procedures are basically the same as those for making settings related to audio monitor signals for recording.

To adjust the level of audio output to the EARPHONES jack

Rotate the LEVEL knob.

5-3-3 Adjusting Playback Audio Levels

The PB LEVEL item in the AUDIO Setup menu (see page 48) allows you to adjust audio levels separately for each channel.

Note

Playback audio levels cannot be adjusted during recording.

The PB LEVEL settings window appears when you select the PB LEVEL item. The subsequent procedure is the same as steps 1 to 5 in “To set recording audio levels” (page 60).

To set the display range of the audio level meters

See page 60.

5-3-4 Selecting Time Data to Display During Playback

Proceed as follows to select the type of time data to display during playback.

- 1 Display the TC Setup menu. (See “To display the TC Setup menu” (page 61).)
- 2 Select TIMER SEL.

The TIMER SEL settings window appears. (See “To select the type of time data to display” (page 61).)

- 3 Rotate the SELECT/ENTER dial to select CTL, TC (timecode), or UBIT (user bits).

CTL: Display CTL signals recorded on the tape.

TC: Display TC or VITC read by the internal timecode reader.

The TCR SEL item in the TC Setup menu allows you to determine whether the timecode reader is to read LTC or VITC.

UBIT: Display user bit values inserted into the playback timecode.

- 4 Press the SELECT/ENTER dial.

5-3-5 Playback Operations

Proceed as follows.

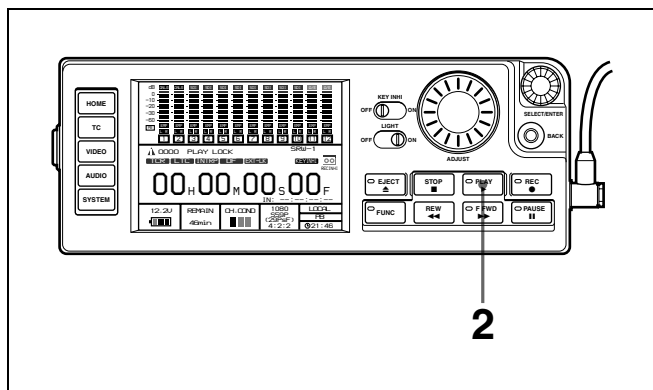

- 1 Insert the cassette to play back.

For details, “To insert cassettes” (page 38).

- 2 Press the PLAY button.

Playback starts, and PLAY LOCK appears when the servos lock.

Press the STOP button to stop playback.

To play back with tracking control

- 1 Insert the cassette to play back and press the PLAY button.
- 2 In the SYSTEM Setup menu select SERVO >TRACKING, and press the SELECT/ENTER dial.

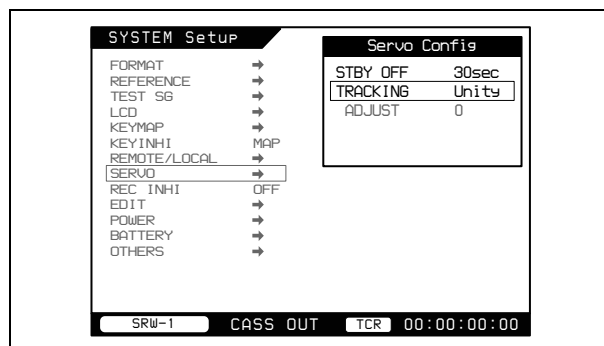

A setting window opens.

- 3 Rotate the SELECT/ENTER dial to select “VARI”, and press the dial.

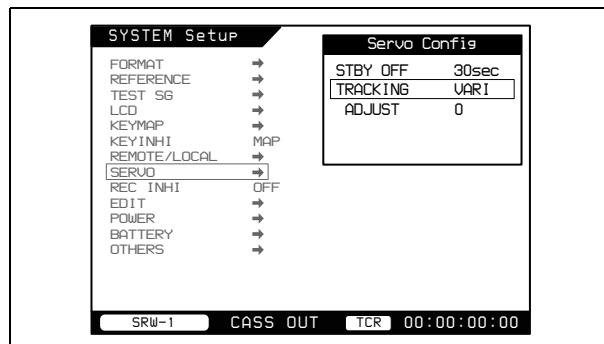

The “CH.COND” indication in the HOME screen flashes in yellow.

- 4 Select ADJUST and press the SELECT/ENTER dial.

The Tracking Adjust window appears.

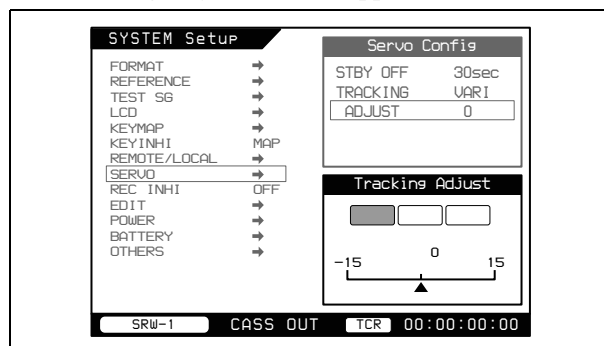

- 5 While viewing the channel condition display, rotate the ADJUST knob or SELECT/ENTER dial to adjust so that the channel condition display lights in green.

To release tracking control

Eject the cassette, or power the system off.

The setting of SERVO >TRACKING in the SYSTEM Setup menu returns to “Unity”.

5-4 SELECT FPS

Function (Selectable Recording Frame Rate) (When Optional HKSR-102 Is Installed)

5-4-1 Overview

SELECT FPS is a function that allows you to achieve a quick or slow motion effect during playback by shooting at a selected frame rate (Selectable Recording Frame Rate). The frame rate can be set across the following ranges, in units of 1 fps.

4:2:2 system: 1 to 60 fps

4:4:4 system: 1 to 30 fps

Refer to the HKSR-102 Installation Manual when installing the HKSR-102.

Setting the target frequency (system frequency during playback) and frame rate

To use the SELECT FPS function to achieve the desired slow or quick motion effect, you must set the frame rate to an appropriate value versus the target frequency. To achieve quick motion, shoot with undercrank (lower frame rate than the system frequency). To achieve slow motion, shoot with overcrank (higher frame rate than the system frequency).

Example: when the playback frequency is 23.98PsF (4:2:2 format)

To achieve a quick motion effect: Set the frame rate to 1 to 23 fps.

To achieve a slow motion effect: Set the frame rate to 25 to 60 fps. For example, shooting at 48 fps gives 1/2 speed slow motion.

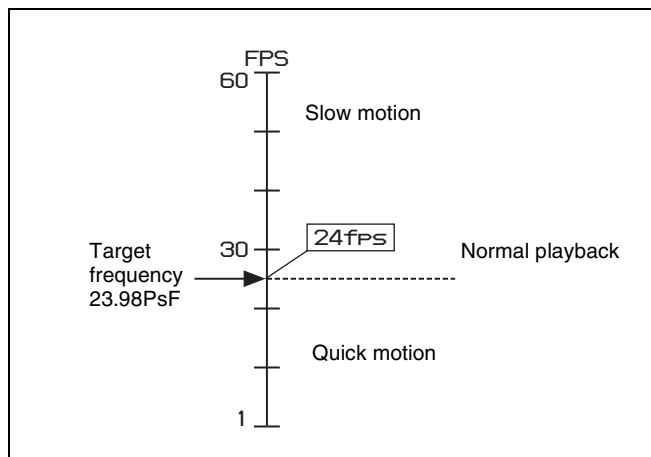

How this unit records during SELECT FPS shooting

During SELECT FPS shooting, recording data is first stored in the memory of the HKSR-102. Recording to tape begins when the amount of data in memory exceeds a certain threshold. For this reason, the tape will be stopped for a certain time after you start shooting, and will start running when the transfer from memory begins. After a certain amount of data is transferred, the tape stops again. This process is repeated as more data is recorded. You can check the amount of data stored in the memory of the HKSR-102 by checking the value and progress bar shown after “MEM:” at the bottom of the control panel display.

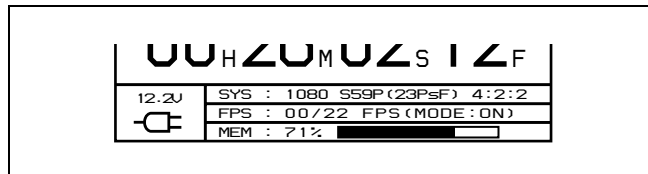

Notes

- During SELECT FPS recording, data transfer to the tape starts when the PAUSE or STOP button are pressed. The tally indicator on the front panel of the unit flashes at a rate of 4 flashes per second during data transfer to the tape. Do not power off the SRW-1 until data transfer to the tape completes.
- Recording to the tape does not begin before the amount of data in memory exceeds a certain threshold.

5-4-2 Setting the SELECT FPS

To perform SELECT FPS recording with frame rate (FPS) set on camera, use the following procedure to select a format and enable the SELECT FPS function.

- 1 Carry out steps 1 and 2 of the procedure in “To set with *FORMAT*” (page 55) in 5-1-1 “Selecting the System Signal Format”.
- 2 Refer to steps 3 to 5 of the procedure in “To set with *FORMAT*” (page 55) in 5-1-1 “Selecting the System Signal Format” to set the target frequency (FRAME) and signal format (SIGNAL).

You can also use *Others* to display the format list and select the format. For details, see “To set with *OTHERS*” in 5-1-1 “Selecting the System Signal Format” (page 55).

- 3 Set FPS FORMAT in the same way.

The selectable FPS *FORMAT* settings vary depending on the combination of target frequency and signal format selected in step 2.

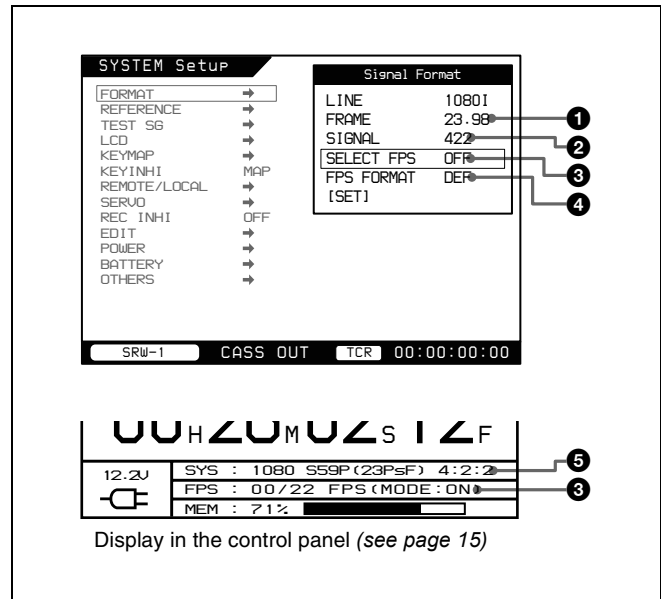

Menu settings				State of the SRW-1			
Format		④ FPS FORMAT	③ SELECT FPS	System frame frequency (Hz)	⑤ Format display	Reference signal frame frequency (Hz)	SD monitor output
② SIGNAL	① FRAME (target frequency, Hz)						
4:2:2	23.98	DEF or 59/60	Set ON →	59.94	1080 S59P (23PsF) 4:2:2	29.97	525/59.94i
	24	50		50	1080 S50P (24PsF) 4:2:2	25	625/50i
		DEF or 59/60		60	1080 S60P (24PsF) 4:2:2	30	No output
	25	DEF or 50		50	1080 S50P (25PsF) 4:2:2	25	625/50i
		59/60		60	1080 S60P (25PsF) 4:2:2	30	No output
29.97	DEF or 59/60	59.94		1080 S59P (29PsF) 4:2:2	29.97	525/59.94i	
4:4:4 SQ 4:4:4 HQ	23.98	DEF or 29/30		29.97	1080 S29PsF (23PsF) 4:4:4 SQ (or HQ)	29.97	525/59.94i
	24	25		25	1080 S25PsF (24PsF) 4:4:4 SQ (or HQ)	25	625/50i
		DEF or 29/30		30	1080 S30PsF (24PsF) 4:4:4 SQ (or HQ)	30	No output
	25	DEF or 50		25	1080 S25PsF (25PsF) 4:4:4 SQ (or HQ)	25	625/50i
		29/30	30	1080 S25PsF (25PsF) 4:4:4 SQ (or HQ)	30	No output	
29.97	DEF or 29/30	29.97	1080 S29PsF (29PsF) 4:4:4 SQ (or HQ)	29.97	525/59.94i		

Example settings

In the case

- Signal format: 4:2:2
 - Target frequency: 24 Hz
- 50 or 59/60 can be selected for FPS *FORMAT*.
- When 50 is selected

The system frame frequency is set to 50 Hz. Supply a 25 Hz reference signal. The SD monitor output is 625/50i. However, the frame rate is up to 50 fps.

- When 59/60 is selected
- The system frame frequency is set to 60 Hz. Supply a 30 Hz reference signal. The frame rate can be set up to 60 fps, which is an effective way to further enhance a slow motion effect. However, SD monitor output is disabled.

- 4 In the submenu window, select [SET].

Note

[SET] is disabled (displayed in gray) when the FPS FORMAT setting is invalid. Return to step 3 to change the setting.

- 5 Make sure of the settings, and then select [OK].
- 6 Rotate the SELECT/ENTER dial to select SELECT FPS in the submenu window.

A settings window appears.

- 7 Rotate the SELECT/ENTER dial to select ON, and then press the dial.

When SELECT FPS is set to ON, the camera connected to the SRW-1 must support the SELECT FPS function. By enabling the SELECT FPS function on both this unit and the camera, you can obtain smooth slow motion and quick motion effects.

When SELECT FPS is set to VTR, the camera connected to the SRW-1 does not need to support the SELECT FPS function. Input a signal that matches the system format shown in the format display. This unit extracts and recording frames as required from the input signal, according to the selected number of frames.

To dub a tape shot with SELECT FPS using two SRW-1 units

Select DUB in step 7.

Note

When the HKSR-102 is not installed, setting SELECT FPS to ON has the same effect as setting it to DUB.

To set the frame rate (FPS) on the SRW-1

- 1 Select VTR in step 7.
- 2 Return to the HOME screen, and press the SELECT/ENTER dial with the FUNC button held down.

The current frame rate (FPS) appears in a popup window.

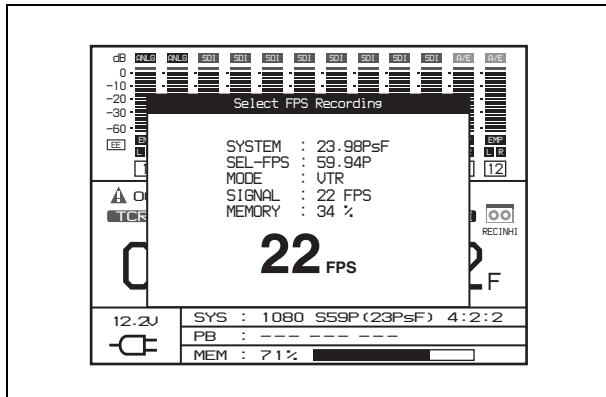

- 3 Rotate the SELECT/ENTER dial to change the frame rate.

Appendixes

Maintenance and Inspections

Head Cleaning

Use the BCT-HD12CL Cleaning Cassette to clean the video and audio heads. Read the instructions included with the cleaning cassette carefully, as improper usage can damage the heads.

When you insert the cleaning cassette, it is automatically ejected after a cleaning operation which lasts for about five seconds.

Note

Do not run the cleaning tape more than six times in succession to avoid damaging the heads.

Refer to the instructions of the cleaning cassette for detailed information about cleaning the video and audio heads.

Handling the Optical-Fiber Connector (When Optional HKSR-101 Is Installed)

Communications errors can occur if dust accumulates on the surface of the connector of the optical-fiber cable. Always clean the optical-fiber connector before use. Whenever the optical-fiber connector (CAMERA connector) is not in use, always cover it with the cap supplied with the HKSR-101 so that no dust accumulates.

Refer to the HKSR-101 Installation Manual for information about cleaning the optical-fiber connector.

Condensation

If you suddenly move the VTR (SRW-1) from a cold location to a warm one, or use the VTR in a very humid place, moisture in the air can collect on the head drum or tape guide. This is called condensation.

If you play a tape under these conditions, the tape may adhere to the drum where moisture has collected and become damaged. To prevent this, the SRW-1 has a condensation detection mechanism.

When condensation is detected

If the condensation detection mechanism detects condensation on the head drum during use, a popup window appears in the display of the control panel, displaying the message “VTR: 007F HUMID ERROR” (see page 72).

See the figure under “About Error Messages”(page 72) for more information about this and other error messages.

When condensation is detected, the VTR enters tape protection mode (see page 73).

If “VTR: 007F HUMID ERROR” appears immediately after you power the system on

Leave the system powered on, and wait for the message to disappear. Cassettes cannot be inserted while the message is visible.

When you suddenly move the VTR from a cold location to a warm one

Leave the VTR powered off for about 10 minutes, since some time is needed for the condensation detection mechanism to work.

Specifications

General

Power requirements

12 V DC +5.0/-1.0 V
(The power for SRW-1 is supplied via SRPC-1.)

Power consumption

SRW-1 Approx. 60 W
SRPC-1 Approx. 35 W

Operating temperature

0°C to 40°C (32°F to 104°F)

Storage temperature

-20°C to +60°C (-4°F to +140°F)

Operating relative humidity

25% to 80%

Mass

SRW-1 5.9 kg (13 lb)
SRPC-1 3.0 kg (6 lb 9 oz)

External dimensions (w/h/d, excluding projections)

SRW-1 283 × 206 × 139 mm (11 1/4 × 8 1/8
 × 5 1/2 inches)

SRPC-1 266 × 193 × 139 mm (10 1/2 × 7 5/8
 × 5 1/2 inches)

When SRW-1 and SRPC-1 are joined
283 × 399 × 139 mm (11 1/4 × 15 3/4
 × 5 1/2 inches)

Recording format

HDCAM-SR

Tape speed (normal speed)

94.1 mm/s (with the frame frequency of
24 Hz)

98.1 mm/s (with the frame frequency of
25 Hz)

117.6 mm/s (with the frame frequency of
30 Hz)

Recording/playback time

At normal speed

Maximum 50 minutes (with BCT-40SR
cassette, in 24P mode)

At double speed

Maximum 25 minutes (with BCT-40SR
cassette, in 24P mode)

Fast forward/rewind time

5 minutes or less

Fast forward/rewind speed

Maximum 11 times normal playback
speed

Search speed

Maximum 11 times normal playback
speed

Usable cassette

HDCAM-SR cassette (S-size)

Digital Video System

Sampling frequency

Y: 74.25 MHz, Cb/Cr: 37.125 MHz
R/G/B: 74.25 MHz

Quantization 10 bits/sample

Compression MPEG-4 Studio Profile

Channel coding

S-NRZ

Error correction

Reed-Solomon code

Error concealment

Adaptive three dimensional

Digital Audio System

Digital audio signal format (channels 1 to 12)

Sampling frequency

48 kHz (synchronized with video)

Quantization 24 bits/sample

Wow and flutter

Below measurable level

Headroom

20 dB

Analog output

D/A quantization

24 bits/sample

Frequency response

20 Hz to 20 kHz +0.5dB/-1.0 dB (at
reference level)

Dynamic range

More than 100 dB (at 1 kHz)

Distortion

Less than 0.05% (at 1 kHz, reference
level)

Crosstalk

Less than -80 dB (at 1 kHz, between any
two channels)

Input Connectors

SRW-1

AUDIO INPUT CH-1, CH-2

XLR 3-pin (×2), female
Switchable between -44 dB and +4 dB,
high impedance, balanced

TC IN

BNC type (×1)
0.5 to 18 Vp-p, 10 kΩ

SRPC-1

HD SDI IN A, B

BNC type (×2)
HD Serial Digital Interface signal
(1.485 Gbps), conforming to SMPTE
292M / SMPTE 372M / BTA S004 /
ITU-R.BT709

REF IN HD, SD	BNC type (×2) HD: Tri-level sync, 0.6 Vp-p, 75 Ω, sync negative SD: Black burst, 0.286 Vp-p, 75 Ω, sync negative
AES/EBU INPUT CH7/8, CH9/10	BNC type (×2) AES/EBU format, unbalanced
AUDIO INPUT CH3, CH4	XLR 3-pin (×2), female Switchable between -44 dB and +4 dB, high impedance, balanced
DC IN	XLR 4-pin (×1), male

Output Connectors

SRW-1

EARPHONES	Stereo minijack (×1)
TC OUT	BNC type (×1) 1.0 Vp-p (75 Ω), 2.2 Vp-p (10 kΩ)

SRPC-1

HD SDI OUT A, B	BNC type (×2) HD Serial Digital Interface signal (1.485 Gbps), conforming to SMPTE 292M / SMPTE 372M / BTA S004 / ITU-R.BT709
MONITOR OUT HD SDI, SD SDI	BNC type (×2) HD: HD Serial Digital Interface signal (1.485 Gbps), character superimposition possible, conforming to SMPTE 292M / SMPTE 372M / BTA S004 / ITU-R.BT709 SD: D1 Serial Digital Interface signal (270 Mbps), character superimposition possible, conforming to SMPTE 259M
AES/EBU OUTPUT (CH 1-12)	D-sub 15-pin (×1) AES/EBU format, unbalanced
MONITOR OUTPUT L, R	XLR 3-pin (×2), male +4 dBu (600 Ω), low impedance, balanced
EARPHONES	Stereo minijack (×1)

Other Connectors

SRW-1

CTRL PANEL	Control panel connector
------------	-------------------------

SRPC-1

CAMERA (when optional HKSR-101 installed)	Optical-fiber connector (×1) HD Serial Digital Interface signal
---	--

Supplied Accessories

SRW-1

Control panel extension cable	(1)
Shoulder belt	(1)
Assist lever holding bracket	(1)
Cable clamp	(1)
Operation Manual	(1)

SRPC-1

Splash guard caps	(1 set)
Operation Guide	(1)

Optional Accessories

AC-DN10/DN2B AC Adaptor
BP-GL95 Battery Pack
BC-M150/M50 Battery Charger
BCT-6/33/40SR HDCAM-SR videocassette tape
BCT-HD12CL Cleaning Cassette
HKSR-101 Optical Interface Unit
FC2-PD50/PD250 Optical-Fiber Cable
RM-B750/B150 Remote Control Unit
HKSR-102 Picture Cache Board
RCC-5G 9-pin Remote Control Cable

Connectors for optical/electric composite cables:

- LEMO (R) PUW.3K.93C.TLCC96 (to the “CAMERA” connector on VCR)
- LEMO (R) FUW.3K.93C.TLMC96 (to the “VCR” connector on CAMERA)

Caution on the optical/electric composite cable:

For connection between the videocassette recorder and a camera, be sure to use an optical/electric signal composite cable with the connectors specified in this manual in order to comply with the limit for EMC regulations.

Connecteurs pour les câbles optiques/électriques composites:

- LEMO (R) PUW.3K.93C.TLCC96 (au connecteur « CAMERA » du magnétoscope)
- LEMO (R) FUW.3K.93C.TLMC96 (au connecteur « VCR » de la caméra)

Précaution concernant le câble optique/électrique composite:

Pour la connexion entre le magnétoscope et une caméra, utilisez un câble optique/électrique composite avec

connecteurs spécifiés dans ce manuel pour assurer la conformité avec la réglementation EMC.

Anschlüsse für optische/elektrische FBAS-Kabel:

- LEMO (R) PUW.3K.93C.TLCC96
(an „CAMERA“-Anschluss am Videorecorder)
- LEMO (R) FUW.3K.93C.TLMC96
(an „VCR“-Anschluss an der KAMERA)

Vorsichtsmaßnahmen für optische/elektrische FBAS-Kabel:

Für Verbindung zwischen Videorecorder und Kamera verwenden Sie immer ein optisches/elektrisches FBAS-Kabel mit Steckern, wie in dieser Anleitung beschrieben, um die Grenzwerte der geltenden EMV-Vorschriften zu erfüllen.

Recommended Accessories

AES/EBU digital audio signal output cable (D-sub 15-pin)

For more information about recommended accessories, contact your Sony service representative.

For information about recommended cameras for SELECT FPS recording, contact your Sony service representative .

Design and specifications are subject to change without notice.

Error Messages and Warning Messages

About Error Messages

When the system stops operating incorrectly because of an internal error, a warning tone sounds and a popup window appears in the display of the control panel with an error message.

Only one message is displayed at one time, even if multiple errors occur. But the number of current errors appears at the bottom of the popup window.

Example:

Popup window displaying error message “VTR: 007F HUMID ERROR” (condensation detected)

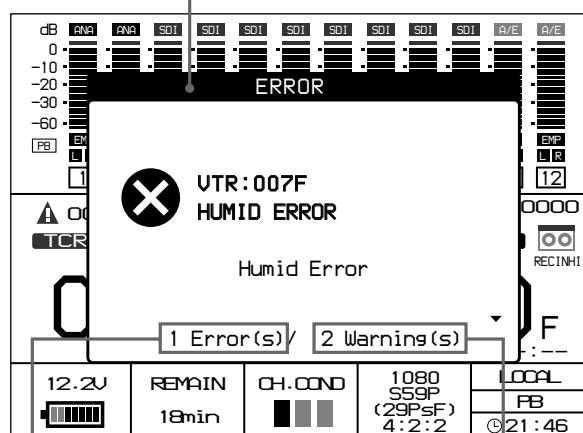

There is one current error.

There are two current warnings (see page 75).

To view the other messages, rotate the SELECT/ENTER dial on the control panel.

When an error message appears

Eliminate the cause of the error, and power the system off and on again. If the same error message appears again when the system is powered on, contact your Sony service representative.

To close the error message popup window

Press the HOME button or the BACK button on the control panel.

If you press the HOME button, an error code appears in the operation status and warnings section of the control panel display (see page 15).

If you press the **BACK** button, the same error code appears in the operation status and warnings section of the display when you move back as far as the **HOME** screen.

The error code remains visible until the cause of the error is eliminated.

Tape protection mode

To protect the tape and the mechanical parts of the SRW-1, the servo control system automatically stops tape transport and the drum motor and enters tape protection mode when an error occurs.

Cassettes may not be inserted or ejected while the SRW-1 is in tape protection mode.

Note

If a cassette is stuck in the SRW-1 because of tape protection mode, remove the tape manually, making sure to power the system off before doing so.

See “To remove a cassette with the system powered off” (page 39) for more information about how to remove a cassette manually.



Error messages

Refer to the Maintenance Manual for more detailed information about the content of error messages, and about errors not listed here.

Code		Message	Description
SRW-1 error ^{a)}	SRPC-1 error ^{b)}		
0010	0110	FAN STOP	A cooling fan stopped.
0011	0111		
0012	—		
0014	0114	DC VOLTAGE DOWN	Decline in DC voltage was detected.
—	0115	BATT TEMPERATURE NG	Abnormal battery temperature was detected. (Exchange the battery.)
0050	—	NO REC RF	Recording error occurred. Could not detect RF signal.
0057	—	EQ NVRAM SUM ERROR	EQ NVRAM operating error was detected.
005F	—	EQ TEMP NG	Abnormal EQ temperature was detected.
0060	—	SLACK-10	Drum drive voltage error was detected.
0061	—	SLACK-11	Drum FG error was detected.
0062	—	SLACK-12	Drum PG error was detected.
0065	—	SLACK-75	It is necessary to check the cassette.
0066	—	SLACK-70	Servo NVRAM communications error was detected.
0067	—	SLACK-71	System control initialization command error was detected.
0068	—	SLACK-20	Capstan drive voltage error was detected.
0069	—	SLACK-21	Capstan FG error was detected.
006B	—	SLACK-23	Capstan rotation direction error was detected.
006C	—	SLACK-24	Capstan speed error was detected.
0071	—	SLACK-61	Function cam forward rotation time-out error was detected.
0072	—	SLACK-62	Function cam reverse rotation time-out error was detected.
0073	—	SLACK-63	Tape top detection time-out error was detected.
0074	—	SLACK-64	Full top detection time-out error was detected.
0075	—	SLACK-65	Tape end detection time-out error was detected.
0076	—	SLACK-66	Cassette ejection error was detected.
0077	—	F-TOP SENSOR ERR	FULL TOP sensor error was detected. (Exchange the sensor.)
0078	—	SLACK-32	S-reel FG error was detected.
0079	—	SLACK-42	T-reel FG error was detected.
007A	—	SLACK-33	S-reel direction error was detected.
007C	—	SLACK-34	S-reel speed error was detected.
007D	—	SLACK-44	T-reel speed error was detected.
007F	—	HUMID ERROR	Condensation detector detected condensation.

a) When an SRW-1 error is detected, the error code is displayed following the indication “VTR:”.

b) When an SRPC-1 error is detected, the error code is displayed following the indication “VA:”.

About Warning Messages

If one of the conditions described in the table of warning messages (*see page 76*) is detected, a warning message code appears in the operation status and warnings section of the control panel display (*see page 15*). This section is visible when the display is showing the HOME screen.

Note

Warning messages do not appear unless the display is showing the HOME screen. To display the HOME screen, press the HOME button on the control panel.

To check the content of warning messages

Press the SELECT/ENTER dial on the control panel. A popup window appears to display messages for the current warnings.

Only one message is displayed at one time, even if multiple warnings occur. But the number of current warnings appears at the bottom of the popup window.

Example:

Popup window displaying warning message "VTR: 0010 TELEFILE FULL"

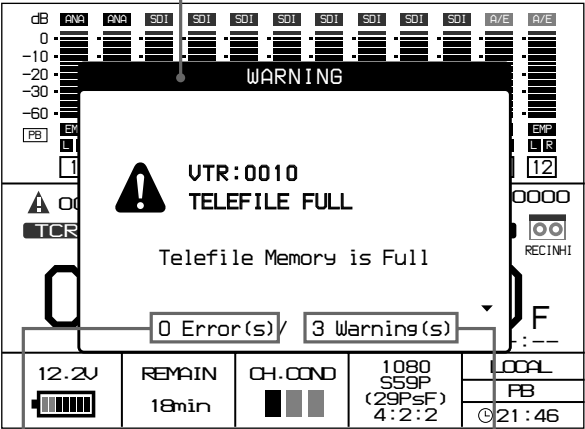

There is no current error (*see page 72*).

There are three current warnings.

To view the other messages, rotate the SELECT/ENTER dial on the control panel.

When a warning message appears

Take any action that may be needed to eliminate the cause of the warning.

Warning messages

Code		Message	Description
SRW-1 warning ^{a)}	SRPC-1 warning ^{b)}		
0001	—	PB FREQ MISMATCH	System frequency of this system does not match system frequency on the tape.
0004	—	NO PB LTC	Playback LTC cannot be detected.
0005	—	NO PB VITC	Playback VITC cannot be detected.
0007	—	REC INHIBIT MODE	The system cannot record because of a record inhibit menu setting. Or the tape is not formatted for recording.
0008	—	INVALID FMT CONV	Format conversion is not possible with the current settings.
000C	010C	DC VOLTAGE LOW	DC voltage has fallen below the specified level.
000E	010E	TEMPERATURE HIGH	The temperature inside the unit has risen.
000F	—	VA MISSING	SRPC-1 is not connected.
—	010F	VTR MISSING	SRW-1 is not connected.
0010	—	TELEFILE FULL	Telefile memory is almost full. The next recording will erase existing data, beginning with oldest.
0011	—	TELEFILE NO ROOM	Free memory in a Telefile has been completely exhausted.
0013	—	TELEFILE FMT NG	Telefile format is invalid in 1 or more locations.
0014	—	TELEFILE RD FAIL	Telefile read failure occurred.
0015	—	TELEFILE WR FAIL	Telefile write failure occurred.
0016	—	TELEFILE WR INHI	Attempt to record was made when entire Telefile is write inhibited.
0017	—	NO TELEFILE LABE	Telefile could not be recognized.
—	0121	PD PLL UNLOCK	The pull-down PLL could not be locked on the selected reference signal. Input a correct reference signal. Pull-down output is not supported for the 24PsF format. In this case, set REFERENCE >MODE in the SYSTEM Setup menu to "Input", or after setting it to "EXT" set REFERENCE >EXTERNAL to "HD".
0022	0122	AUDIO PLL UNLOCK	Audio clock generator PLL is not locked to reference video signal.
—	0124	NO HD REF	No HD reference signal is being input, even though REFERENCE >EXTERNAL in the SYSTEM Setup menu is set to HD or HD&SD.
—	0125	NO SD REF	No SD reference signal is being input, even though REFERENCE >EXTERNAL in the SYSTEM Setup menu is set to HD&SD or SD.
—	0126	HD&SD REF ASYNC	HD reference signal and SD reference signal are not synchronized, even though REFERENCE >EXTERNAL in the SYSTEM Setup menu is set to HD&SD.
—	0128	REF SEL NOT GOOD	Reference signal selection is invalid.
—	012C	BAD HD REF	HD reference signal is invalid.
—	012D	BAD SD REF	SD reference signal is invalid.
0030	0130	NO SDI INPUT	When the optional HKSR-101 is installed, there is no valid input to the selected VIDEO I/O connector.
0032	0132	INVALID SDI DATA	SDI input signal data is invalid.
0034	0134	SDI A-B PHASE NG	Signals input to HD SDI IN A and B connectors are out of phase.

Code		Message	Description
SRW-1 warning ^{a)}	SRPC-1 warning ^{b)}		
0036	0136	SDI FMT MISMATCH	Format of signals input to HD SDI IN A and B connectors does not match system setting.
0037	0137	SDI I/P MISMATCH	I/P of signals input to HD SDI IN A and B connectors does not match system setting.
—	0138	NO EXT SDI INPUT	There is no HD SDI input signal, or the correct signal is not being input.
—	013A	INVALID SDI DATA	EXT SDI input signal data is invalid.
—	013C	SDI A-B PHASE NG	During SDI DUAL input, the phase difference between SDI input A and B is outside the allowable range.
—	013E	SDI FMT MISMATCH	The format of the SDI input signal does not match the system setting.
—	013F	SDI I/P MISMATCH	The Interlaced/progressive format of the SDI input signal does not match the settings of this unit. Audio signal processing circuits are not active.
004F	014F	AUDIO DSP UNLOCK	Audio signal processing circuitry is not operating.
0050	—	NO PB RF	Playback head is not reading digital data from tape.
0051	—	BAD CH CONDITION	Playback signal quality is bad.
—	0156	OPM IN LEVEL LOW	When the optional HKSR-101 is installed, the optical signal level of the signal input to the CAMERA connector is low.
0060	—	LOST LOCK	Capstan servo lock lost during playback or recording. (This message remains even after servo lock is restored. You can erase it by pressing the PLAY button.)
0067	—	CASSETTE REC INHI	The cassette is record-protected.

a) When an SRW-1 warning occurs, the warning code is displayed following the indication "VTR:".

b) When an SRPC-1 warning occurs, the warning code is displayed following the indication "VA:".

Warning System

When an error is detected immediately after the system is powered on, or during operation, the control panel display and the tally indicator (*see page 11*) alert you to the error. In addition, warning and alarm tones are output from the EARPHONES jack.

Notes

- Warning tones are not output unless BEEP(PHONE) >WARN in the AUDIO Setup menu (*see page 49*) is set to HIGH or LOW.

- Alarm tones are not output unless BEEP(PHONE) >ALARM in the AUDIO Setup menu (*see page 49*) is set to HIGH or LOW.

The following table lists the types of warning and alarm tones, and the state of the tally indicator, for warnings, errors, and other conditions which require your attention, such as tape end, near tape end, battery exhausted, and battery almost exhausted, along with the steps to take when they occur.

Warning tones ●●●●●●●●●● : 1 beep/ second ●●●●●●●●●● : 4 beeps/ second ●●●●●●●●●● : Continuous tone	Alarm tones ●●●●●●●●●● : 1 beep/ second ●●●●●●●●●● : 4 beeps/ second ●●●●●●●●●● : Continuous tone	Tally indicator ☀ : 1 flash/second ☀☀☀☀ : 4 flashes/ second	Description	VTR (SRW-1) behavior	Steps to take
—	—	—	A warning message condition occurred. (Excepting “Servo lock lost during recording” described below.)	Continues operation.	Check the warning message, and resolve the condition, referring to the “Description” column in the table of “Warning messages” (<i>page 76</i>).
●●●●●●●●●● a)	—	☀☀☀☀ b)	Servo lock lost during recording.	Recording continues, but the results may be invalid.	Turn off the power and contact a Sony service representative.
●●●●●●●●●●	—	☀	An error occurred (Excepting “0050 NO REC RF”).	Continues operation or stops, depending on the type of error.	Check the warning message, and resolve the condition, referring to the “Description” column in the table of “Error messages” (<i>page 74</i>). Or contact a Sony service representative. If a slack error occurs, refer to the maintenance manual and remove the cassette, or contact a Sony service representative.
●●●●●●●●●● a)	—	☀☀☀☀ b)	“0050 NO REC RF” error occurred. RF signals cannot be detected. Video head clogging or failure in recording system.	Recording continues, but the results may be invalid.	Clean the video heads. If recording fails after head cleaning, turn off the power and contact a Sony service representative.

Warning tones ●●●●●●●● : 1 beep/ second ●●●●●●●●●● : 4 beeps/ second ●●●●●●●●●●●●●●●●●●●● : Continuous tone	Alarm tones ●●●●●●●● : 1 beep/ second ●●●●●●●●●● : 4 beeps/ second ●●●●●●●●●●●●●●●●●●●● : Continuous tone	Tally indicator ☀ : 1 flash/second ☀☀☀☀ : 4 flashes/ second	Description	VTR (SRW-1) behavior	Steps to take
—	●●●●●●●● a)	☀	Near tape end.	Operation continues.	Prepare an exchange cassette.
—	●●●●●●●●●●●●●●●●●●●●	☀☀	Tape end.	Recording, playback, and fast forward stop.	Exchange the cassette, or rewind the tape.
—	●●●●●●●● a)	☀	Battery is almost exhausted. ^{c)}	Operation continues.	Exchange the battery.
—	●●●●●●●●●●●●●●●●●●●●	☀☀	Battery is exhausted. ^{c)}	Operation stops.	Exchange the battery.

- a) Output only during recording.
- b) Flashes only during recording.
- c) You can use the battery level/external power display on the display screen to check the state of the battery. (See pages 15 and 35.)

Attaching the Shoulder Belt

Attach the supplied shoulder belt as shown in the figure below.

Note

If you fit the shoulder belt incorrectly, the unit may fall down and cause body injury. Follow the procedures described below to fit or remove the shoulder belt.

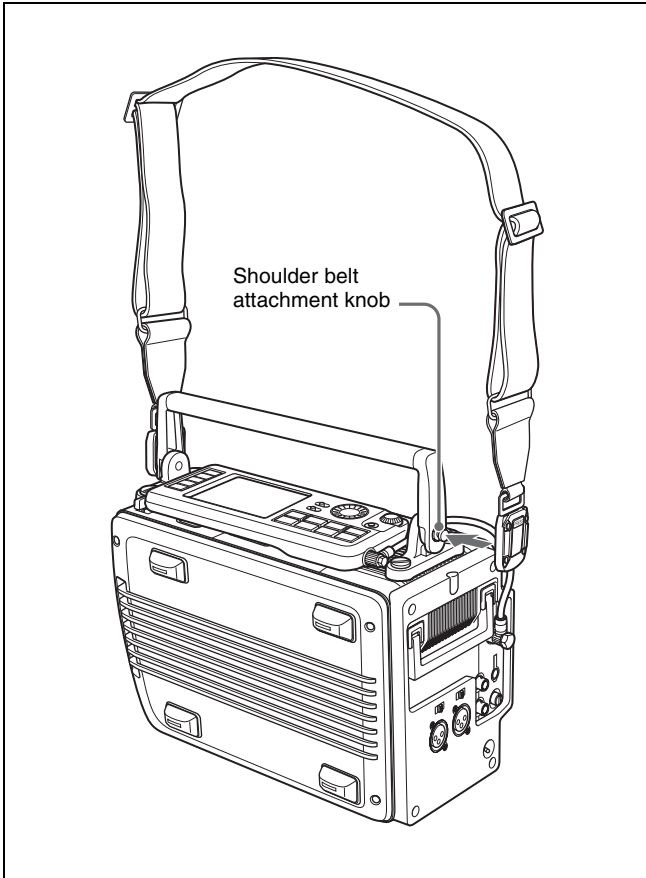

How to attach

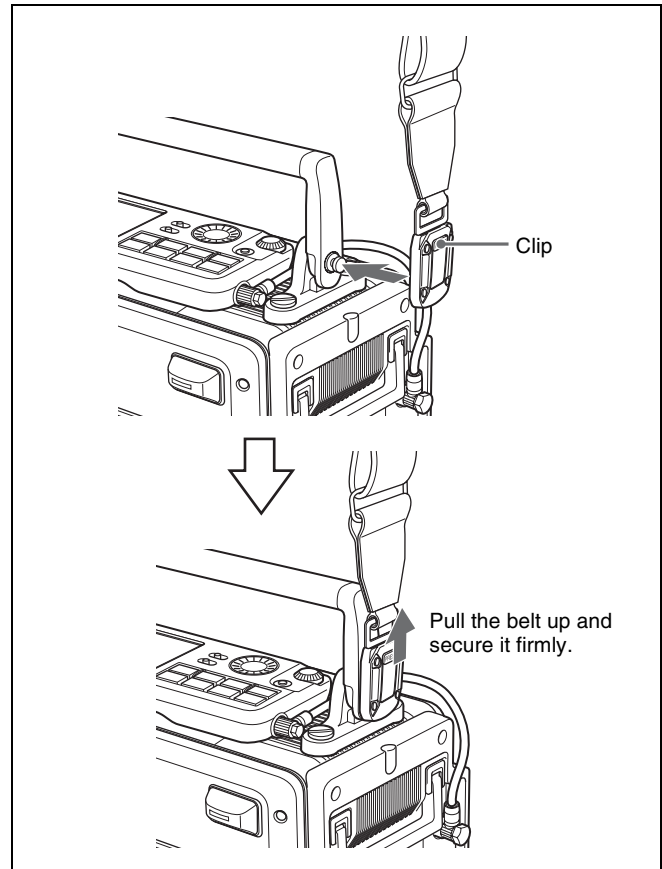

How to remove

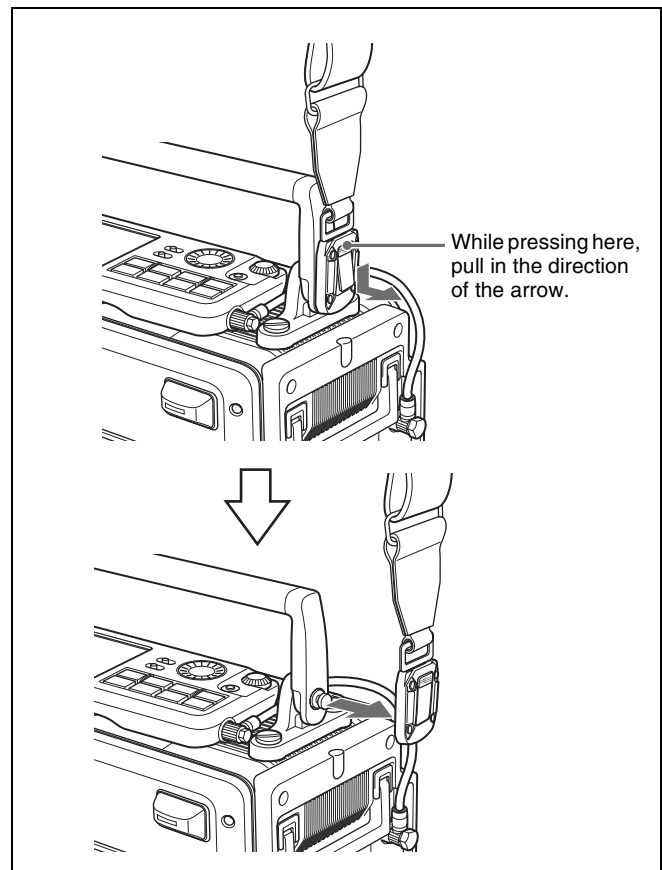

Troubleshooting

Video

Problem	Cause	Steps to take
Picture is gray. ^{a)}	No signal input to HD SDI IN A connector.	Input a signal in the selected system signal format to the HD SDI IN A connector.
	No signal input to HD SDI IN B connector (in 4:4:4 mode).	In 4:4:4 mode, input signals in the correct format to both the HD SDI IN A connector and the HD SDI IN B connector.
	The phase difference between the HD SDI IN A and HD SDI IN B signals is too large.	The phase difference may be too large, preventing proper reception, if one of the cables connected to the HD SDI IN A and HD SDI IN B connectors is much longer than the other. Connect cables of the same length to both connectors.
	The format of the signal input to one of the HD SDI IN A/B connectors is different from the system signal format.	The picture is gray when an input signal format is different from the system signal format. Input a signal in the correct format.
	Even though the setting of REFERENCE is EXT, the signal input to the REF IN connector is in the wrong format, or there is no input signal. When the setting of REFERENCE is EXT, input a reference signal in the selected system signal format to the REF IN connector.	When SD&HD is selected, and a proper HD signal is input, a picture appears even if the SD signal is missing or in the wrong format. When the SD is correct, a picture appears if the HD signal is missing, but the picture is gray if the HD signal is in the wrong format.
	The unit is playing back a section where nothing is recorded.	A gray picture appears when this unit is playing back a section where nothing is recorded on the tape.
	The heads are dirty.	The heads can become dirty when playing back a damaged section of a tape. Clean the heads.
	The input and reference signals are unstable.	The picture changes to gray when the input or reference signals are unstable or interrupted.
Picture color is wrong.	The SRW-1 is not powered on.	The system does not operate properly when the SRW-1 is not powered on, even if the SRPC-1 is powered on. Check the power switches. Check with the operation panel.
	In 4:4:4 mode, the HD SDI A and HD SDI B connections are switched.	Connect the proper signals to the HD SDI IN A and HD SDI IN B connectors.
	In 4:4:4 mode, two 4:2:2 pictures are being input to the HD SDI IN A and HD SDI IN B connectors.	Set the input device to 4:4:4.
	In 4:2:2 mode, a 4:4:4 picture is input.	Input 4:2:2 signals.
	In 4:4:4 mode, the signal from the VTR (HD SDI OUT B connector) is not being input to the monitor.	Even if there is no signal from the HD SDI OUT B connector, a picture appears on the monitor, which can make it difficult to detect connection mistakes. Input a signal from the HD SDI OUT B connector to the monitor.

Problem	Cause	Steps to take
<ul style="list-style-type: none"> Picture break-up. “AUDIO PLL LOCK” appears. 	The input signals are unstable.	Input the correct signals.
	The monitor does not support the format.	Some older monitors support only the 59.94/60 frequencies. Some of the newest monitors support the 720-50P format. Use a monitor with specifications supporting the format.
	The input signal does not agree with the system frequency.	Input a signal with 1.000/1.000 and 1.000/1.001 that agree with the system.
	The frequency exceeds the monitor scanning frequency.	If the monitor is a BVM-F24, 25PsF and 29.97PsF cannot be displayed with ×3 scanning, resulting in picture break-up. Use ×2 or ×1 scanning. For 59.94i and 50i, use ASD scanning.
<ul style="list-style-type: none"> Unnatural movement (ghosting). “PB FREQ MISMATCH” appears. 	Wrong interlace and PsF selection.	Set the input signal format so as to match the system signal format.
Movement stops, or is jerky.	Monitor is not operating properly.	Check the monitor settings. Try turning it off and on again.
<ul style="list-style-type: none"> Playback picture break-up. “PB FMT MISMATCH” appears. 	The recorded format (PB) does not match the playback format (SYS).	Put the display at the bottom right of the HOME screen into format display mode, and set the matched SYS and PB formats.
Want to show a test signal.	This can be done with menu settings.	Select CB or BLK under SYSTEM >TEST SG >VIDEO.
Test signal does not appear.	Test signals are turned off when the unit is powered off and on.	Select the test signal again.
SELECT FPS recording does not work.	The HKSR-102 board is not installed.	Install the optional HKSR-102 board to use the SELECT FPS function.
	The camera does not support the SELECT FPS function.	Select a camera that supports the SELECT FPS function before setting SELECT FPS to ON.
	The SRW-1 software does not support the SELECT FPS function.	Upgrade to a version that supports the SELECT FPS function. (Contact your Sony service representative.)
	The SELECT FPS function is not enabled on either the camera or the VTR.	Enable the SELECT FPS function on both the camera and the VTR.

a) At the same time, one of the following messages may appear.
 “NO PB RF”, “BAD CH CONDITION”, “AUDIO PLL UNLOCK”, “PD PLL UNLOCK”, “NO HD REF”, “NO SD REF”, “HD&SD REF ASYNC”, “REF SEL NOT GOOD”, “BAD HD REF”, “BAD SD REF”,

“INVALID SDI DATA”, “SDI A-B PHASE NG”, “SDI FMT MISMATCH”, “SDI I/P MISMATCH”, “NO EXT SDI INPUT”

Audio

Problem	Cause	Steps to take
<ul style="list-style-type: none"> No sound. AUDIO PLL UNLOCK appears. 	The display of the SDI or AES/EBU meter is flashing, and the input is invalid.	Set up the input device to output SDI or AES/EBU audio.
	Mode switching.	To prevent noise and damage to audio monitor equipment, audio is turned off when switching modes.
	Non Audio setting.	No audio is output when Non Audio mode is selected. A white box in the meter display indicates “Non Audio”.
	Volume is turned down.	When there is no sound from the headphones, even though the meters are moving, check to be sure that the volume is set to an appropriate level.
Cannot input AES/EBU.	AES/EBU is not locked to the video.	Lock the equipment on the AES/EBU input side to the video of the SRW-1.
	No 48kHz input.	Input 48kHz audio to the AES/EBU input.
	Not enabled.	Set up the input device to enable AES/EBU.

Problem	Cause	Steps to take
<ul style="list-style-type: none"> Noise. “PB FREQ MISMATCH” appears. 	Wrong sampling frequency.	Set the matched 1.000/1.000 and 1.000/1.001 formats.
	Playback at wrong frequency.	Noise occurs when the playback frequency is different from the recorded frequency, because of the difference in the number of audio samples. Switch the playback format to match the recorded frequency.
<ul style="list-style-type: none"> No audio input to SRPC-1 analog input. “NO EXT SDI INPUT” appears. 	No HD SDI signal input.	Input the correct HD SDI signal.
No analog audio input.	Electret condenser microphone is not powered on.	Set to +48V ON (except for internal battery powered types).
Want to output a test signal.	This can be done with menu settings.	Select 1kHz under SYSTEM >TEST SG > AUDIO.
Test signal is not output.	Test signals are turned off when the unit is powered off and on.	Select the test signal again.

Timecode

Problem	Cause	Steps to take
Character timecode values of video monitor output are wrong. (23.98 is set, but frames counted to 29, for example.)	Monitor output switch is set to AUTO (pulldown output).	By default the monitor output is set to AUTO (pulldown mode), so that character timecode is also displayed as pulldown timecode. To change this to actual line timecode display, set VIDEO >PD(MON) >OUTPUT to THRU.
<ul style="list-style-type: none"> Frequent timecode interpolation. “PB FREQ MISMATCH” appears. 	The tape playback section was recorded at a different frequency.	Interpolation is performed periodically for timecode recorded at a different frequency. The recorded frequency can be displayed as the PB format at the bottom of the control panel display by pressing the FUNC+HOME buttons.
Timecode is not consecutive.	<ul style="list-style-type: none"> During recording, a tape transport button other than PAUSE was pressed (e.g. STOP). The timecode settings are inappropriate. 	To record consecutive timecode after STOP is pressed, set TC >TCG MODE to RGN, and set TC >REGENE SOUCE to INT L. Then run the tape to position where the last recording stopped, press the FUNC+PLAY buttons, and perform an EOS search. To record consecutive timecode even after the PAUSE button is pressed to pause recording, set TC >TCG MODE to PRST, and set TC >RUN MODE to R RUN
	Timecode generation is set to free run.	When timecode generation is set to free run, a timecode break occurs with every recording. Set timecode generation to R RUN to have it start advancing at the start of recording.

Other

Problem	Cause	Steps to take
Power does not come on.	Insufficient battery output capacity.	Use AC-550/DN2B/DN10. Or connect a 150W or more power source with a short, thick cable.
	Under battery use, the EXT DC SELECT switch is set to the EXT side.	Set the switch to the AUTO side.
Power goes off.	The current limiter of your power source activated.	Adjust the limiter to take account of excess current when powering on and when switching modes.

Problem	Cause	Steps to take
Battery exhausted quickly.	Battery performance has degraded.	Exchange the battery.
	The battery type and voltage settings do not match.	Use SYSTEM >BATTERY to select the correct settings for the connector you are using, the battery type, and the “near end” and “end” voltages.
	Headphone volume or display brightness is higher than necessary.	Adjust the volume and display brightness.
	Unneeded equipment is connected.	Disconnect the unneeded equipment. You can also suppress the output of unneeded output signals. <i>For details, see POWER in the SYSTEM Setup menu (page 52).</i>
Cannot record.	The cassette is write inhibited.	Return the write inhibit plug to its original position.
<ul style="list-style-type: none"> • VTR does not power on. • “VTR MISSING”, “VA MISSING” appears. 	The VTR power switch is not on.	Turn the VTR power switch on.
	The SRW-1 and SRPC-1 are not completely connected.	Check the SRW-1 and SRPC-1 assembly.
Low voltage.	The power cable is too long, or low voltage supply is occurring.	Cable impedance can cause low voltage supply if the cable is too long or if it is a thin, low-capacity cable. Exchange the cable for a short, high-capacity cable.
Battery alarms appear frequently.	If battery alarms appear even when the input voltage is high enough, the DC “end” and “near end” voltage settings are wrong.	Use SYSTEM >BATTERY to select the appropriate voltages for the “end” and “near end” warnings, according to the DC input and battery type.

What Is Dual Link?

For HD SDI signal input/output, the SRW-1 supports Dual Link in addition to the normal Single Link.

The following lists the differences between Single Link and Dual Link, and explains what you can do with HD SDI signal input/output by them. Refer also to the table showing the available HD SDI formats with Single Link and Dual Link on the SRW-1.

Single Link

Single Link enables input and output of HD SDI signals over a single BNC cable.

With Single Link, you can do the following format selections.

- Handle basic 1080-line HD signals
The SRW-1 can handle 4:2:2 (Y/Cb/Cr)/1080/23.98PsF to 29.97PsF (59.94i) HD signals. HD signals are input from the HD SDI IN A connector. The HD SDI IN B connector is not used. The HD SDI OUT A and HD SDI OUT B connectors output the same signals. In power saving mode, signals are output from the HD SDI OUT A connector only. The number of pixels is 1920 × 1080.
- Handle 720P signals
In the 4:2:2 (Y/Cb/Cr)/720P format, you can handle the number of frames by using the 59.94P and 50P frequencies. When you do this, the number of pixels decreases to 1280 × 720.

Dual Link

Dual Link enables input and output of HD SDI signals over two BNC cables.

With Dual Link, you can do the following.

- Handle different color spaces
Dual Link allows you to expand color difference signals to RGB. The SRW-1 can handle 4:4:4(RGB)/1080/23.98PsF to 29.97PsF(59.94i) HD signals.
When you do this, all of the G component and half of the B and R components are input and output via the HD SDI IN/OUT A connector. The other half is input and output via the HD SDI IN/OUT B connector.
HD SDI IN/OUT A = G / 0.5 × B' / 0.5 × R'
HD SDI IN/OUT B = None / 0.5 × B'' / 0.5 × R''
- Increase the number of channels
Dual Link allows you to record and play back two 4:2:2 Single Link channels as DUAL STREAM on a single tape.
HD SDI IN/OUT A = Channel 1
HD SDI IN/OUT B = Channel 2
However, multiplexed audio and timecode is recorded by HD SDI IN A only.
- Increase the number of frames
Dual Link allows you to double the number of frames to 4:2:2 60P.
HD SDI IN/OUT A = Even lines / Odd lines (alternating on each frame)
HD SDI IN/OUT B = Odd lines / Even lines (alternating on each frame)

HD SDI formats supported by the SRW-1

		Single Link		Dual Link	
Format		4:2:2 YCbCr	4:2:2 YCbCr 720P	4:4:4 RGB	4:2:2 YCbCr 60P
Frame rate		30/1.001 PsF 25 PsF 24 PsF 24/1.001 PsF 60/1.001 i 50 i	60/1.001 P 50 P	30/1.001 PsF 25 PsF 24 PsF 24/1.001 PsF 60/1.001 i 50 i	60/1.001 P 50 P
Effective frame size		1920 × 1080	1280 × 720	1920 × 1080	1920 × 1080
HD SDI IN/OUT A	Y channel	Y	Y	G	Y
	C channel	CbCr	CbCr	0.5B/0.5R	CbCr
HD SDI IN/OUT B	Y channel			–	Y
	C channel			0.5B'/0.5R'	CbCr
SMPTE		292M	296M	372M	372M

Psf: Progressive Segmented Frames
i: Interlace
P: Progressive

Index

A

AC power 34
AC-550 34
AC-DN10/DN2B 34
ADJUST knob 13
AES/EBU INPUT CH7/8 and CH9/10
 connectors 20
AES/EBU OUTPUT CH1-12
 connector 20
Assembly 23
Assist lever 20
AUDIO button 12
AUDIO INPUT CH-1 and CH-2
 connectors 18
AUDIO INPUT CH-3 and CH-4
 connectors 19
Audio level meters 15
 display range 60
Audio monitor signals
 setting 64
AUDIO Setup menu 48
Audio signals
 mixing 59
 monitoring 59
 recording 59
 recording level 60

B

BACK button 13
Backlight 36
BATTERY 53
Battery attachment section 19
Battery level 16
Battery pack 34
 attaching 34
Battery voltage 37
BEEP(PHONE) 49
BP-GL95/IL75 34

C

Cable clamp 26
CAMERA connector 21
CAMERA REMOTE IN connector 20
Cassette insertion slot 12
Cassettes 38
 inserting and ejecting 38
 preventing accidental erasure 39
 usable cassettes 38
Channel coding 8
Channel condition indicator 16
CHAR(MON) 45

CHAR(SD) 46
Condensation 69
Connections 27
 for playback 29
 for recording 27
 optical-fiber cable 28
 reference signals 31
Connector panel 17
Control panel 12
Control panel connection cable 13
Control panel extension cable 25
CTRL PANEL connector 17

D

DC 47
DC IN connector 21
Detaching the SRW-1 from the SRPC-1 24
Display 15
Double-speed recording 7
Downconverter 64
Drop-frame mode 37
Dual Link 85
 connection 28
DUAL STREAM 28

E

EARPHONES jack
 on SRPC-1 20
 on SRW-1 17
ECC encoder 8
Edge crop mode 64
EJECT button 12, 14
Error messages
 display 37
 examples 74
 overview 72
EXT DC SELECT switch 20
External power supply voltage 16

F

FORMAT 50
FUNC button 14

H

HD monitor 29
 pulldown conversion 58
HD SDI IN A and B connectors 20
HD SDI OUT A and B connectors 20
HDCAM-SR format 8
HDC-F950 27
HDW-F900 27
Head cleaning 69
HOME button 12
HOURS METER 53

I

Input interface 7
INPUT SEL 48
Input selection switches 18, 19

J

Joining the SRW-1 and SRPC-1 23

K

KEY INHI 51
KEY INHI switch 13
KEYMAP 51

L

LCD 51
Letterbox mode 64
LEVEL knob
 on SRPC-1 20
 on SRW-1 17
LIGHT switch 13
Lock lever 19
Lock release button
 for battery pack 34
 for control panel 12

M

Maintenance and inspections 69
Menu selection buttons 12
Menus
 AUDIO Setup 48
 basic operations 41
 displaying 41
 SYSTEM Setup 50
 TC Setup 43
 VIDEO Setup 47
METER TYPE 48
MIX MODE 48
MONITOR OUT connectors 19
MONITOR OUT HD SDI and SD SDI
 connectors 20

N

Names and functions of parts
 SRPC-1 19
 SRW-1 11
Non-drop frame mode 37
NTSC monitor 29

O

Operating mode 37
Operation status and warnings 15
Optical-fiber cable connection 28
 reference signal 31

Optical-fiber connector 21
 handling 69
OTHERS(MAIN) 44
Output interface 7

P

PB LEVEL 48
PB/EE (POWER mode) 52
 display 15
PD TC 44
PD(MON) 47
PEAK HOLD 48
PHONE SEL 48
Playback audio levels
 adjusting 64
Playback operations 65
POWER ON/OFF switch
 on SRPC-1 20
 on SRW-1 18
Power saving mode 40
Power supply 34
Power, checking 35
Processor connector 12
Pull-down conversion 58

R

Real time 62
 display 15
REC INHI 52
REC LEVEL 48
Recorder connector 19
Recording operations 62
Recording video selection 58
REF IN HD and SD connectors 20
REFERENCE 50
Reference signals for video output
 signals 30
Reference sync signals 30
REGENE SOURCE 43
Release knob 19
Remaining battery power 35
Remaining tape time 16
REMOTE IN connector 20
REMOTE/LOCAL 51
 display 15
RF indicator 16
RUN MODE 43

S

Screen saver 36
SELECT FPS function 66
 display 16
SELECT/ENTER dial 13
Sequential recording 63
SERVO 52
Setting window 42

Shoulder belt 80
Side handle 12
Signal formats 16
 menu settings 50
 settings 55
Signal processing 8
SOFT VERSION 53
Specifications 70
Squeeze mode 64
Status 15
Submenu window 41
Superimposed text 36
 position 37
System configuration 10
SYSTEM Setup menu 50

T

Tally indicator 12
Tape protection mode 73
Tape remaining 16, 37
Tape transport control buttons 13
TC button 12
TC IN connector 17
TC OUT connector 17
TC Setup menu 43
TCG MODE 43
TCG SET(MAIN) 44
TCR SEL 43
TeleFile 57
TEST SG 51
Time data 15
 selecting the type 61
 selecting time data to display during
 playback 64
Timecode
 recording 61
 selecting timecode to record 61
Timecode generator 8
Timecode reader 8
TIMER PRESET 43
TIMER RESET 43
TIMER SEL 43
Top handle 12
Tracking control 65
Troubleshooting 81

U

User bits
 recording 62
 selecting 61

V

VIDEO button 12
Video monitor
 output signals 36, 56
VIDEO Setup menu 47

VITC data 37
Voltage, checking 35

W

Warning messages
 display 37
 examples 76
 overview 75
Warning system 78

The material contained in this manual consists of information that is the property of Sony Corporation and is intended solely for use by the purchasers of the equipment described in this manual.

Sony Corporation expressly prohibits the duplication of any portion of this manual or the use thereof for any purpose other than the operation or maintenance of the equipment described in this manual without the express written permission of Sony Corporation.

Sony Corporation

SRW-1
SRPC-1
(SY)
3-854-913-04 (1)

<http://www.sony.net/>



Printed on 100% recycled paper

Printed in Japan
2005.09.13
© 2004